

4 3 2 1

F

F

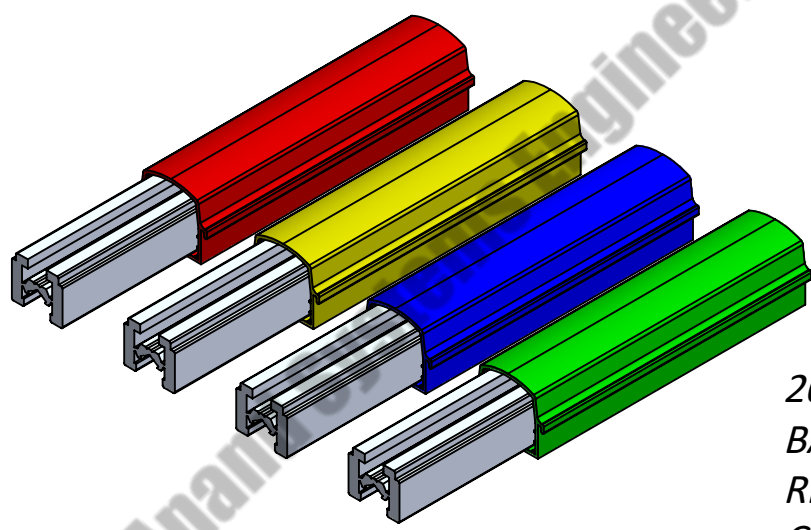
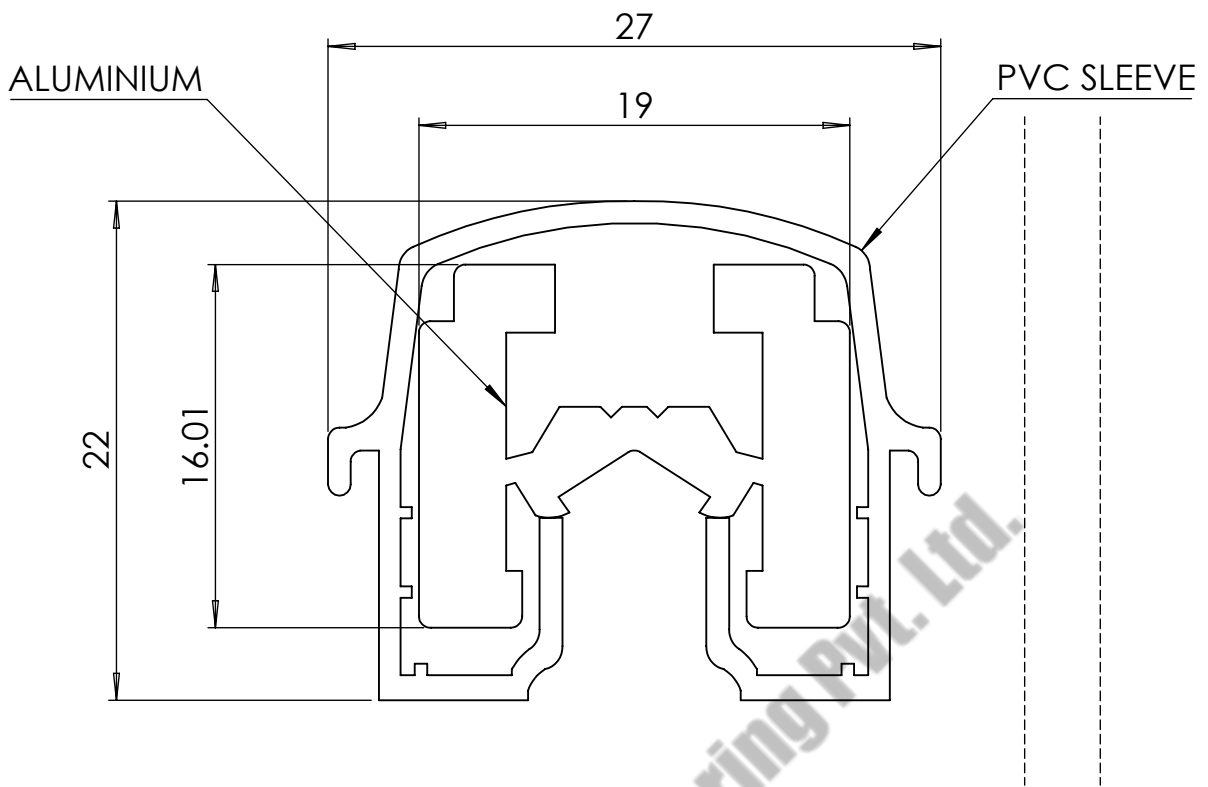

200AMP- ALUMINIUM- 04
 BAR BOLTED(W) TYPE
 RED YELLOW BLUE GREEN
 COLOUR PVC

D

D

C

C

B

B

COMPANY NAME:



ANAND SYSTEM
 ENGINEERING PVT LTD

DO NOT SCALE DRAWING.

REVISION:

TITLE:

Safelink W
 200Amp ALU
 RYBG 2D

Email id: info@anandcontrol.in

CONTACT NO: 9137620579

FINISH:

DWG NO.

DATE:

SIGNATURE:

A

A

DRAWN	SAURABH			MATERIAL:			
CHK'D							A
APP'D							
MFG				WEIGHT:		SCALE:	SHEET: 1 OF 1

4 3 2 1

ITEM NO.	PART NAME	DESCRIPTION	MATERIAL	QTY.
1	4 POLE HANGER CLAMP W TYPE.ASSEMBLY	158X29X20	DELTRIN	4
	4 POLE HANGER CLAMP CC	158X29X20	DELTRIN	1
	HEX BOLT	M8, 8X20, END COVER FIXING	M.S.	2
	PLAIN WASHER	19X8.5X1.5	M.S.	2
	HEX NUT	M6	M.S.	2
	SPRING WASHER	M8	SPRING STEEL 4454 GRADE-02	2
2	BUSBAR ASSEMBLY W TYPE	40X40X400, THK-5 MM		4
	AL-W-type	4500X19X16.5	ALUMINIUM	1
	SLEEVE W TYPE	4415X26X22	PVC	1
3	Web-Bracket W TYPE	35X35, THK-5 MM	M.S.	6
	JOINT CLAMP ASSEMBLY W TYPE	70X28X40	G.I	8
4	HEX NUT	M6	M.S.	4
	PLAIN WASHER	M8	M.S.	4
	POWERFEED CLAMP W-TYPE	16.3X22X81	ALUMINIUM	1
	SPRING WASHER M6 W TYPE	M6	SPRING STEEL 4454 GRADE-02	4
	SQUARE HEAD BOLT W- TYPE	18XM6	M.S.	4
	JOINT COVER W-TYPE	42X26X102	DELTRIN	8
5	ANCHOR CLAMP ASSEMBLY W TYPW	28X30X20	DELTRIN	4
	ANCHOR CLAMP W TYPE		DELTRIN	2
	HEX_BOLT	M8X25	M.S.	1
	HEX NUT	M8	M.S.	1
6	PLAIN WASHER	M8	M.S.	1
	SPRING WASHER	M8	SPRING STEEL 4454 GRADE-02	1
	HEX BOLT	M5X35	M.S.	1
	LOCK NUT	M5	M.S.	1
7	CENTER POWERFEED ASSEMBLY W-TYPE	219X105.6X37		4
	CENTER POWERFEED W-TYPE-1		DELTRIN	2
	NUT	M8	M.S.	2
	PAN HEADED SCREW	SELF THREAD SCREW	M.S.	3
	PAN HEADED SCREW	SELF THREAD SCREW	M.S.	2
	PLAIN WASHER W TYPE	18.5X9X1.5	M.S.	6
	POWER FEED ALU BRACKET	144X37X5.5	ALUMINIUM	1
	GRUMET	Ø 30	RUBBER	2
	POWERFEED CLAMP W-TYPE	16.3X22X81	ALUMINIUM	1
	SPRING WASHER	M8	SPRING STEEL 4454 GRADE-02	6
8	SQUARE HEAD BOLT W- TYPE	18XM6	M.S.	4
	HEX BOLT	M8, 8X20	M.S.	2
	HEX NUT	M6	M.S.	4
	SINGLE POLE HANGER CLAMP W-TYPE ASSM	28X37X19.3		4
9	SINGLE POLE HANGER CLAMP W-TYPE			1
	HEX BOLT	M8, 8X20	M.S.	1
	HEX NUT	M8	M.S.	1
	PLAIN WASHER	M8	M.S.	1
10	SPRING WASHER	M8	SPRING STEEL 4454 GRADE-02	1
	EXPANSION JOINT ASSEMBLY W-TYPE	321X80X30		4
	CLAMP EXPANSION W-TYPE			1
	END CLAM EXPANSION	16.5X23.5X22	G.I	6
	DSL_NEW-1	DSL BUSBAR WITH SLEEVE		1
	WASHER-1	18X8X1.5	M.S.	1
	COPPER SLEEVE	20X20	COPPER	4
	COPPER SLEEVE 2	20X59	COPPER	2
	PLAIN WASHER	M6	M.S.	1
	NUT	M6	M.S.	1
11	COPPER-FLAT-COIL 2 W-TYPE		COPPER	2
	COPPER-FLAT-COIL-1 W-TYPE		COPPER	2
	EXPANSION JOINT COVER W-TYPW		DELTRIN	2
	SQUARE HEAD BOLT W- TYPE	18XM6	M.S.	6
	HEX BOLT	M4X10	M.S.	4
	HEX NUT	M4	M.S.	4
	CURRENT COLLECTOR 100 AMP ASSM	230X332		4
	ARM 1	220X15.5X3	M.S.	4
	LOWER BRACKET	56X73X30	CASTING	1
	LOWER PIN	16X70	M.S.	1
12	VERTICAL LEVER CC	50X61X24	CASTING	1
	SPACER PIN	26X Ø 6	M.S.	6
	UPPER BRACKET	108.5X43X10	PLASTIC	2
	VERTICAL STUD	104X Ø 7	M.S.	1
	SHOE HOLDER	108.5X20X40	PLASTIC	1
	CONTACT PATTI	87X47X3	COPPER	1
	SPRING	Ø 13.5X22	SPRING STEEL 4454 GRADE-02	1
	LOWER BRACKET CC 2	70X30X3	M.S.	1
	HEX BOLT	8X40	M.S.	2
	NUT	M8	M.S.	2
13	PLAIN WASHER W TYPE	18.5X9X1.5	M.S.	2
	HEX NUT	M4	M.S.	2
	TENSION SPRING	Ø 15X115	SPRING STEEL 4454 GRADE-02	1
	wire	105 SQ MM, 1mtr		1
14	C.C-Bracket 100 AMP	80X60XTHK-6, SQ-25X25X400	M.S.	1
	END CLAMP ASSEMBLY W TYPE			8
	END CLAMP W TYPE			8
	SQUARE HEAD BOLT W- TYPE	18XM6	M.S.	8
15	HEX NUT	M6	M.S.	8
	SPRING WASHER M6 W TYPE	M6	SPRING STEEL 4454 GRADE-02	8
	PLAIN WASHER	M8	M.S.	8
	END POWER FEED COVER W-TYPE	112X30X35	PVC	3
15	END COVER W TYPE	73X39X30	PVC	4
	TRANSFER CAP ASSM W-TYPE			1
	HEX BOLT	M8X50	M.S.	1
	NUT	M8	M.S.	2
	PLAIN WASHER	M8	M.S.	1
	SPRING WASHER	M8	SPRING STEEL 4454 GRADE-02	1
15	TRANSFER CAP BODY W-TYPE	37.5X33.5X89.3		1
	TRANSFER CAP M.S. PLATE W-TYPE 2D.PDF	75 X36X6	M.S.	1

EXPLODED VIEW

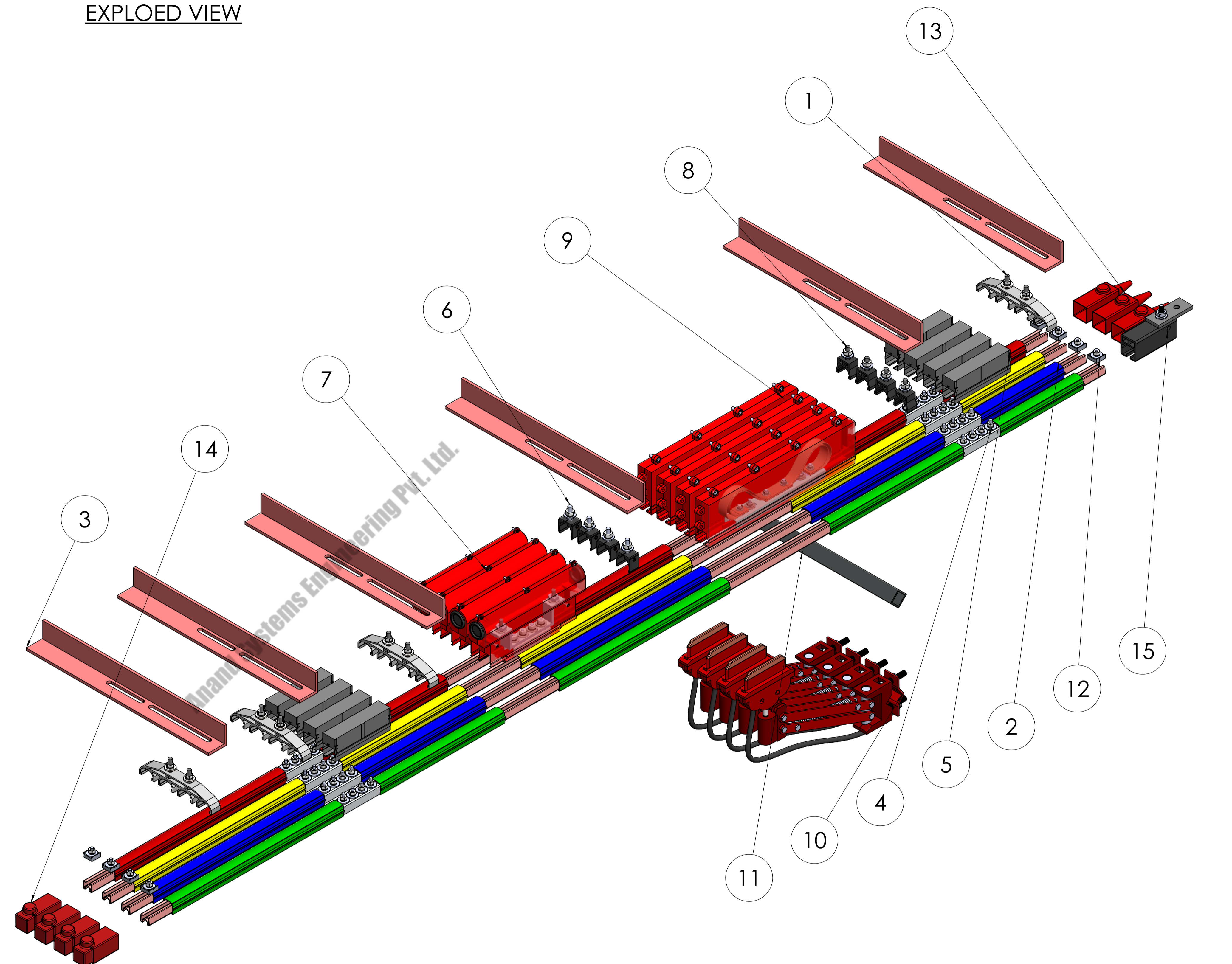

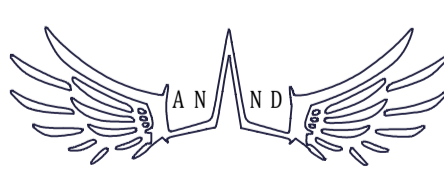
COMPANY NAME:		ANAND SYSTEM ENGINEERING PVT LTD		DO NOT SCALE DRAWING	REVISION:
		ANAND SYSTEM ENGINEERING PVT LTD		TITLE: W TYPE (BOLT TYPE) ASSEMBLY 2D	
Email id: info@anandcontrol.in		FENISE:		DWG. NO.:	
CONTACT NO: 9137620579				DATE: SIGNATURE:	
DRWN: SAURABH	CHKD: AJAY	MATERIAL:		A	
APPD:		WEIGHT:		SCALE: SHEET: 1 OF 1	
MFC:					

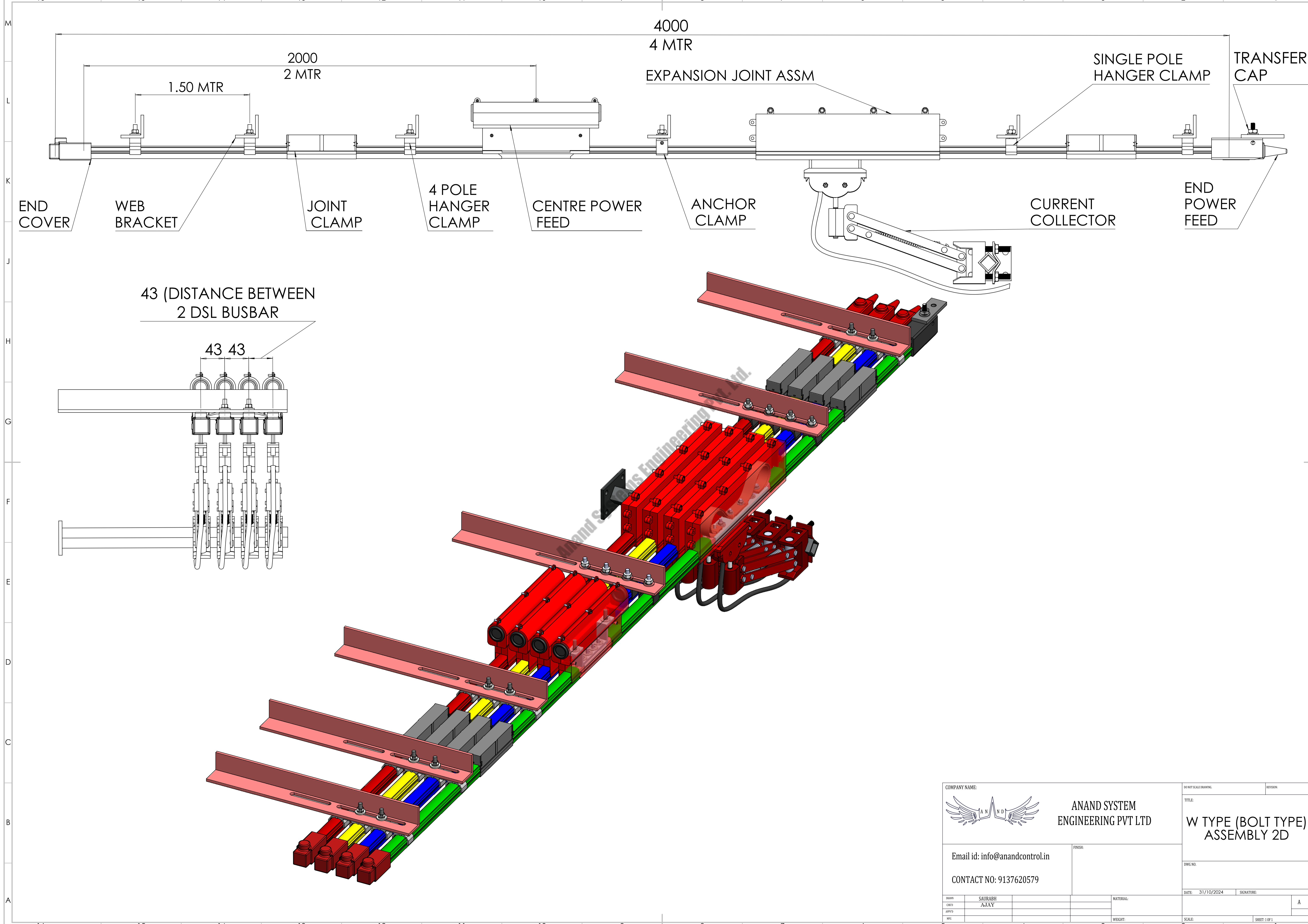

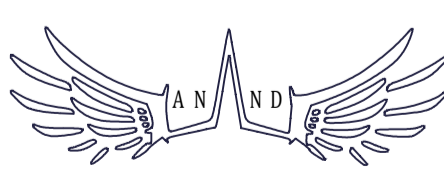
COMPANY NAME:		ANAND SYSTEM ENGINEERING PVT LTD		DO NOT SCALE DRAWING	REVISION:
		Email id: info@anandcontrol.in CONTACT NO: 9137620579		TITLE: W TYPE (BOLT TYPE) ASSEMBLY 2D	
DATE: 31/10/2024	SIGNATURE:	DWG. NO.:		SHEET: 1 OF 1	
DRWN: SAURABH	CHKD: AJAY	MATERIAL:	WEIGHT:	A	

4

3

2

1

F

F

E

E

D

D

C

C

B

B

A

A

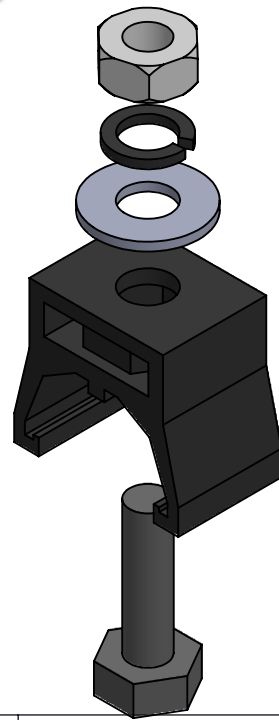
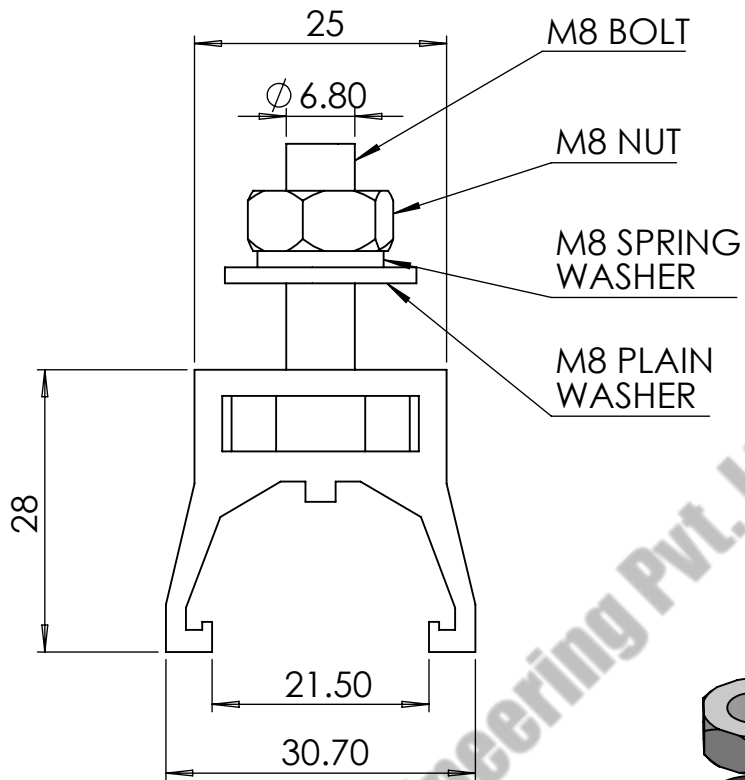

Anand Systems Engineering Pvt. Ltd.

COMPANY NAME:



**ANAND SYSTEM
ENGINEERING PVT LTD**

DO NOT SCALE DRAWING

REVISION:

TITLE:

**SINGLE POLE
HANGER CLAMP
W-TYPE ASSM 2D**

Email id: info@anandcontrol.in

CONTACT NO: 9137620579

FINISH:

DWG NO.

DATE:

SIGNATURE:

DRAWN	SAURABH
CHK'D	
APP'D	
MFG	

MATERIAL:

WEIGHT:

SCALE:

SHEET: 1 OF 1

4

3

2

1

4

3

2

1

F

F

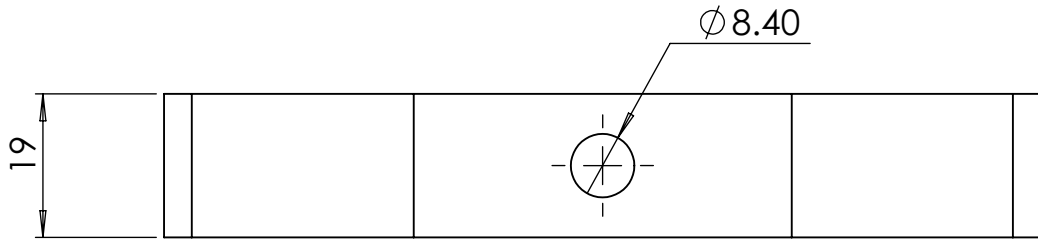

E

E

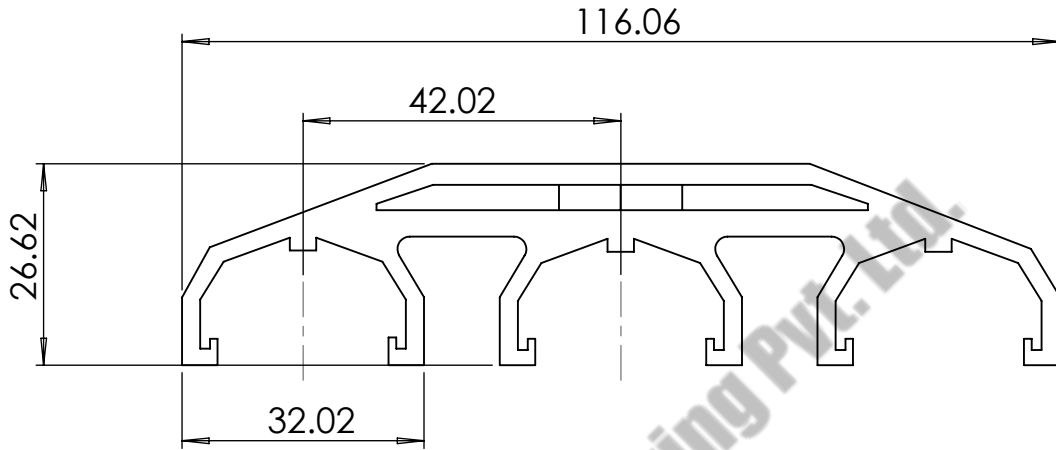

D

D

C

C

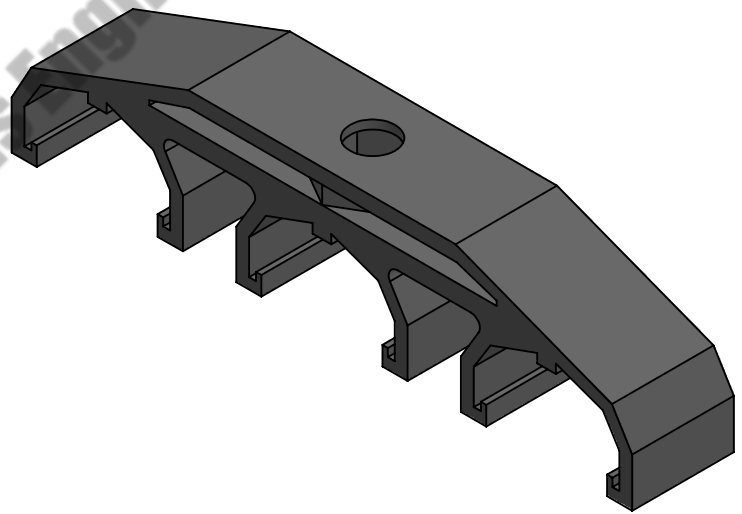

B

B

COMPANY NAME:



ANAND SYSTEM
ENGINEERING PVT LTD

DO NOT SCALE DRAWING.

REVISION:

TITLE:

3 POLE HANGER
CLAMP W TYPE
2D

Email id: info@anandcontrol.in

CONTACT NO: 9137620579

FINISH:

DWG NO.

DATE:

SIGNATURE:

A

A

DRAWN	SAURABH
CHK'D	
APP'D	
MFG	

MATERIAL:

WEIGHT:

SCALE:

SHEET: 1 OF 1

4

3

2

1

4

3

2

1

F

F

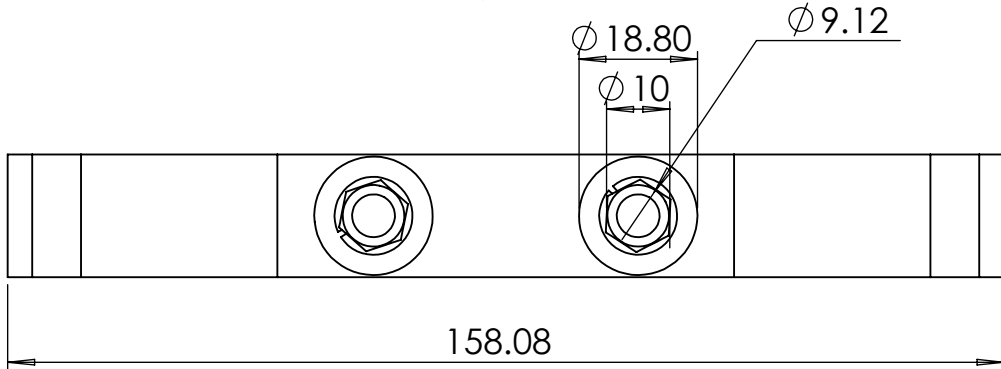

E

E

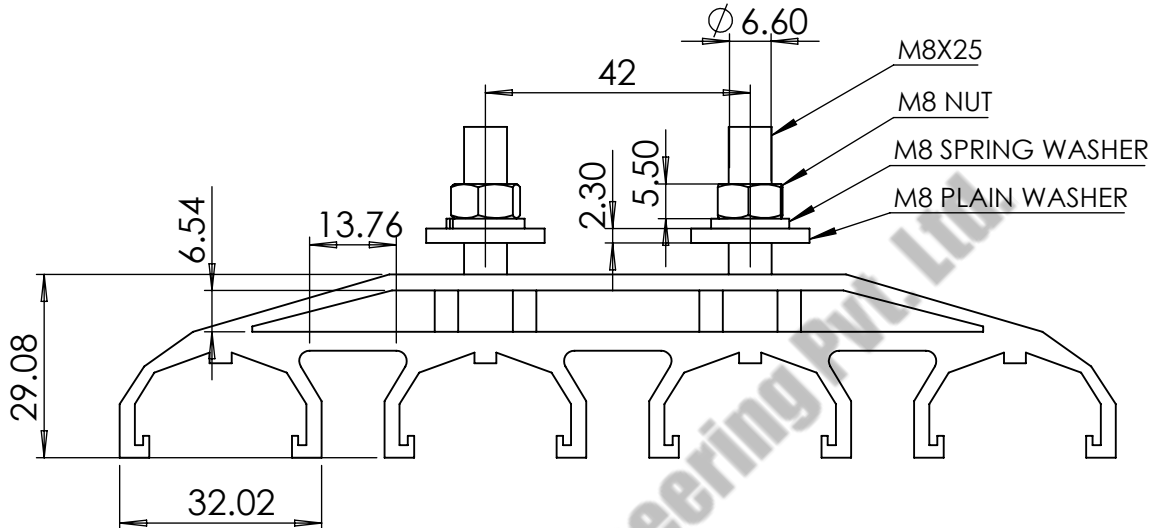

D

D

C

C

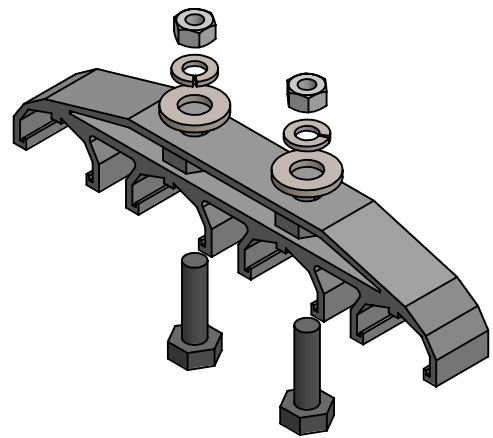

Anand Systems Engineering Pvt Ltd

B

B

COMPANY NAME:



**ANAND SYSTEM
ENGINEERING PVT LTD**

DO NOT SCALE DRAWING.

REVISION:

TITLE:

**4 POLE HANGER
CLAMP W
TYPE.ASSEMBLY 2D**

A

A

Email id: info@anandcontrol.in

CONTACT NO: 9137620579

FINISH:

DWG NO.

DATE:

SIGNATURE:

A

DRAWN	SAURABH
CHK'D	
APP'D	
MFG	

MATERIAL:

WEIGHT:

SCALE:

SHEET: 1 OF 1

4

3

2

1

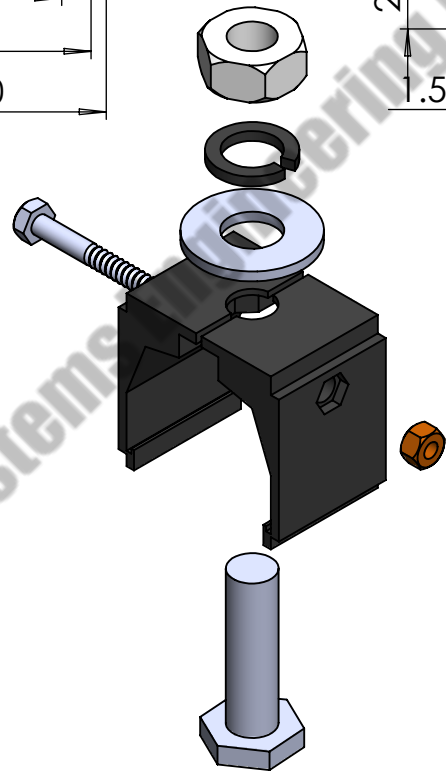
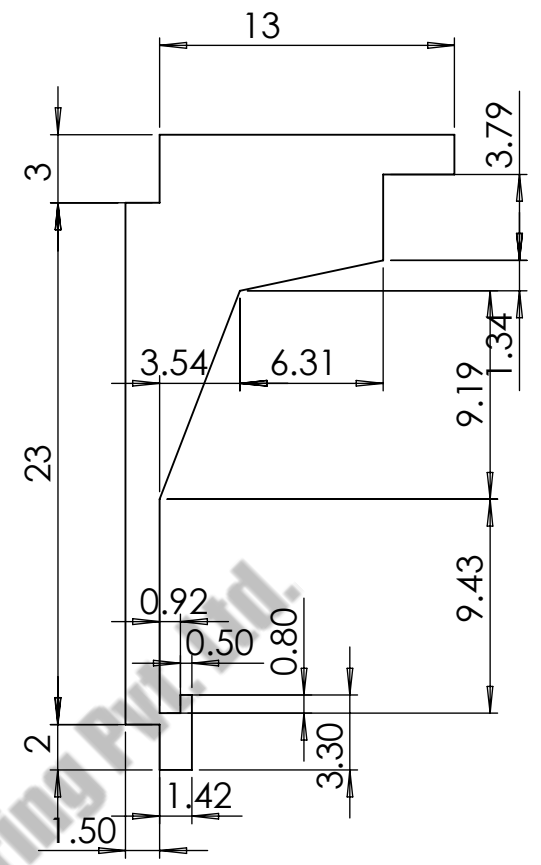
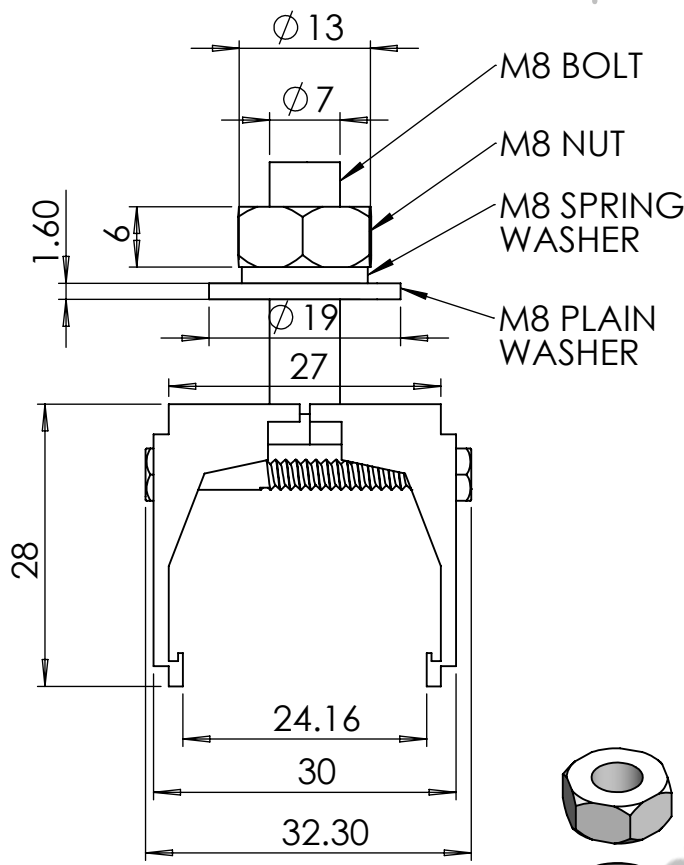

COMPANY NAME:



ANAND SYSTEM
ENGINEERING PVT LTD

DO NOT SCALE DRAWING.

REVISION:

TITLE:

ANCHOR CLAMP
ASSEMBLY W TYPE
2D

Email id: info@anandcontrol.in

CONTACT NO: 9137620579

FINISH:

DWG NO.

28X30X20

DATE:

SIGNATURE:

DRAWN	SAURABH
CHK'D	
APP'D	
MFG	

MATERIAL:

A

WEIGHT:

SCALE:

SHEET: 1 OF 1

4

3

2

1

F

F

E

E

D

D

C

C

B

B

A

A

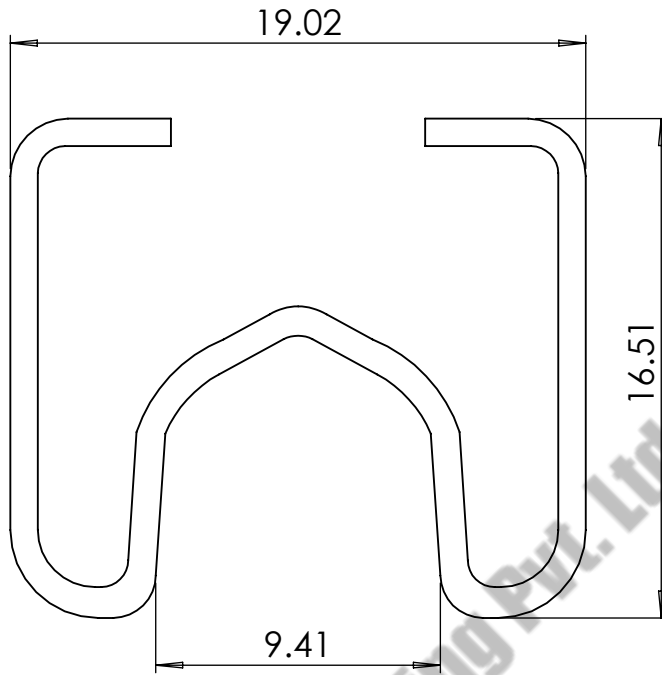

Anand Systems Engineering Pvt. Ltd.

COMPANY NAME:



**ANAND SYSTEM
ENGINEERING PVT LTD**

DO NOT SCALE DRAWING.

REVISION:

TITLE:

**AL-CU W TYPE
DSL 2D**

Email id: info@anandcontrol.in

CONTACT NO: 9137620579

FINISH:

DWG NO.

DATE:

SIGNATURE:

DRAWN	SAURABH
CHK'D	
APP'D	
MFG	

MATERIAL:

WEIGHT:

SCALE:

SHEET: 1 OF 1

4

3

2

1

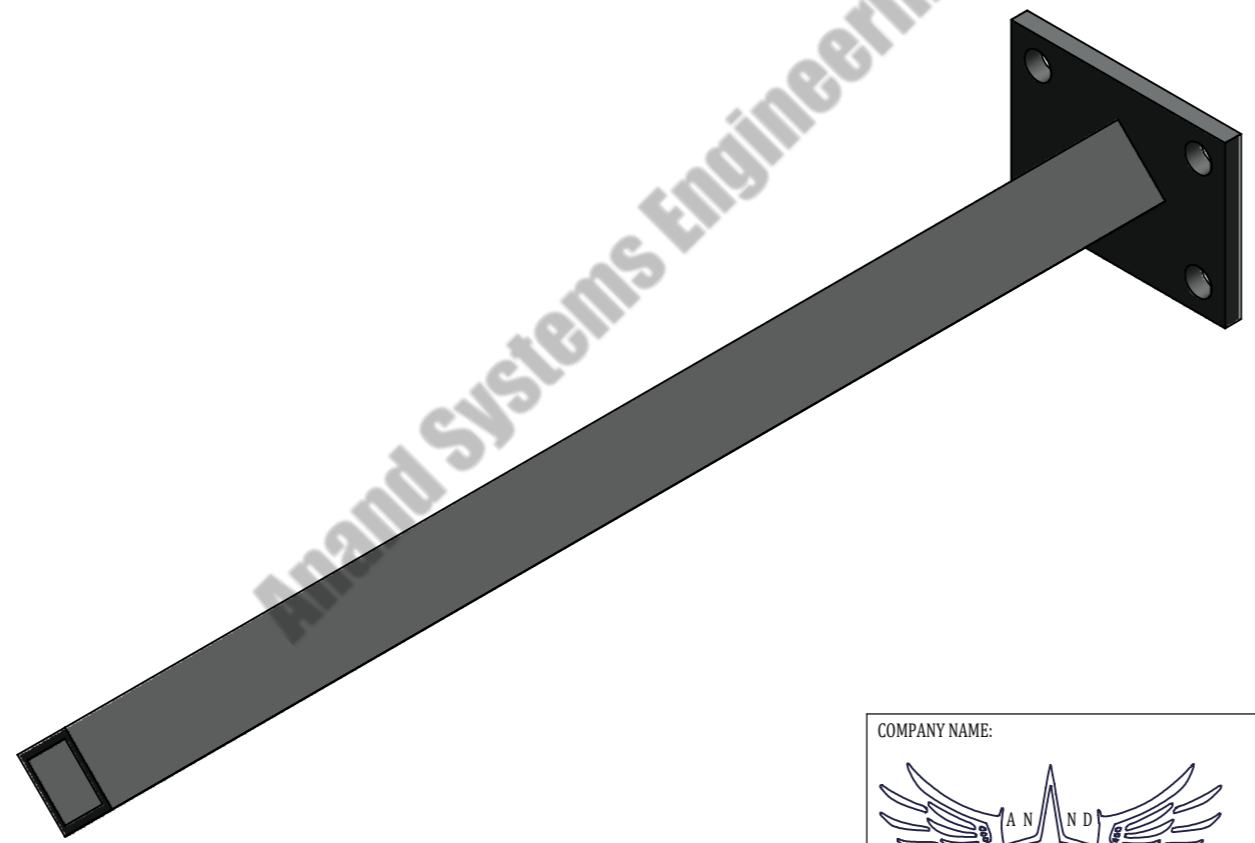
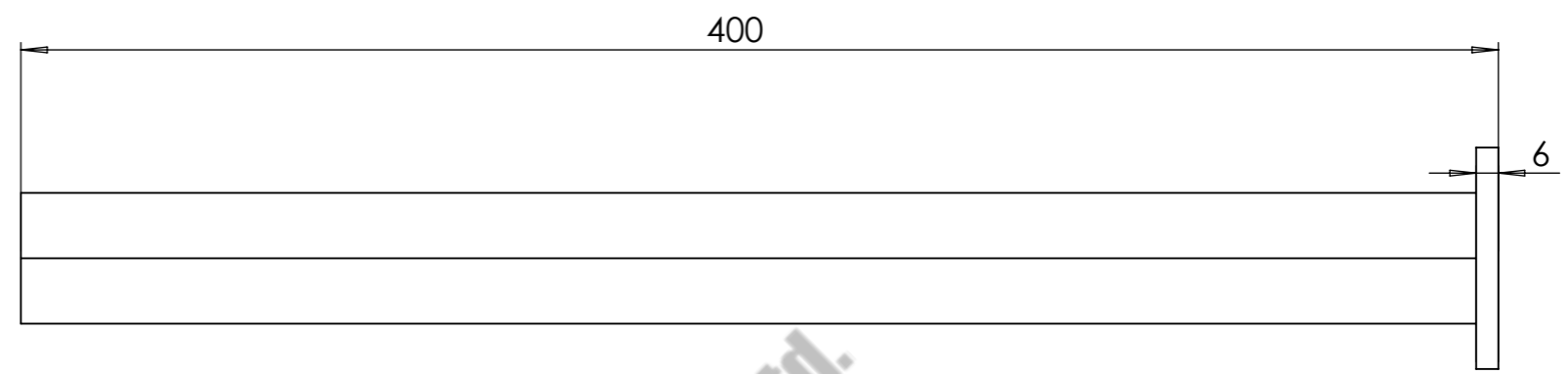
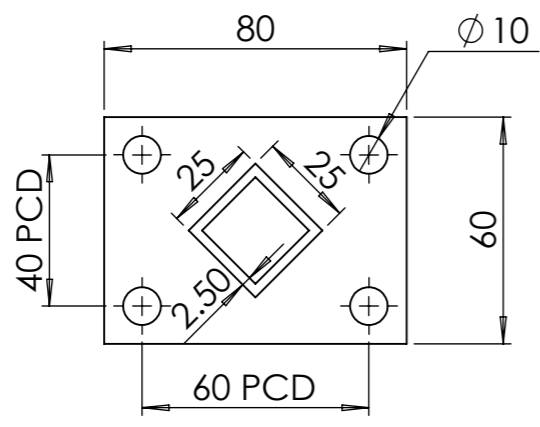

Anand Systems Engineering Pvt. Ltd.

COMPANY NAME:		ANAND SYSTEM ENGINEERING PVT LTD		DO NOT SCALE DRAWING.	REVISION:
		Email id: info@anandcontrol.in CONTACT NO: 9137620579		TITLE: <h1>C.C-Bracket 100 AMP</h1>	
FINISH:		MATERIAL:		DWG NO.	
DATE:		SIGNATURE:		A	
DRAWN	SAURABH			SCALE:	
CHK'D				SHEET: 1 OF 1	
APP'VD					
MFG					

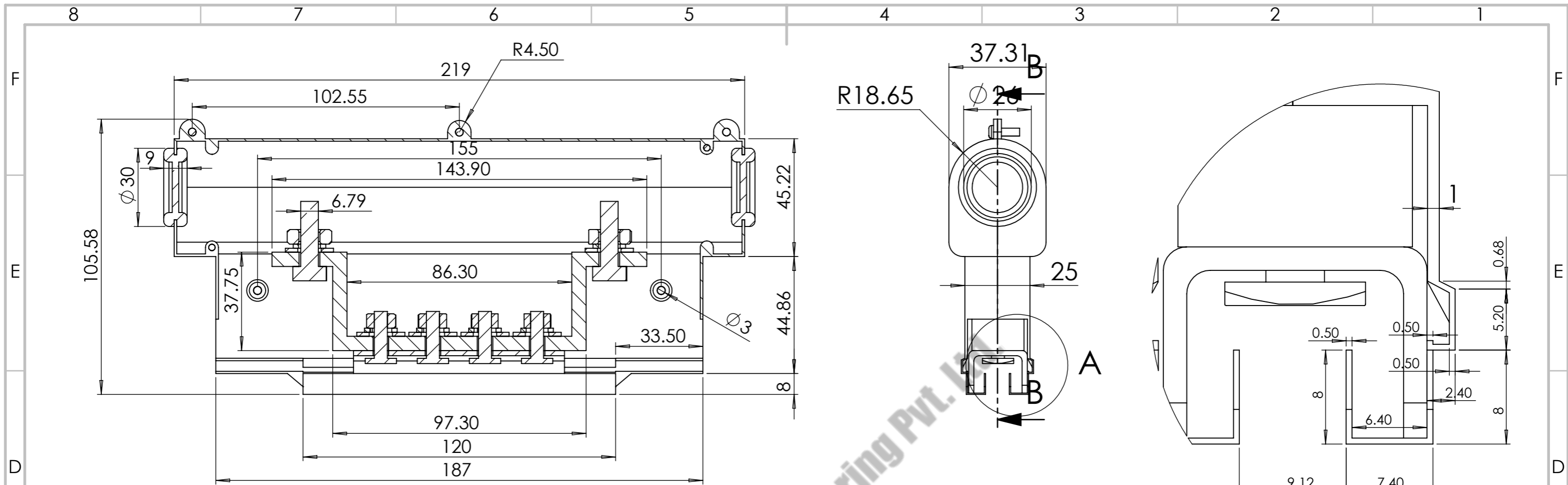

SECTION B-B
SCALE 1 : 1.5

DETAIL A
SCALE 3 : 1

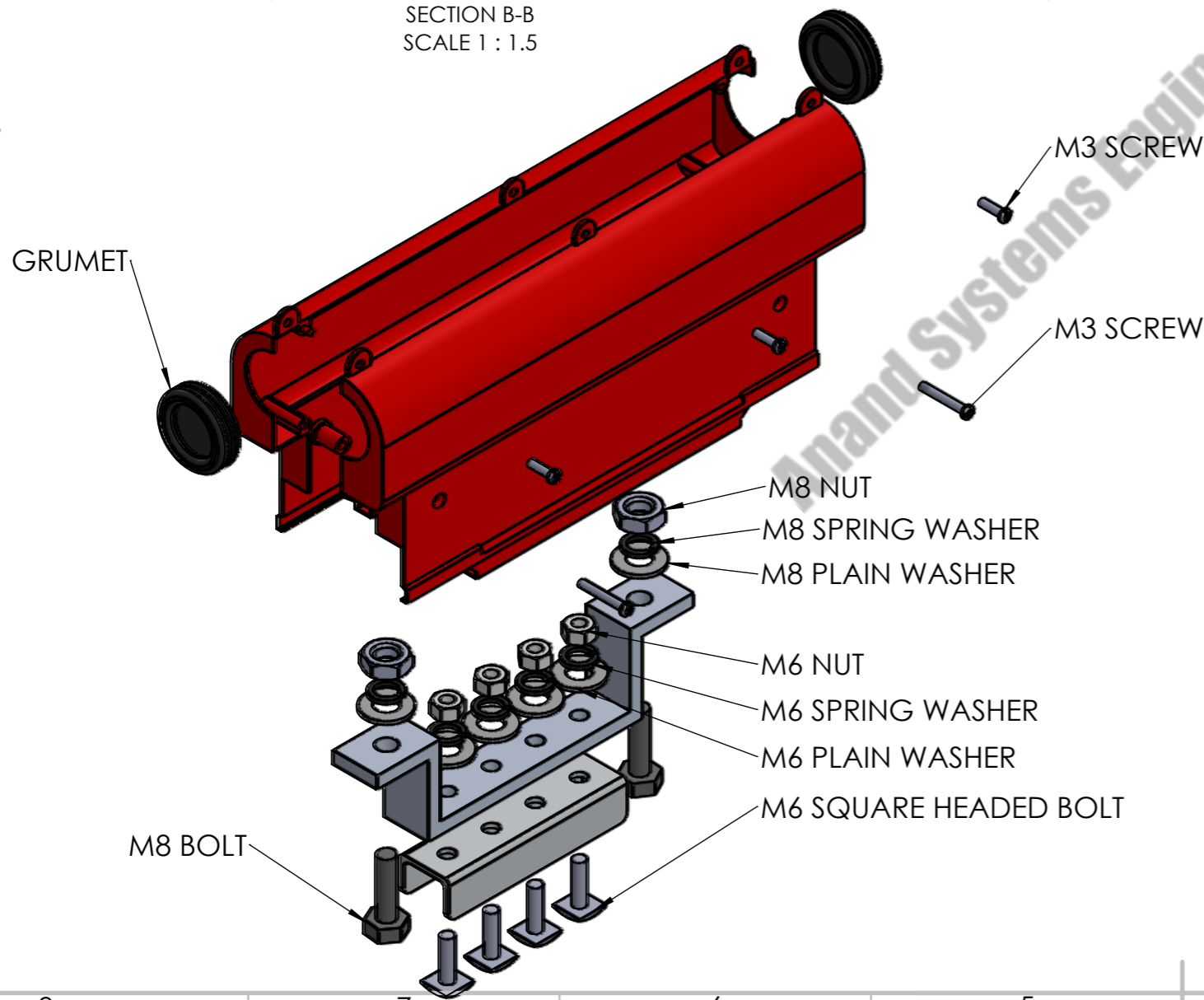

COMPANY NAME:		ANAND SYSTEM ENGINEERING PVT LTD		DO NOT SCALE DRAWING:	REVISION:
		Email id: info@anandcontrol.in CONTACT NO: 9137620579		TITLE: CENTER POWERFEED ASSEMBLY W-TYPE 2D	
FINISH:		MATERIAL:		DWG NO: 219X105.6X37	
DATE:	SIGNATURE:		A		
SCALE:	SHEET: 1 OF 1				
DRAWN: SAURABH	MATERIAL:				
CHK'D:	WEIGHT:				
APP'D:					
MFG:					

4

3

2

1

F

F

E

E

D

D

C

C

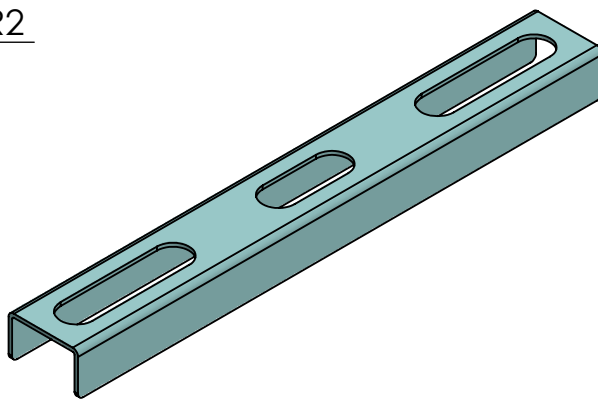
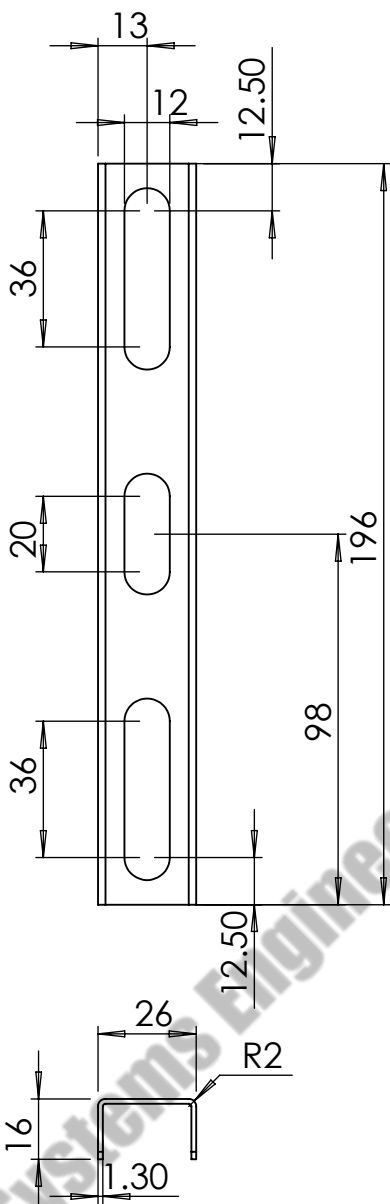

Anand Systems Engineering Pvt. Ltd.

B

B

COMPANY NAME:



ANAND SYSTEM
ENGINEERING PVT LTD

DO NOT SCALE DRAWING.

REVISION:

TITLE:

CLAMP
EXPANSION
W-TYPE 2D

DWG NO.

A

A

Email id: info@anandcontrol.in

CONTACT NO: 9137620579

FINISH:

DATE:

SIGNATURE:

A

DRAWN	SAURABH
CHK'D	
APP'D	
MFG	

MATERIAL:

WEIGHT:

SCALE:

SHEET: 1 OF 1

4

3

2

1

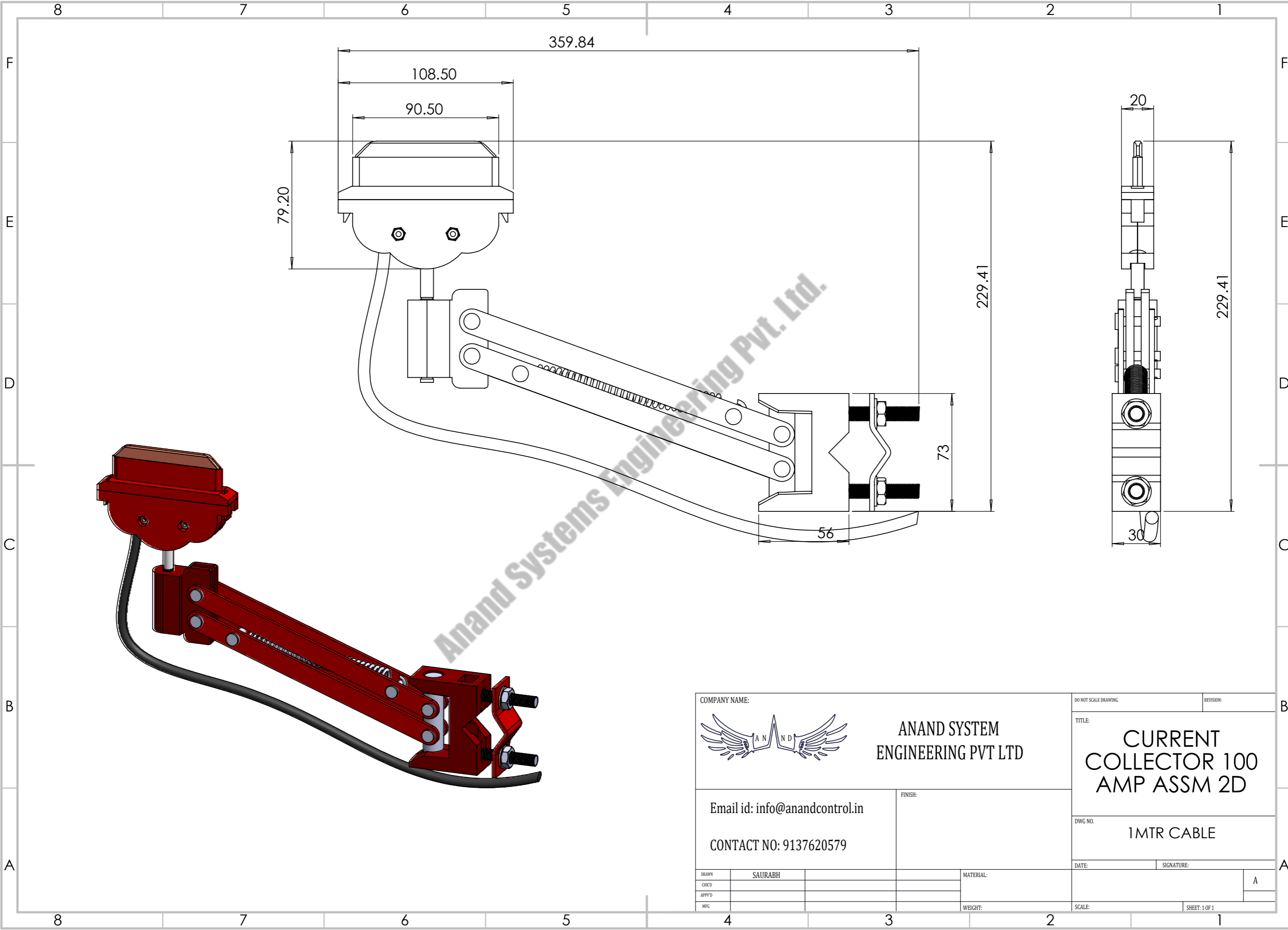

Anand Systems Engineering Pvt. Ltd.

COMPANY NAME:		ANAND SYSTEM ENGINEERING PVT LTD		DO NOT SCALE DRAWING.	REVISION:
		Email id: info@anandcontrol.in CONTACT NO: 9137620579		TITLE: CURRENT COLLECTOR 100 AMP ASSM 2D	
FINISH:		MATERIAL:		DWG NO. 1MTR CABLE	
DATE:		SIGNATURE:		A	
DRAWN	SAURABH			SCALE:	
CHK'D				SHEET: 1 OF 1	
APPY'D					
MFG					

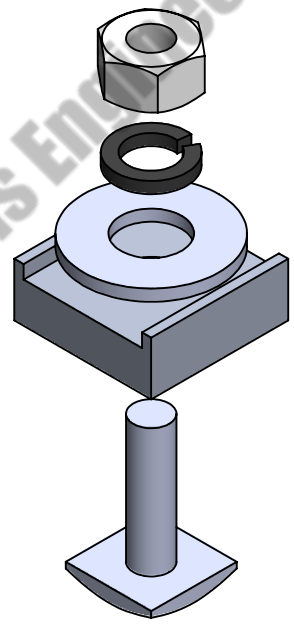
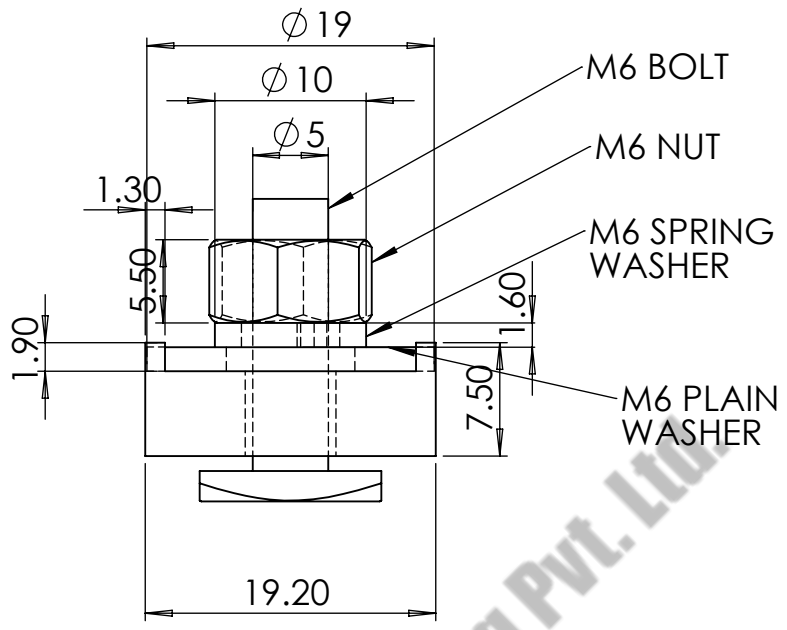

Anand Systems Engineering Pvt. Ltd.

COMPANY NAME:



ANAND SYSTEM
ENGINEERING PVT LTD

DO NOT SCALE DRAWING.

REVISION:

TITLE:

END CLAMP
ASSEMBLY W
TYPE 2D

Email id: info@anandcontrol.in

CONTACT NO: 9137620579

FINISH:

DWG NO.

DATE:

SIGNATURE:

DRAWN	SAURABH
CHK'D	
APP'D	
MFG	

MATERIAL:

WEIGHT:

SCALE:

SHEET: 1 OF 1

A

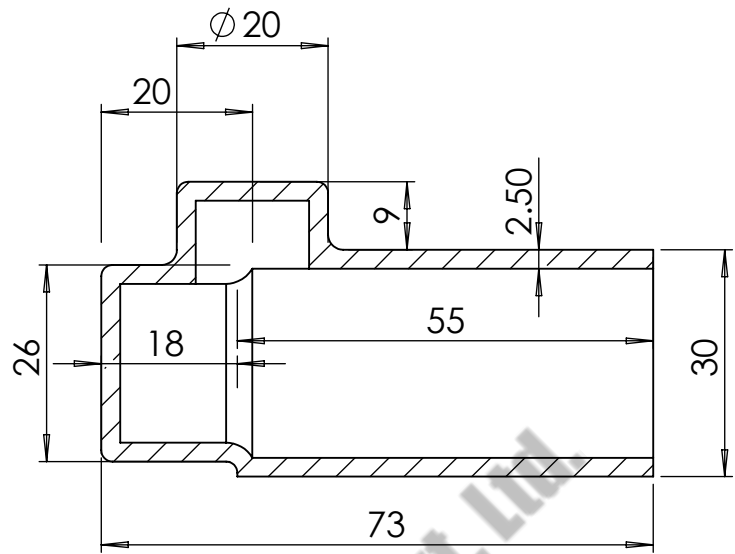
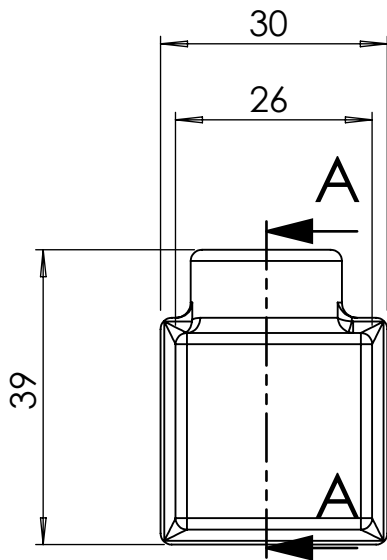

SECTION A-A

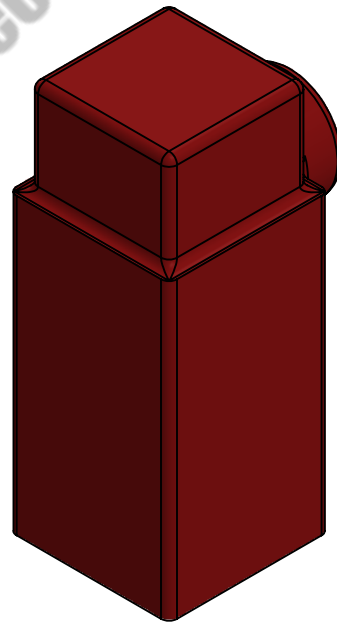

Anand Systems Engineering Pvt. Ltd.

COMPANY NAME:  <p style="text-align: center; font-weight: bold; font-size: 1.2em;">ANAND SYSTEM ENGINEERING PVT LTD</p>		DO NOT SCALE DRAWING. REVISION: TITLE: <p style="text-align: center; font-size: 1.5em; font-weight: bold;">END COVER W TYPE 2D</p>	
Email id: info@anandcontrol.in CONTACT NO: 9137620579		DWG NO.: DATE: SIGNATURE:	
DRAWN: SAURABH CHK'D: APP'D: MFG:		FINISH: MATERIAL: WEIGHT:	SCALE: SHEET: 1 OF 1

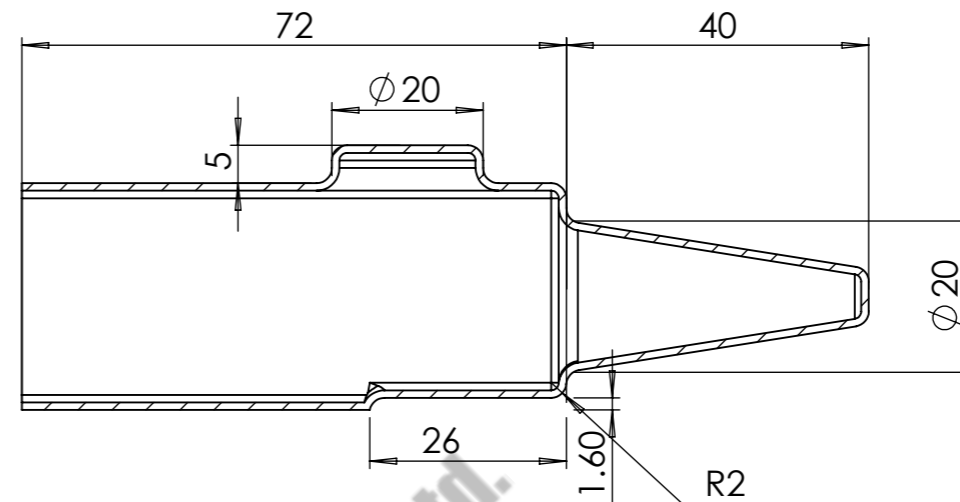
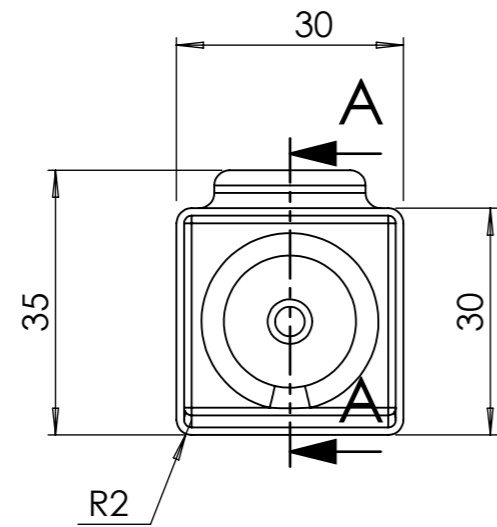

SECTION A-A

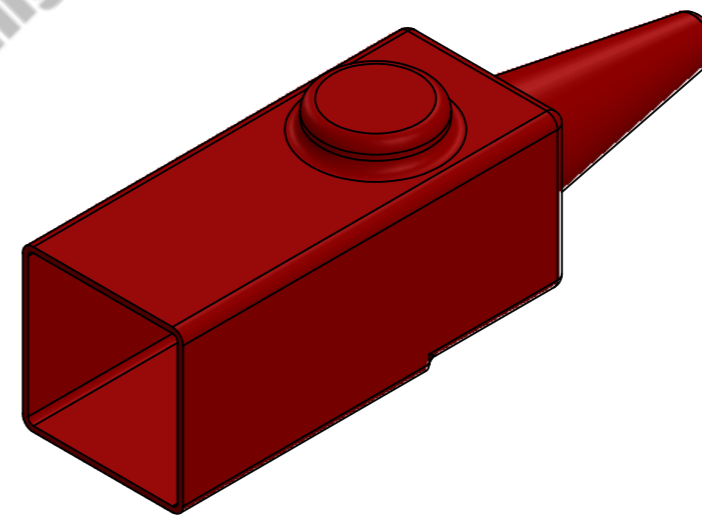
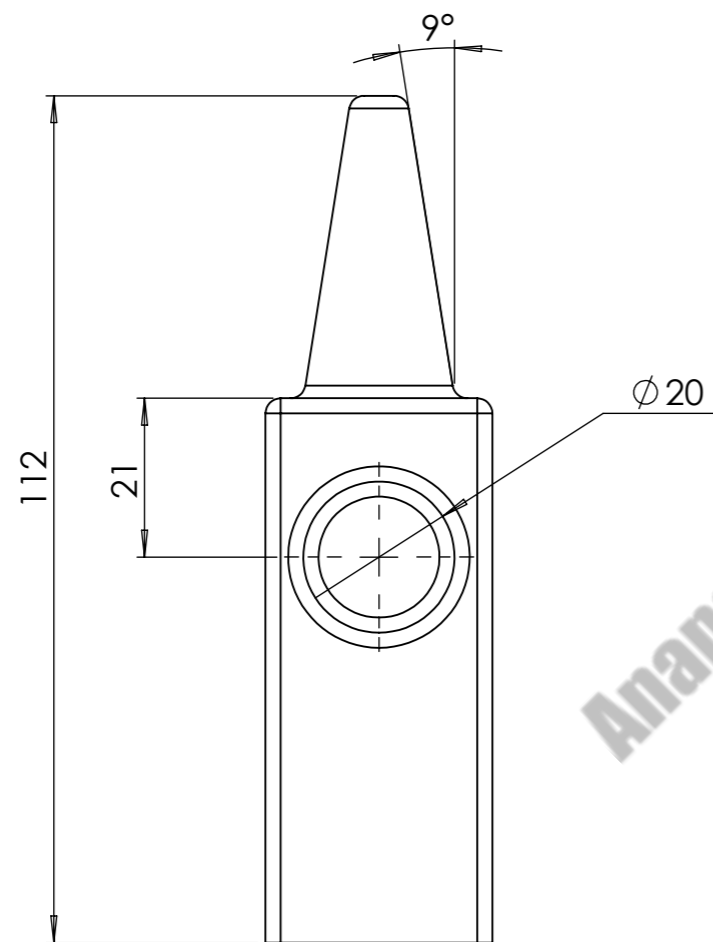

Anand Systems Engineering Pvt.Ltd.

COMPANY NAME:



**ANAND SYSTEM
ENGINEERING PVT LTD**

Email id: info@anandcontrol.in

CONTACT NO: 9137620579

FINISH:

DO NOT SCALE DRAWING.

REVISION:

TITLE:

**END POWER FEED
W-TYPE 2D**

DWG NO.

DATE:

SIGNATURE:

DRAWN
CHK'D
APPV'D
MFG

SAURABH

MATERIAL:

WEIGHT:

SCALE:

SHEET: 1 OF 1

A

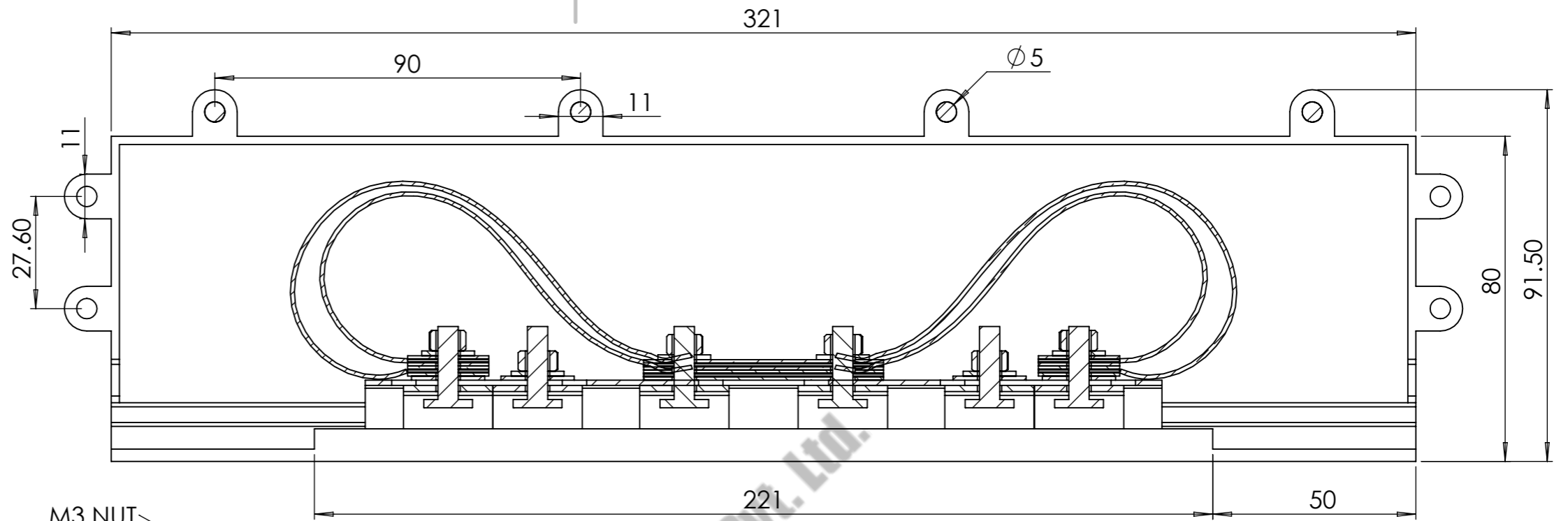
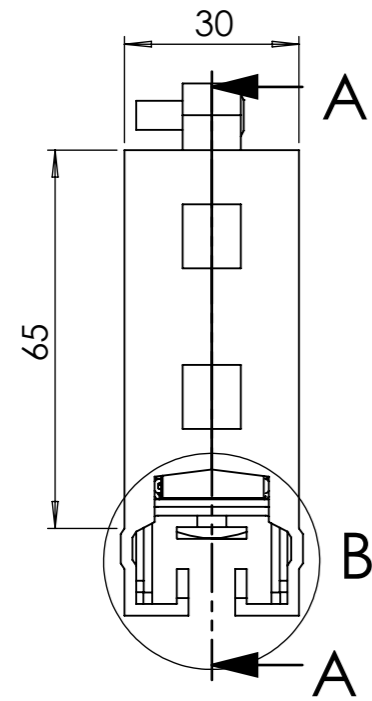

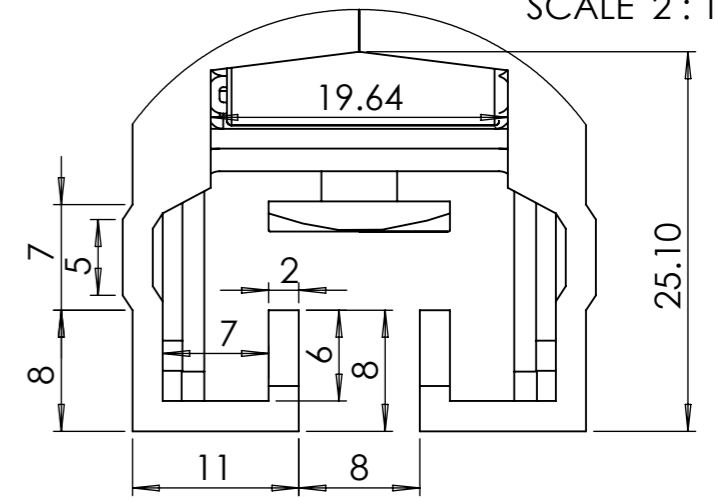
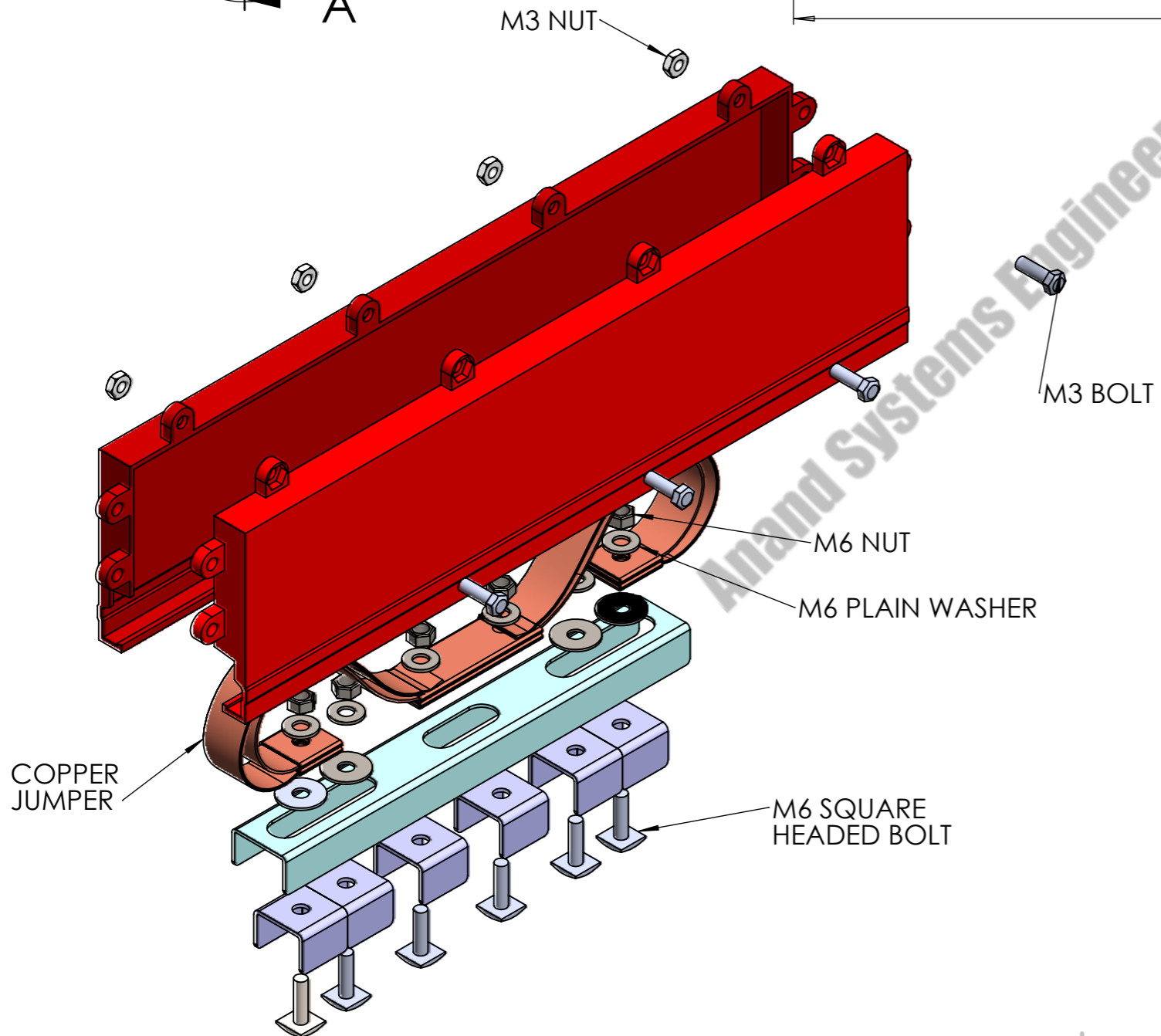

SECTION A-A
SCALE 1 : 1.3

DETAIL B
SCALE 2 : 1

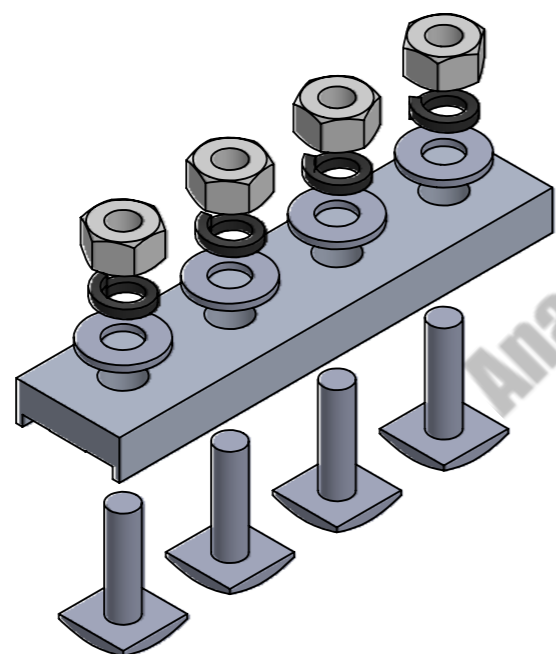
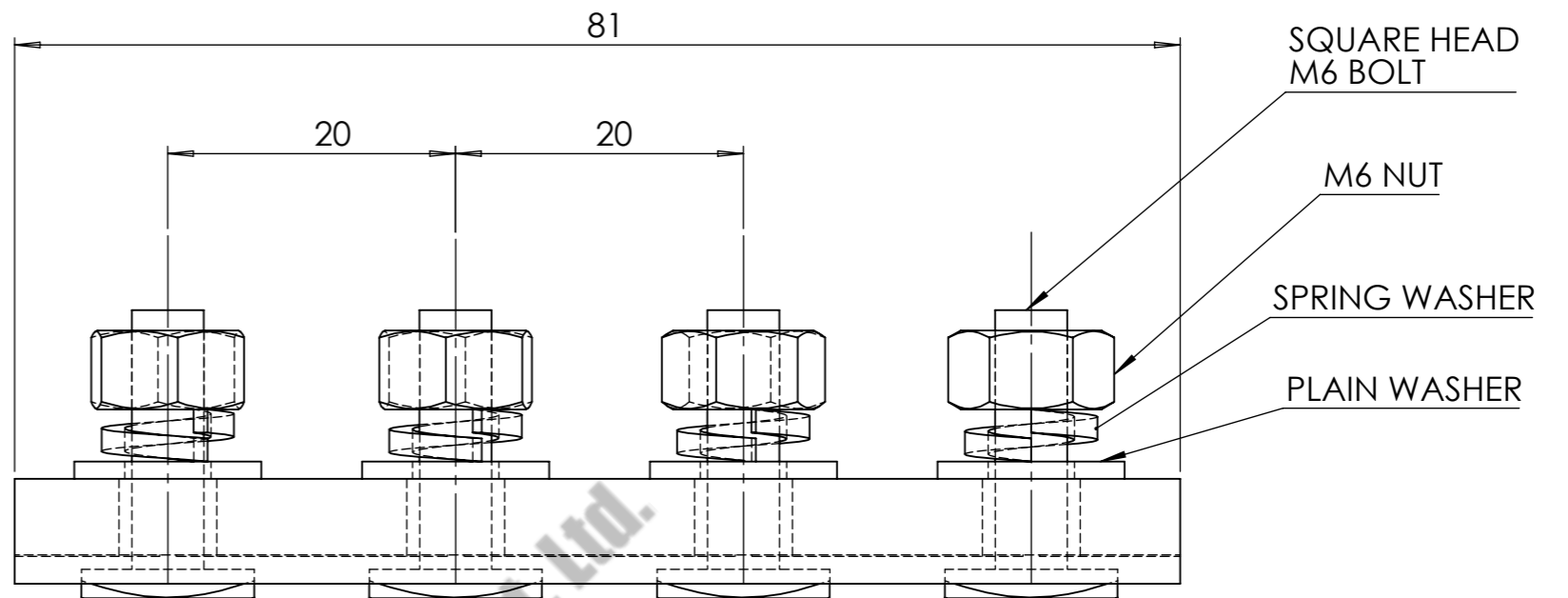
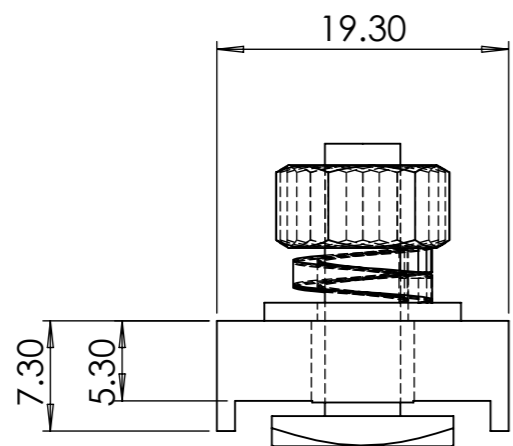

COMPANY NAME:		ANAND SYSTEM ENGINEERING PVT LTD		DO NOT SCALE DRAWING.	REVISION:
		<p>Email id: info@anandcontrol.in</p> <p>CONTACT NO: 9137620579</p>		<p>TITLE:</p> <p>EXPANSION JOINT ASSEMBLY W-TYPE 2D</p>	
FINISH:		MATERIAL:		DWG NO.	
DATE:		SIGNATURE:		SCALE:	
DRAWN	SAURABH			SHEET: 1 OF 1	
CHK'D				A	
APP'D					
MFG					



COMPANY NAME:		ANAND SYSTEM ENGINEERING PVT LTD		DO NOT SCALE DRAWING.	REVISION:
		<p>Email id: info@anandcontrol.in</p> <p>CONTACT NO: 9137620579</p>		<p>TITLE:</p> <p>JOINT CLAMP ASSEMBLY W TYPE 2D ALU 1</p>	
FINISH:		MATERIAL:		DWG NO.	
DATE:		SIGNATURE:		A	
DRAWN	SAURABH	MATERIAL:		SCALE:	
CHK'D		WEIGHT:		SHEET: 1 OF 1	
APPY'D					
MFG					

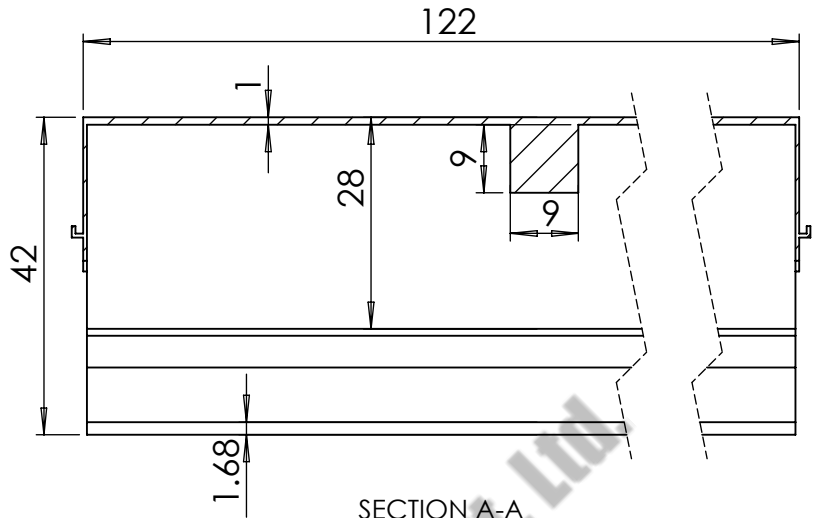
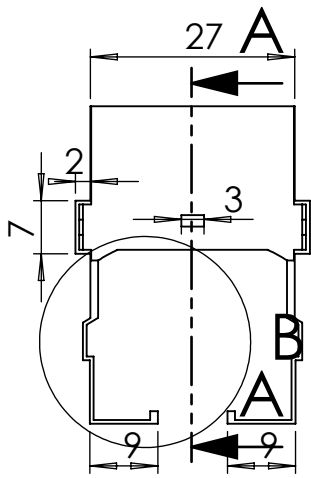

SECTION A-A
SCALE 1 : 1

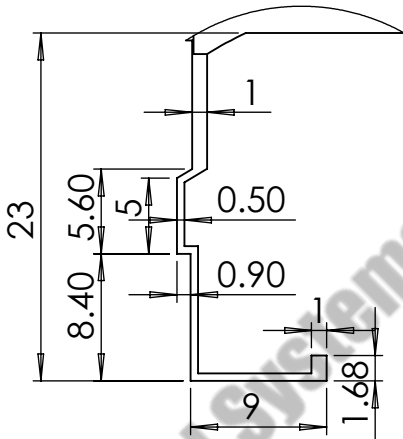

DETAIL B
SCALE 2 : 1

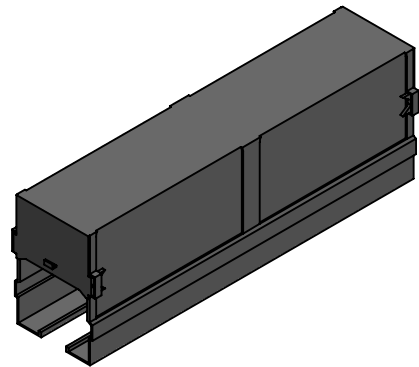

COMPANY NAME:



**ANAND SYSTEM
ENGINEERING PVT LTD**

DO NOT SCALE DRAWING.

REVISION:

TITLE:

**JOINT COVER
W-TYPE 2D**

Email id: info@anandcontrol.in

CONTACT NO: 9137620579

FINISH:

DWG NO.

DATE:

SIGNATURE:

DRAWN	SAURABH
CHK'D	
APP'D	
MFG	

MATERIAL:

WEIGHT:

SCALE:

SHEET: 1 OF 1

A

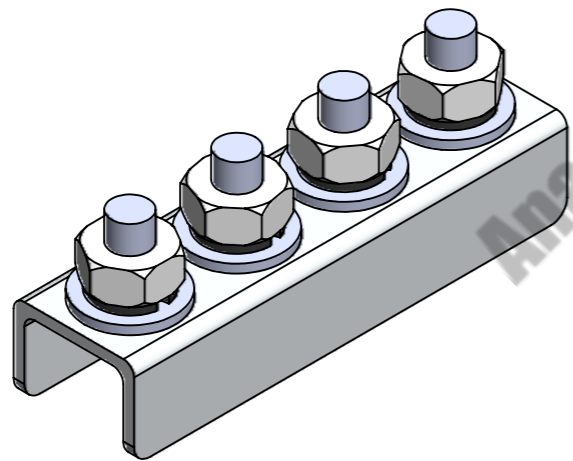
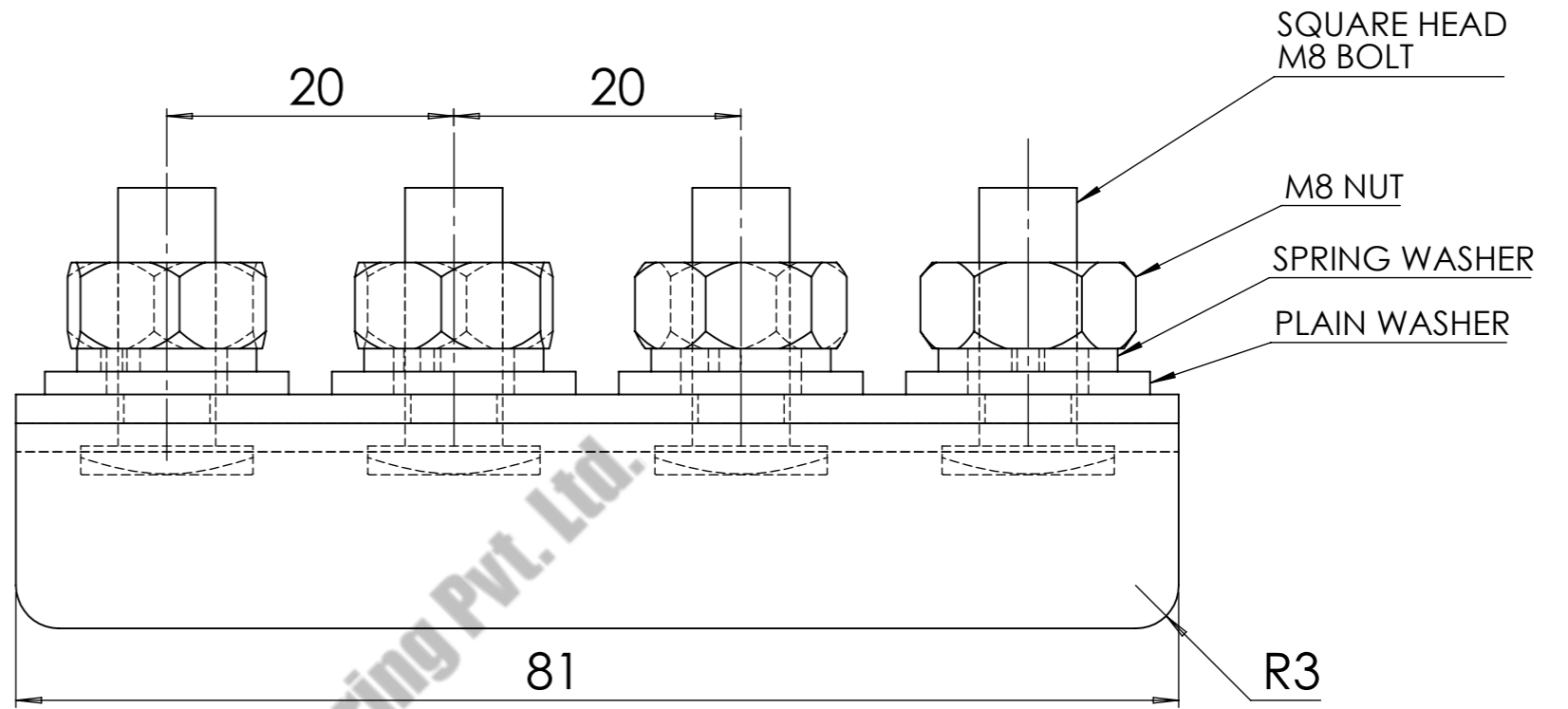
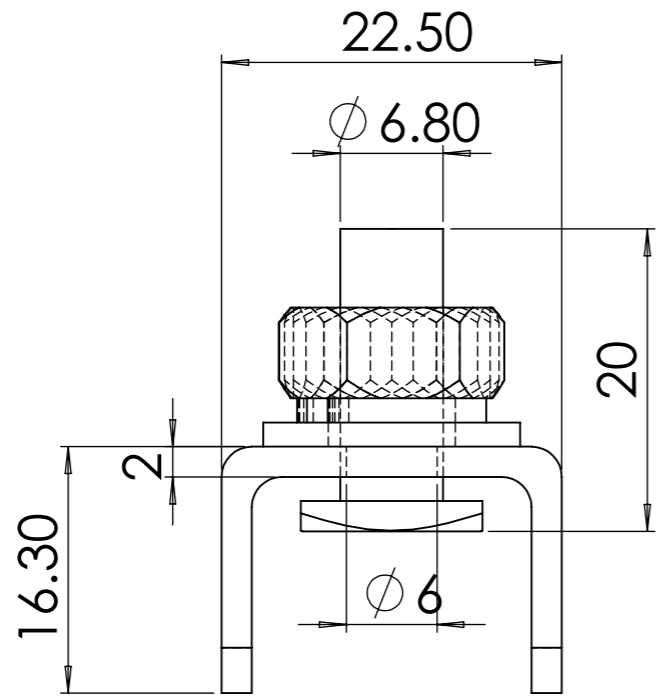

COMPANY NAME:		ANAND SYSTEM ENGINEERING PVT LTD		DO NOT SCALE DRAWING:	REVISION:
		<p>ANAND SYSTEM ENGINEERING PVT LTD</p>		TITLE: POWER FEED CLAMP ASSEMBLY W TYPE 2D ALU	
Email id: info@anandcontrol.in		FINISH:		DWG NO.	
CONTACT NO: 9137620579				DATE:	SIGNATURE:
DRAWN	SAURABH	MATERIAL:		A	
CHK'D					
APPY'D					
MFG		WEIGHT:		SCALE:	SHEET: 1 OF 1

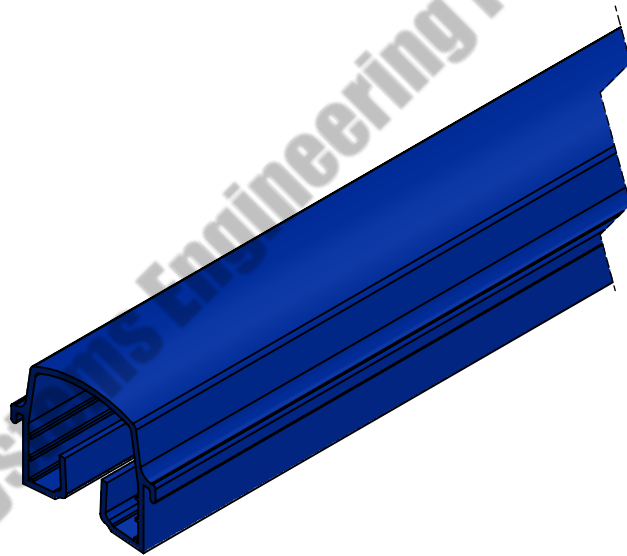
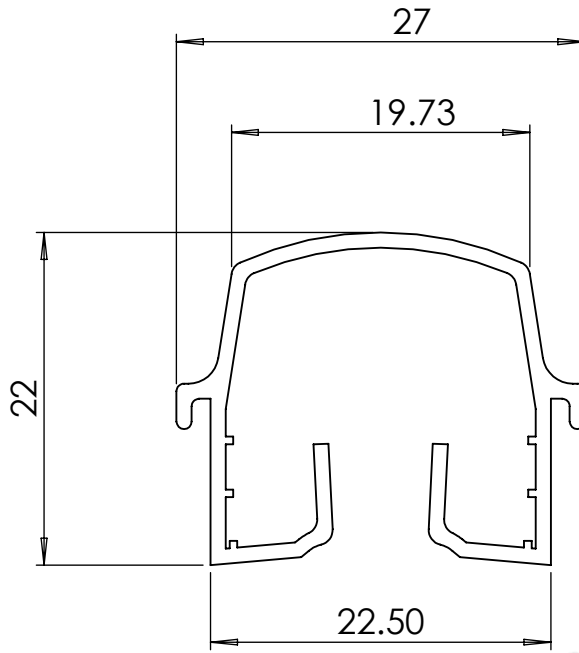

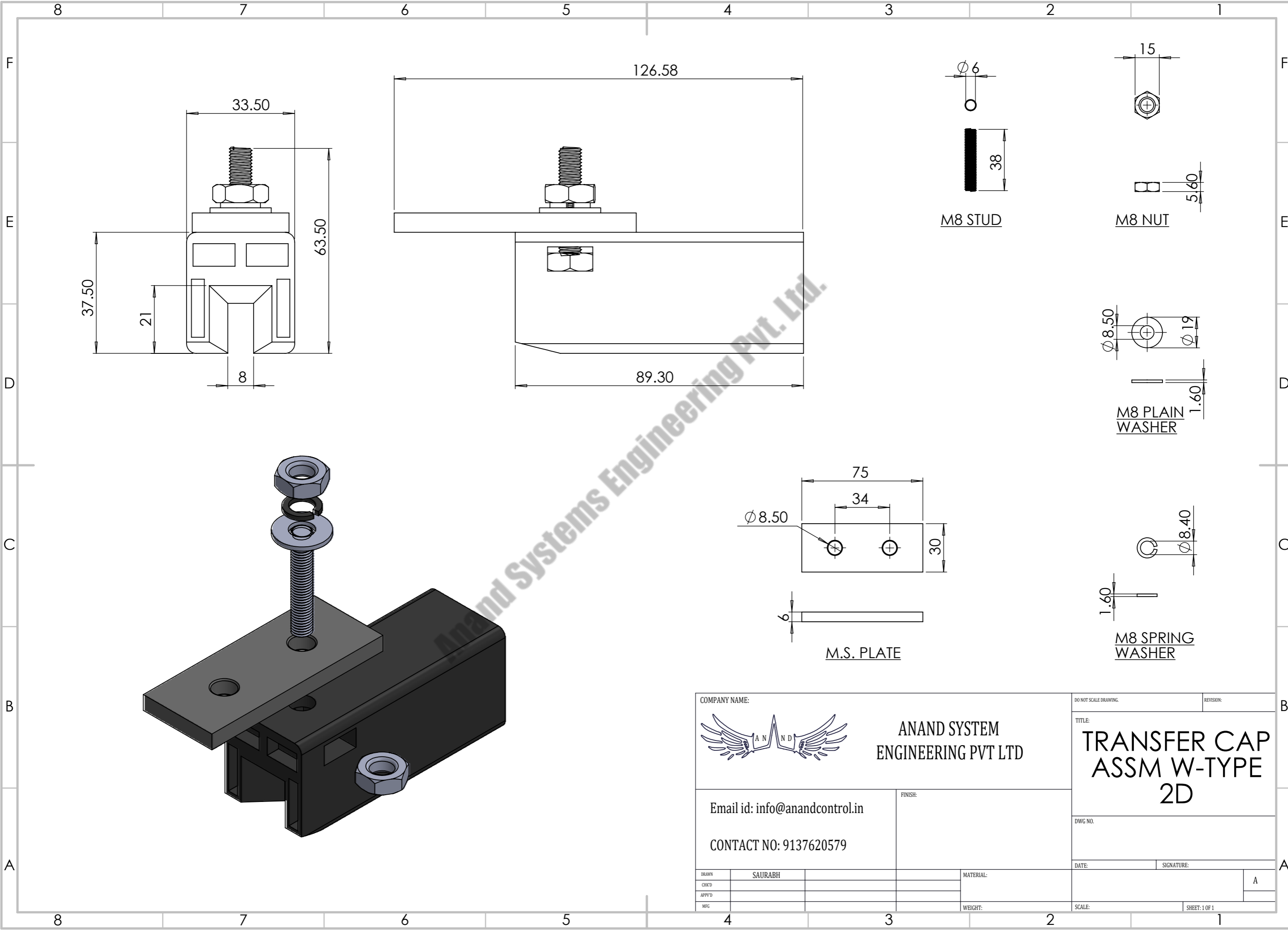

Anand System's Engineering Pvt. Ltd.

COMPANY NAME:		DO NOT SCALE DRAWING.		REVISION:	
		ANAND SYSTEM ENGINEERING PVT LTD		TITLE: SLEEVE W TYPE 2D	
Email id: info@anandcontrol.in CONTACT NO: 9137620579		FINISH:		DWG NO.	
DRAWN: SAURABH CHK'D: APP'D: MFG:		MATERIAL: WEIGHT:		DATE: SIGNATURE:	
				SCALE: SHEET: 1 OF 1	

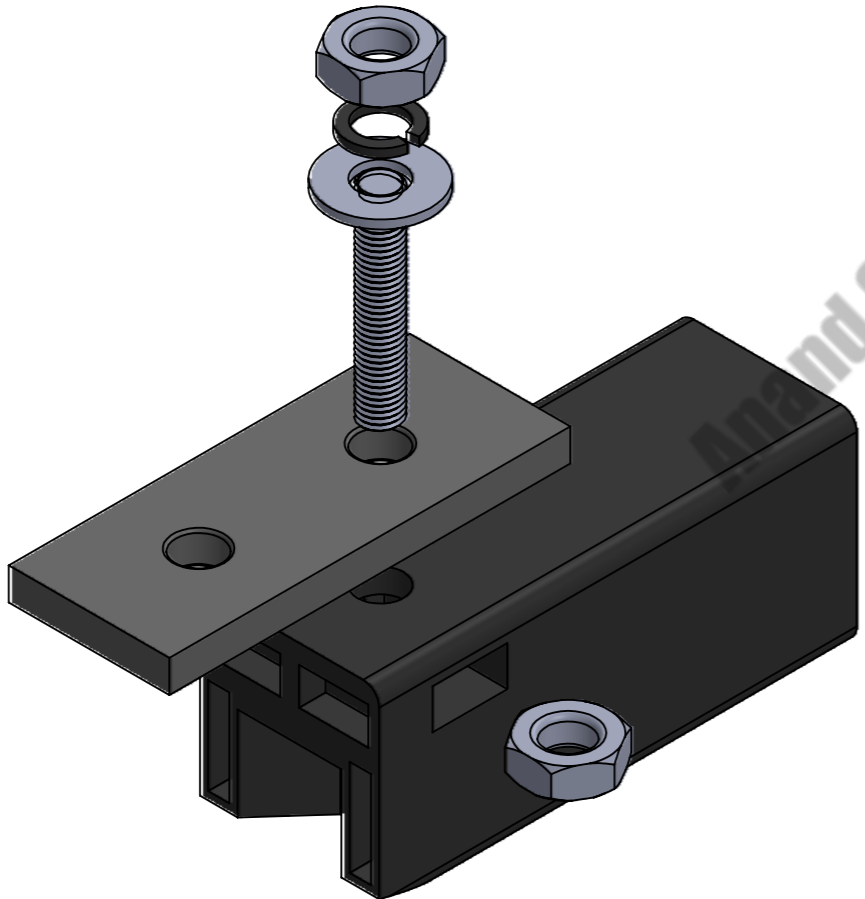

Anand Systems Engineering Pvt. Ltd.



COMPANY NAME:		DO NOT SCALE DRAWING.		REVISION:	
 ANAND SYSTEM ENGINEERING PVT LTD		TRANSFER CAP ASSM W-TYPE 2D			
		Email id: info@anandcontrol.in CONTACT NO: 9137620579		DWG NO.	
FINISH:		DATE:		SIGNATURE:	
DRAWN: SAURABH	MATERIAL:	SCALE:		A	
CHK'D:	WEIGHT:	SHEET: 1 OF 1			
APP'D:					
MFG:					

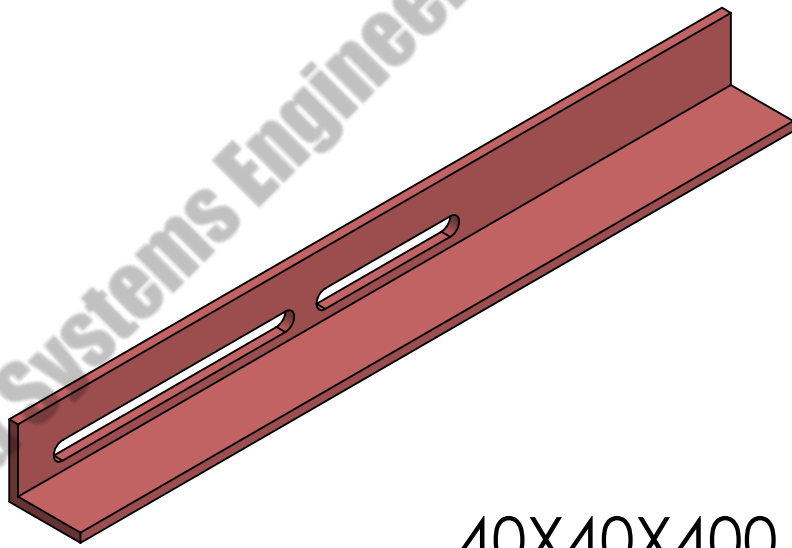
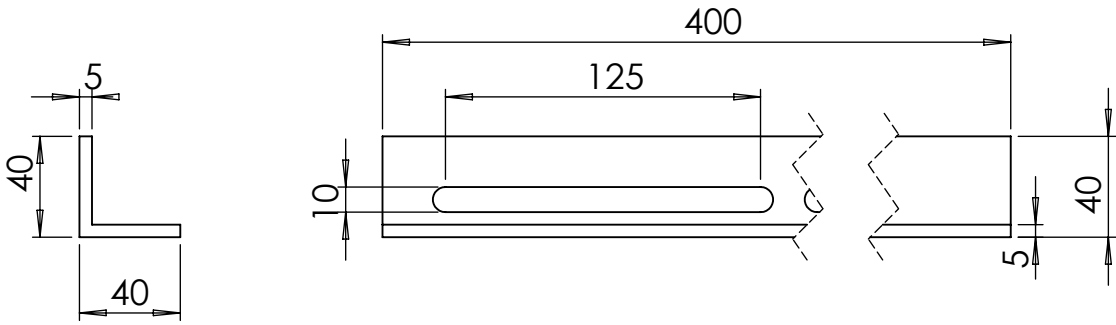

40X40X400, THK-5
MM

COMPANY NAME:		DO NOT SCALE DRAWING:		REVISION:	
 <p>ANAND SYSTEM ENGINEERING PVT LTD</p>		TITLE:			
Email id: info@anandcontrol.in		Web-Bracket 400 W TYPE 2D			
CONTACT NO: 9137620579		DWG NO.			
FINISH:		DATE:		SIGNATURE:	
DRAWN	SAURABH	MATERIAL:		A	
CHK'D		WEIGHT:			
APP'D		SCALE:		SHEET: 1 OF 1	
MFG					