

4

3

2

1

F

F

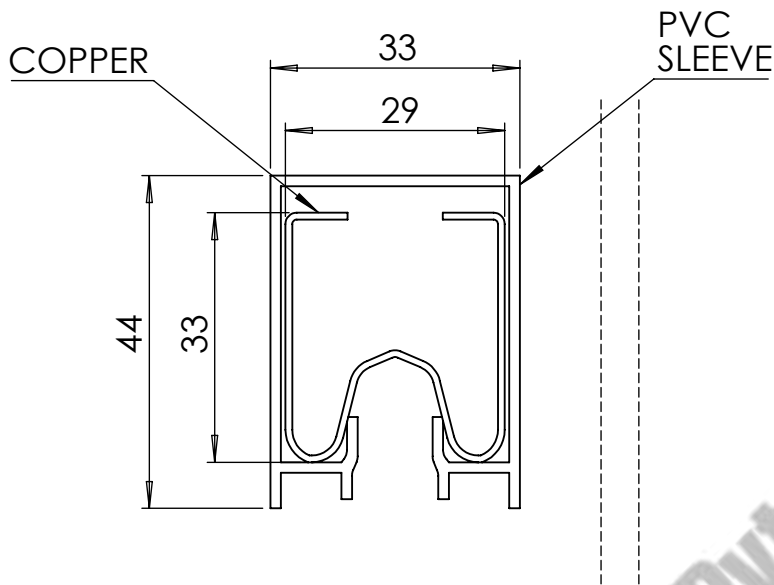

E

E

D

D

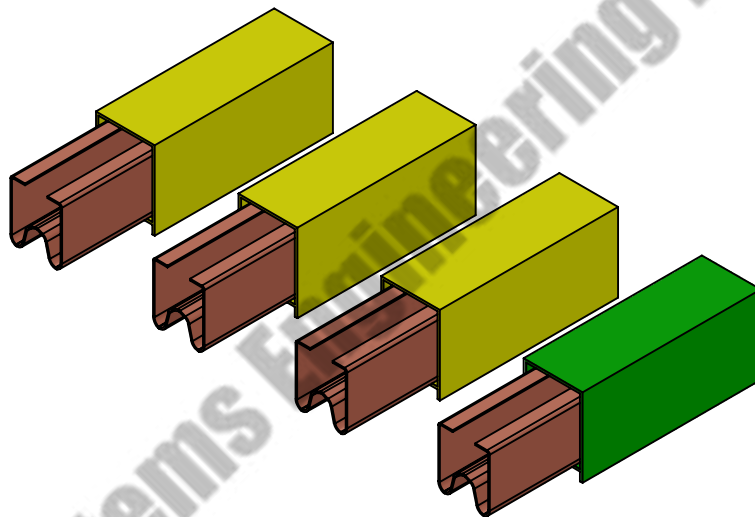

C

C

500AMP- CU- 04BAR  
 HEAVY TYPE (V)  
 YELLOW, YELLOW, YELLOW  
 GREEN-COLOUR PVC

B

B

COMPANY NAME:



ANAND SYSTEM  
 ENGINEERING PVT LTD

DO NOT SCALE DRAWING.

REVISION:

TITLE:

SAFELINK  
 500Amp YYYG  
 CU V-TYPE 2D

DWG NO.

Email id: info@anandcontrol.in

FINISH:

CONTACT NO: 9137620579

DATE:

SIGNATURE:

A

A

DRAWN	SAURABH
CHK'D	
APP'D	
MFG	

MATERIAL:

WEIGHT:

SCALE:

SHEET: 1 OF 1

4

3

2

1



ITEM NO.	PART NAME	DESCRIPTION	MATERIAL	QTY.
1	<b>WEB BRACKET V-TYPE</b>	600x40x40	M.S.	4
2	<b>CLAMP V TYPE ASSM</b>	HANGER CLAMP	DELRIN	16
	NUT	3/8"	M.S.	1
	CLAMP BOLT	M8X38	M.S.	1
	CLAMP BUSH	3/8" X 1-1/2"	DELRIN	1
	CLAMP	44.8X63X58	DELRIN	1
	M8 PLAIN WASHER	17X8.4X1.5	M.S.	1
3				
	SPRING WASHER	M8	SPRING STEEL 4454 GRADE-02	1
	<b>DSL VTYPE ASSEMBLY</b>	SAFELINK AL 500AMP	ALUMINIUM	4
4	500 Amp dsl	4500X34X28	ALUMINIUM	1
	DSL SLEEVE	4500X33X44	PLASTIC	1
	<b>JOINT CLAMP ASSEMBLY V-TYPE</b>	JOINT CLAMP	-	4
5	JOINT CLAMP PLATE	76X20, 3/8"X1/2" BOLT	M.S.	2
	JOINT CLAMP AL	35.5X48X160	ALUMINIUM	1
	HEX NUT	3/8"	M.S.	4
	PLAIN WASHER	19X10.5X1.5	M.S.	4
	SPRING WASHER	M10	SPRING STEEL 4454 GRADE-02	4
	JOINT CLAMP COVER	100X44X143	PPCP	2
	COTTER PIN 2	1/2" X 2"	M.S.	2
	<b>ANCHOR CLAMP ASSM V-TYPE</b>	ANCHOR CLAMP	-	8
6	SCREW	M8 SELF THREADED SCREW	M.S.	2
	SINGLE POLE HANGER CLAMP	65.5X40.8X62.5	DELRIN	1
7	<b>CENTRE POWER FEED ASSEMBLY</b>	-	-	4
	JOINT CLAMP PLATE	76X20, 3/8"X1/2" BOLT	M.S.	2
	JOINT CLAMP AL	35.5X48X160	ALUMINIUM	1
	HEX NUT	3/8"	M.S.	4
	PLAIN WASHER	19X10.5X1.5	M.S.	4
	SPRING WASHER	M10	SPRING STEEL 4454 GRADE-2	4
	CENTRE POWER FEED COVER	100X44X143	PPCP	2
	COTTER PIN 2	1/2" X 2"	M.S.	2
	<b>EXPANSION JOINT ASSEMBLY V-TYPE</b>	321X80X30	-	4
	8	EXPANSION JOINT CLAMP	35.5X48X250	ALUMINIUM
COPPER SLEEVE		20X20	COPPER	4
COPPER SLEEVE 2		20X59	COPPER	2
PLAIN WASHER		19X10.5X1.5	M.S.	8
COPPER COIL FLAT 2		1mm THICKNESS	COPPER	2
EXPANSION JOINT COVER		100X44X143	PPCP	2
EXPANSION JOINT CLAMP PLATE		76X20, 2 M8 BOLT	M.S.	3
COPPER COIL FLAT 1		1mm THK	COPPER	2
GRUMET		GRUMET 1"	RUBBER	2
COTTER PIN 2		1/2" X 2"	M.S.	2
NUT		3/8"	M.S.	6
9		<b>END COVER V TYPE ASSM</b>	-	-
	ALENKEY BOLT	M6X50	M.S.	1
	BRASS BUSH	30X Ø8	BRASS	1
	END COVER	37.5X49.5X139	PPCP	1
	<b>PARALLEL CURRENT COLLECTOR 250 AMP</b>	-	-	4
	ARM	220X16X3	ALUMINIUM	4
	LOWER BRACKET 2	73X56X30	M.S.	2
	LOWER PIN	M8X75	M.S.	2
	PLAIN WASHER	11X5.5X1.5	M.S.	16
	SHOE	186.5X56X3	CARBON	2
10	SHOE HOLDER	200X64X19	PLASTIC	4
	SPRING	TENSION SPRING	SPRING STEEL 4454 GRADE-02	2
	VERTICAL LEVER	61X50X24	M.S.	2
	VERTICAL STUD	16X110	M.S.	2
	VERTICAL STUD PIN	8X22	M.S.	2
	SPACER PIN	40X6	ALUMINIUM	8
	HEX BOLT	M8, 8X20, END COVER FIXING	M.S.	2
	HEX NUT	3/8"	M.S.	2
	PLAIN WASHER	19X10.5X1.5	M.S.	2
	E CIRCLIP	M7X25	SPRING STEEL 4454 GRADE-02	2
	COTTER PIN	1/8"X 3/4"	M.S.	8
	HEX BOLT	M5X20	M.S.	4
HEX NUT	M5	M.S.	12	
STAR SCREW	M4X6.5	M.S.	12	
WIRE TIE CLIP	CABLE CLAMP	PLASTIC	4	
CABLE LUG	25 SQ MM	COPPER	4	
CABLE 1	25 SQ mm	COPPER	1	
CABLE 2	25 SQ mm	COPPER	1	
CABLE 3	25 SQ mm	COPPER	1	
CABLE 4	25 SQ mm	COPPER	1	
10	<b>CC TOWING BRACKET V-TYPE</b>	103X103, L-500	M.S.	1

# EXPLODED VIEW

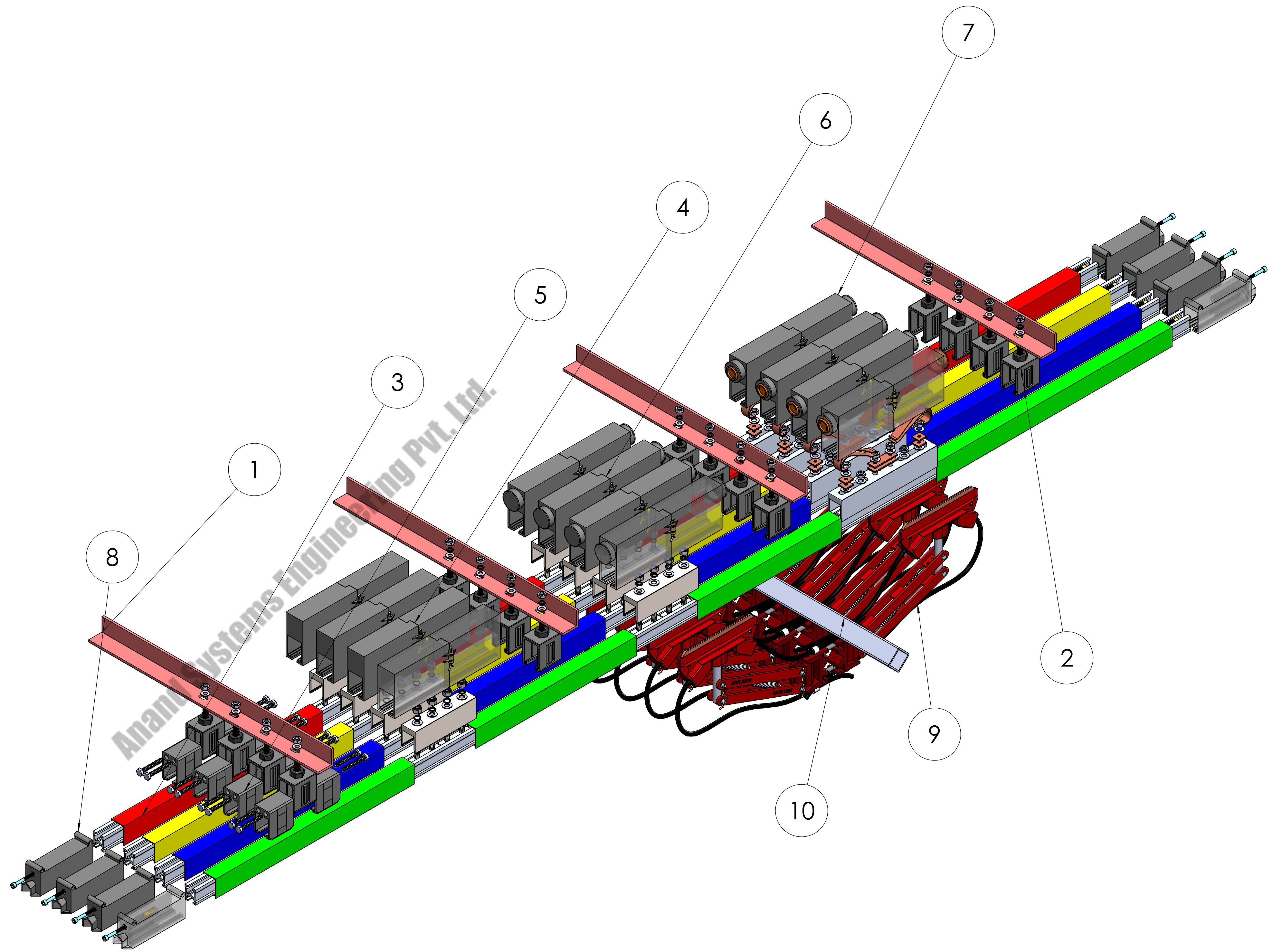

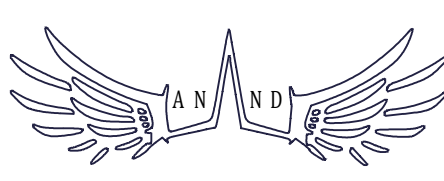
COMPANY NAME:		ANAND SYSTEM ENGINEERING PVT LTD		DO NOT SCALE DRAWING	REVISION
		<b>ANAND SYSTEM ENGINEERING PVT LTD</b>		TITLE: V-TYPE DSL BUSBAR ASSEMBLY 2D	
Email id: info@anandcontrol.in		FENISE:		DWG. NO.	
CONTACT NO: 9137620579				DATE: 18-12-2024 SIGNATURE:	
DRWN: SAURABH	CHKD: AJAY	MATERIAL:	A		
APPD:		WEIGHT:	SCALE: SHEET: 1 OF 1		



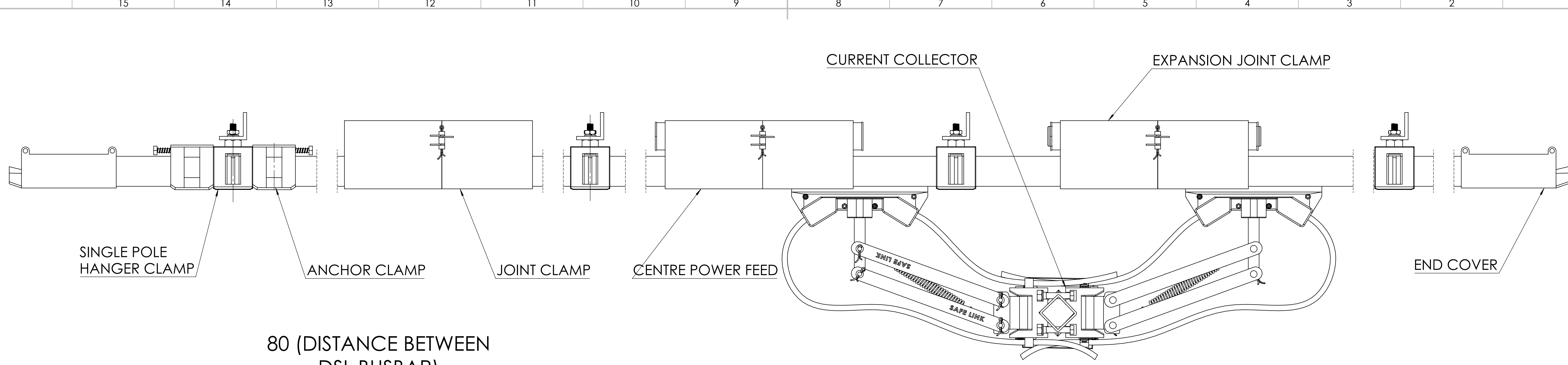

80 (DISTANCE BETWEEN DSL BUSBAR)

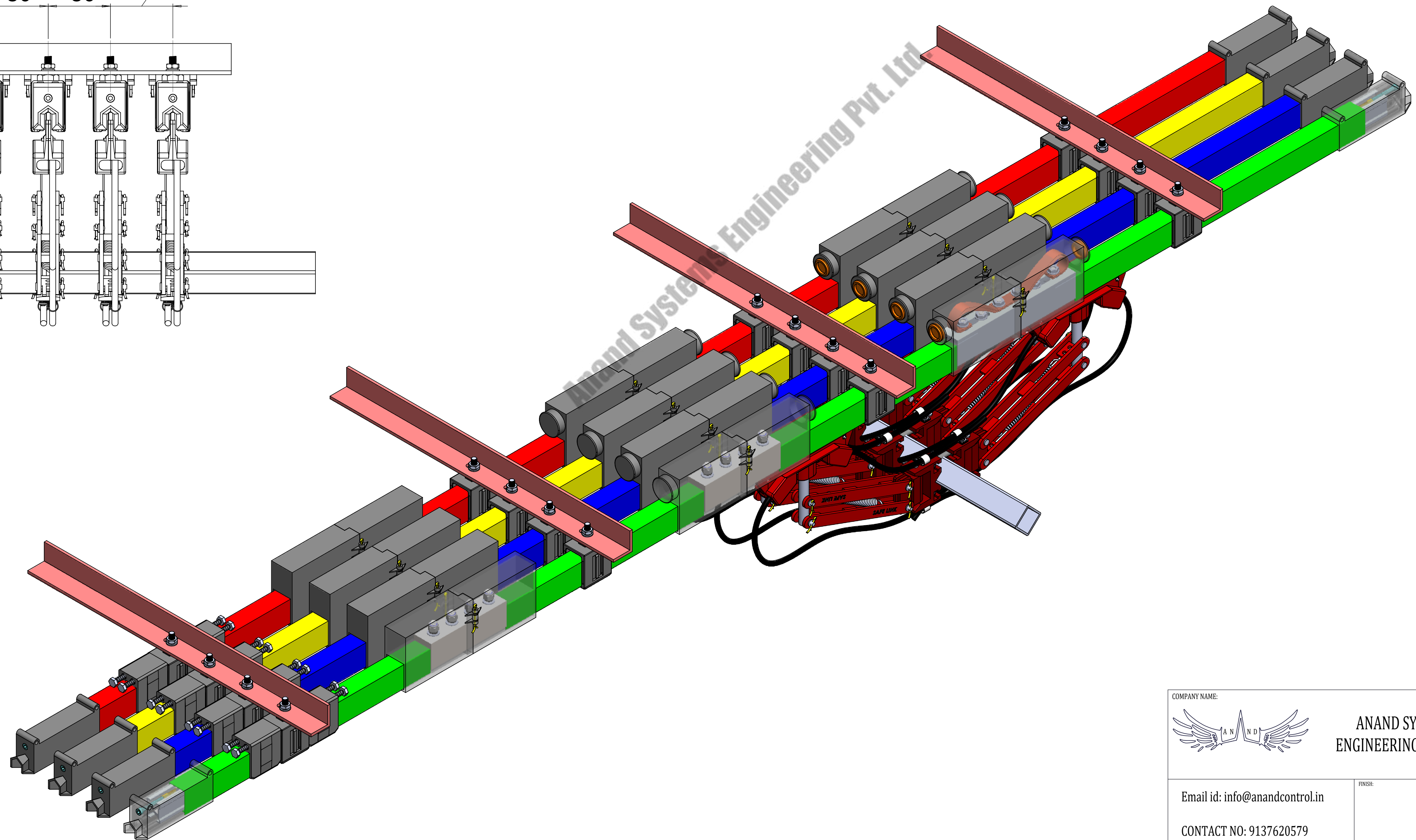
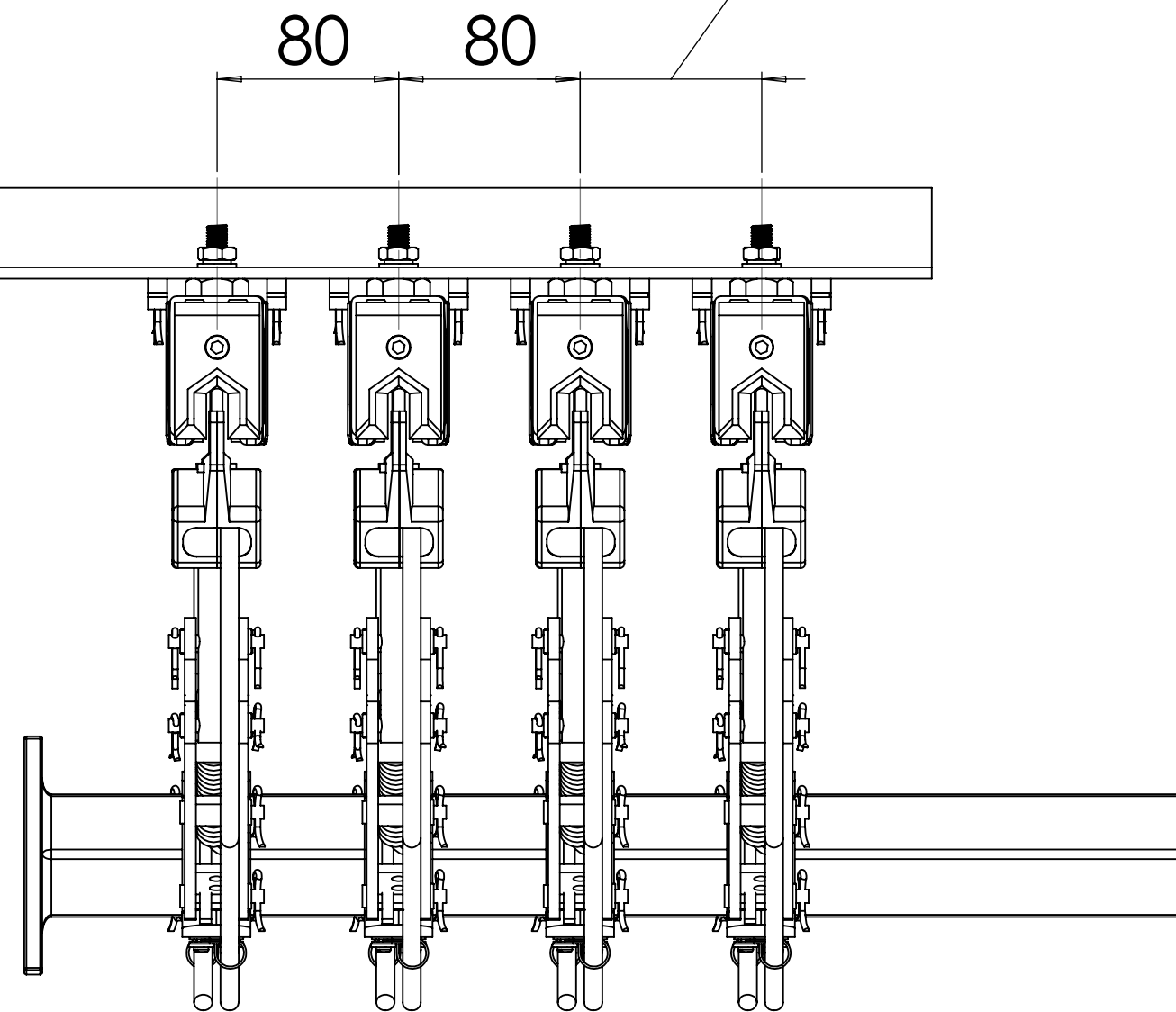

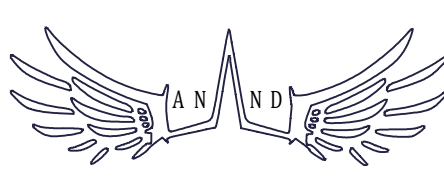
COMPANY NAME:		ANAND SYSTEM ENGINEERING PVT LTD		DO NOT SCALE DRAWING	REVISION:
		Email id: info@anandcontrol.in CONTACT NO: 9137620579		TITLE: <b>V-TYPE DSL BUSBAR ASSEMBLY 2D</b>	
DATE: 18-12-2024	SIGNATURE:	SCALE:		SHEET: 1 OF 1	
DRWN: SAURABH	CKCD: AJAY	APPRD:	MATERIAL:	A	
WGT:	WEIGHT:				

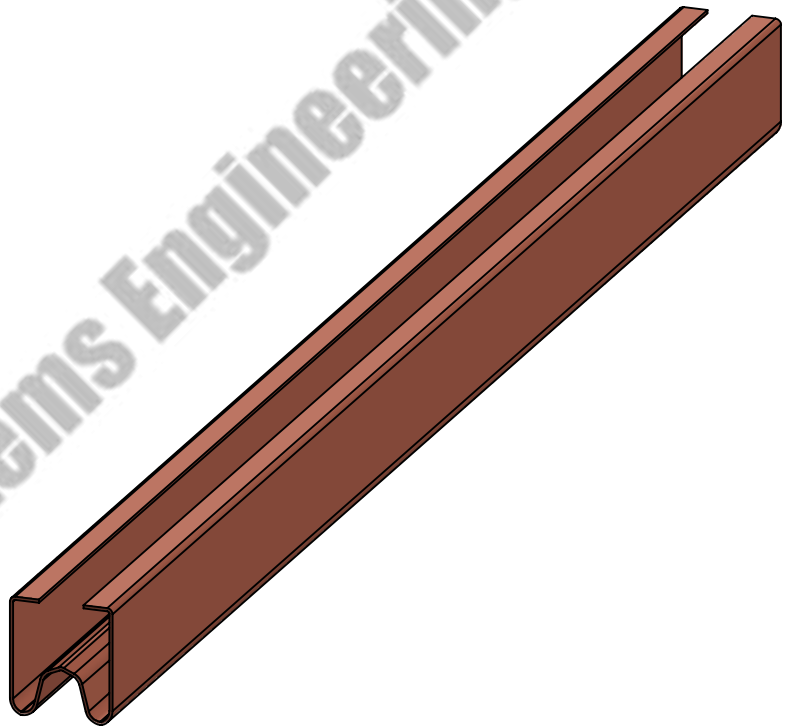
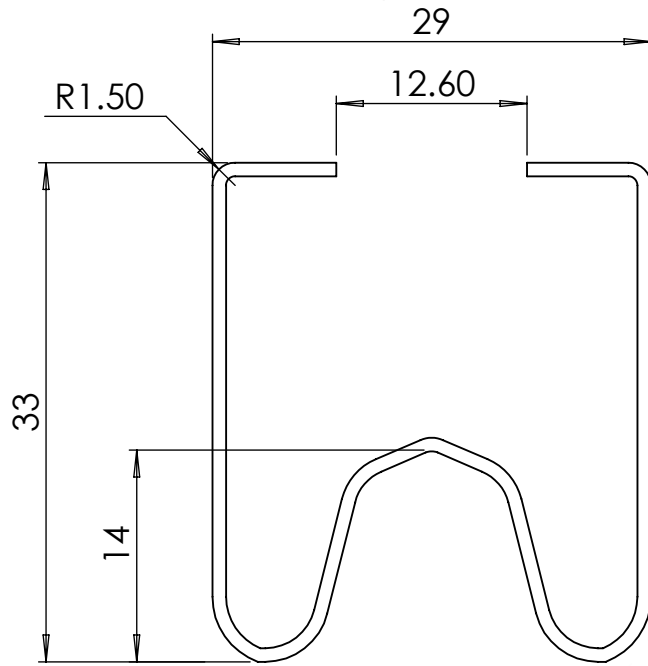

COMPANY NAME:



**ANAND SYSTEM  
ENGINEERING PVT LTD**

DO NOT SCALE DRAWING.

REVISION:

TITLE:

**DSL BUSBAR  
COPPER V  
TYPE 2D**

Email id: info@anandcontrol.in

CONTACT NO: 9137620579

FINISH:

DWG NO.

DATE:

SIGNATURE:

DRAWN	SAURABH
CHK'D	
APP'D	
MFG	

MATERIAL:

WEIGHT:

SCALE:

SHEET: 1 OF 1

A

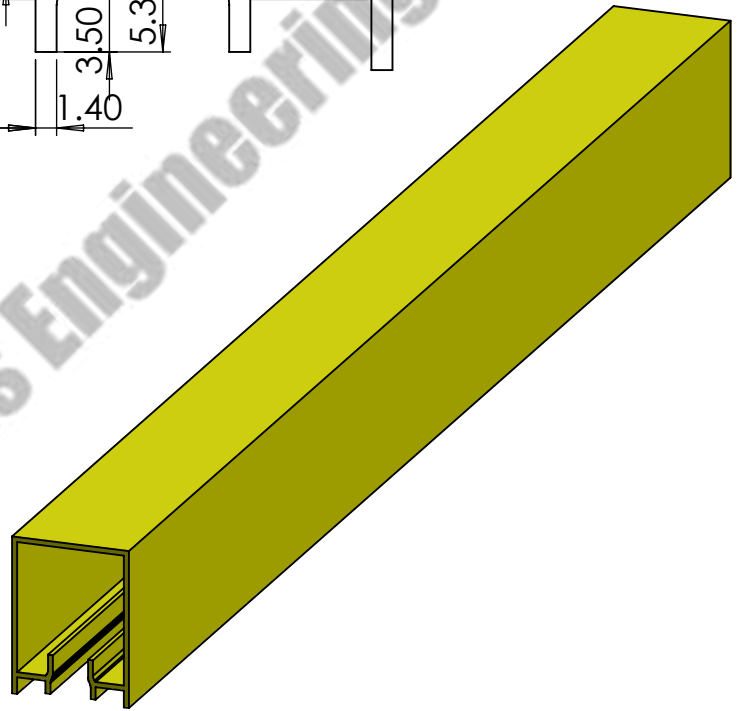
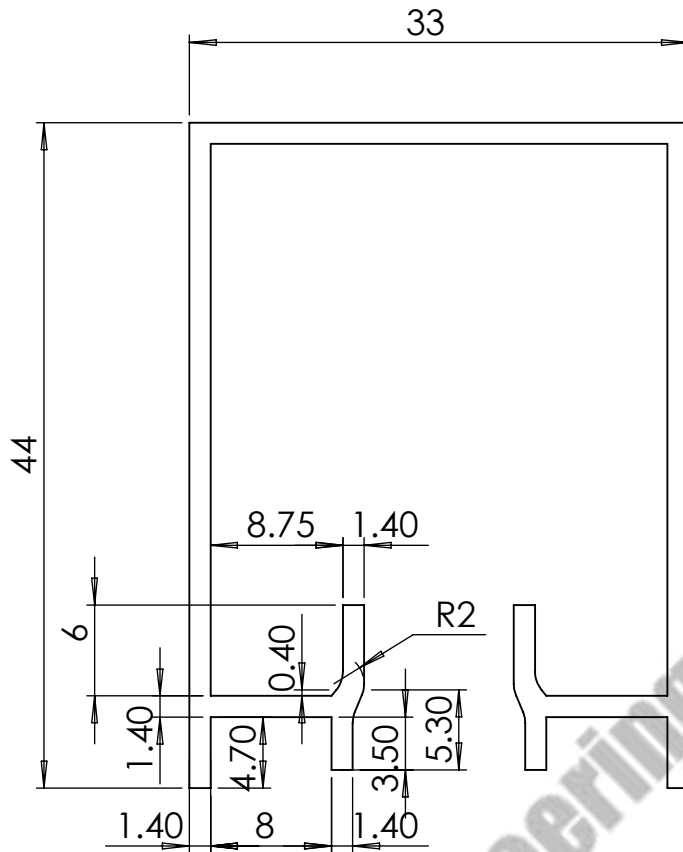

COMPANY NAME:



**ANAND SYSTEM  
ENGINEERING PVT LTD**

Email id: [info@anandcontrol.in](mailto:info@anandcontrol.in)

CONTACT NO: 9137620579

FINISH:

DO NOT SCALE DRAWING.

REVISION:

TITLE:

**V TYPE DSL  
SLEEVE 2D**

DWG NO.

DATE:

SIGNATURE:

DRAWN	SAURABH
CHK'D	
APP'D	
MFG	

MATERIAL:

WEIGHT:

SCALE:

SHEET: 1 OF 1

A

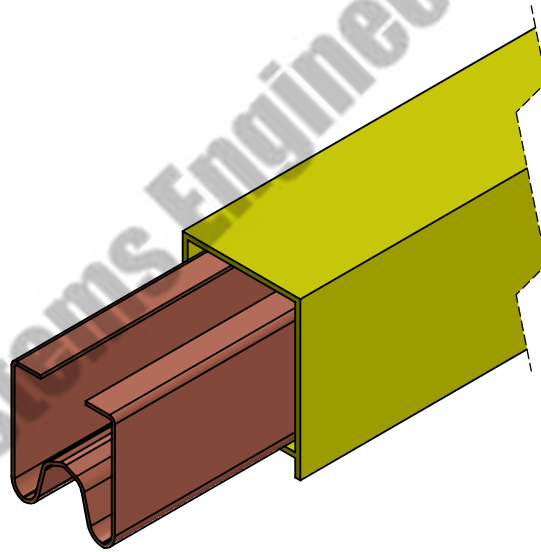
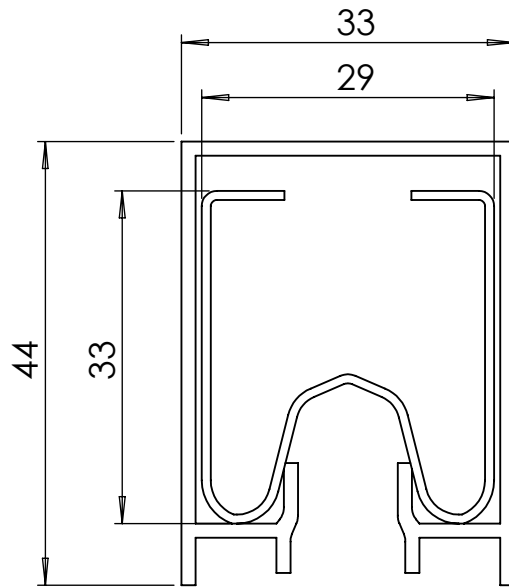

COMPANY NAME:



**ANAND SYSTEM  
ENGINEERING PVT LTD**

DO NOT SCALE DRAWING.

REVISION:

TITLE:

**DSL COPPER  
BUSBAR V TYPE  
ASSM 2D**

Email id: info@anandcontrol.in

CONTACT NO: 9137620579

FINISH:

DWG NO.

DATE:

SIGNATURE:

DRAWN	SAURABH
CHK'D	
APP'D	
MFG	

MATERIAL:  
**COPPER**

A

WEIGHT:

SCALE:

SHEET: 1 OF 1



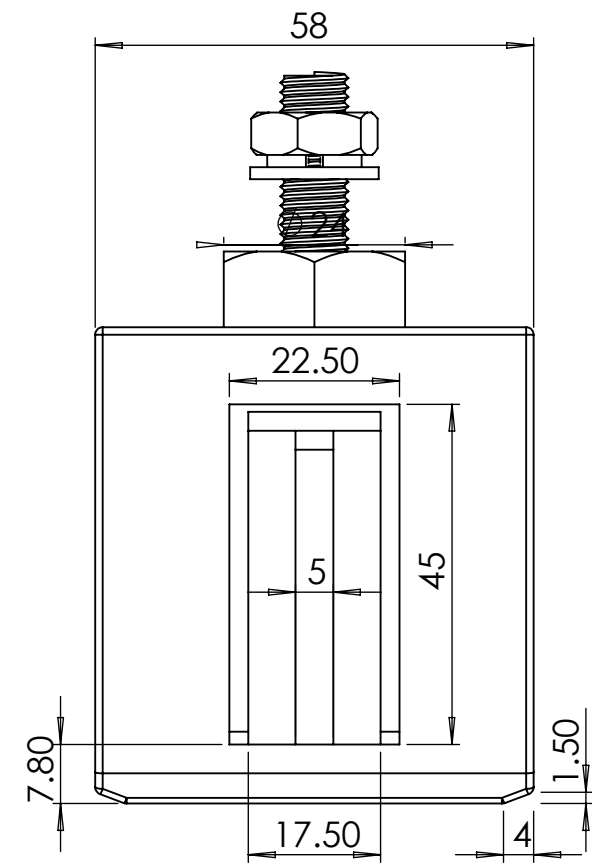
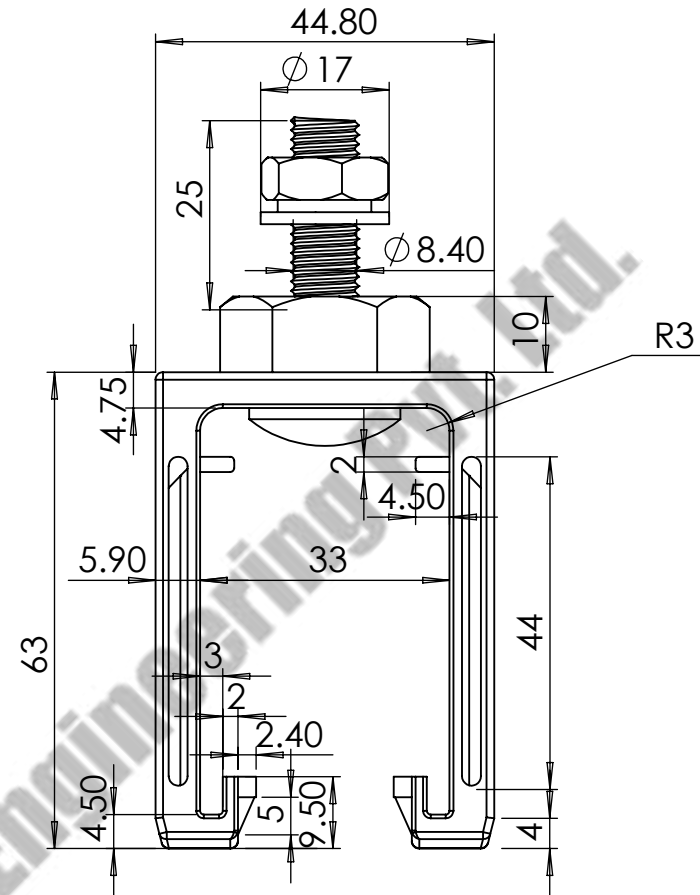
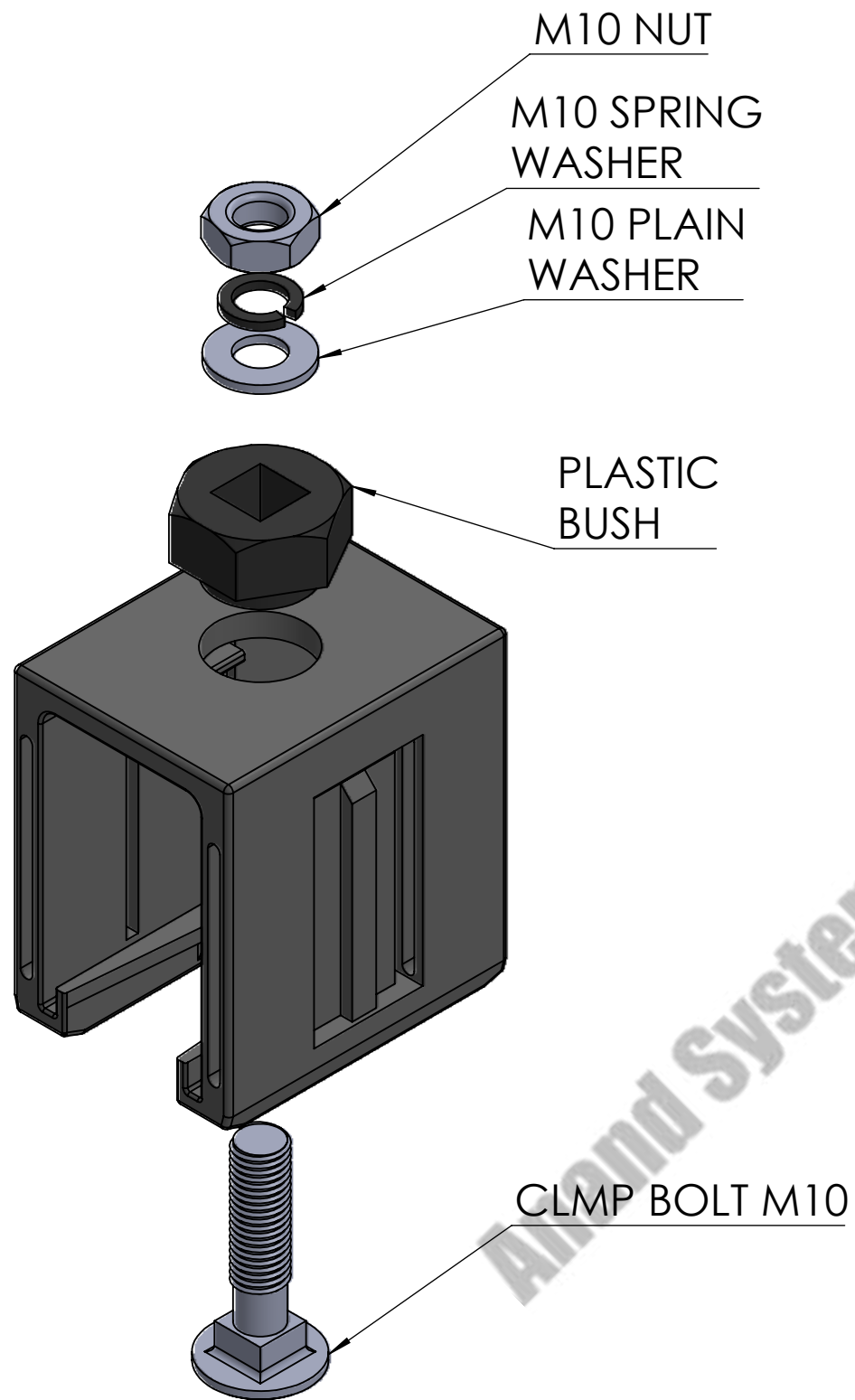

COMPANY NAME:		ANAND SYSTEM ENGINEERING PVT LTD		DO NOT SCALE DRAWING.	REVISION:
		Email id: info@anandcontrol.in CONTACT NO: 9137620579		TITLE: SINGLE POLE HANGER CLAMP V TYPE ASSM 2D	
DRAWN: SAURABH		FINISH:		DATE:	
CHK'D:		MATERIAL:		SIGNATURE:	
APP'D:		WEIGHT:		SCALE:	
MFC:		SHEET: 1 OF 1		A	

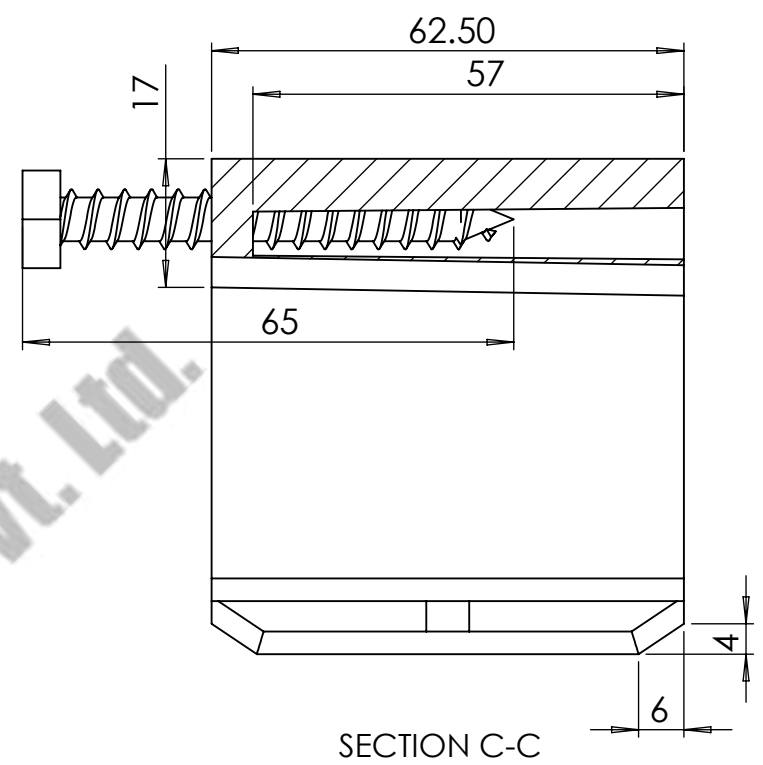
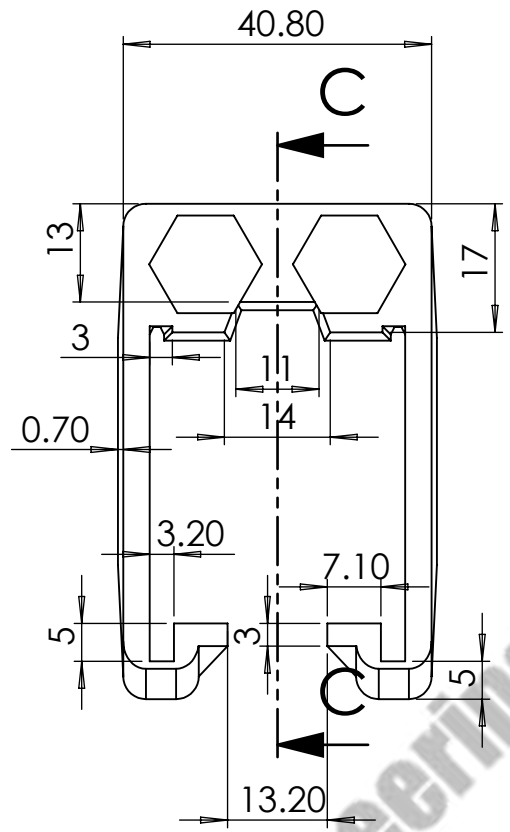
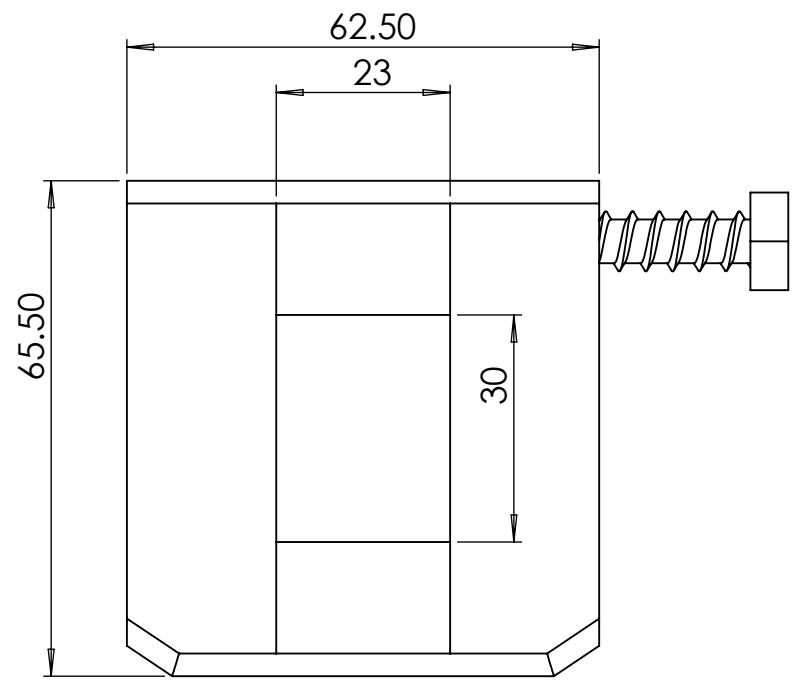

M8 SELF  
THREADED  
SCREW

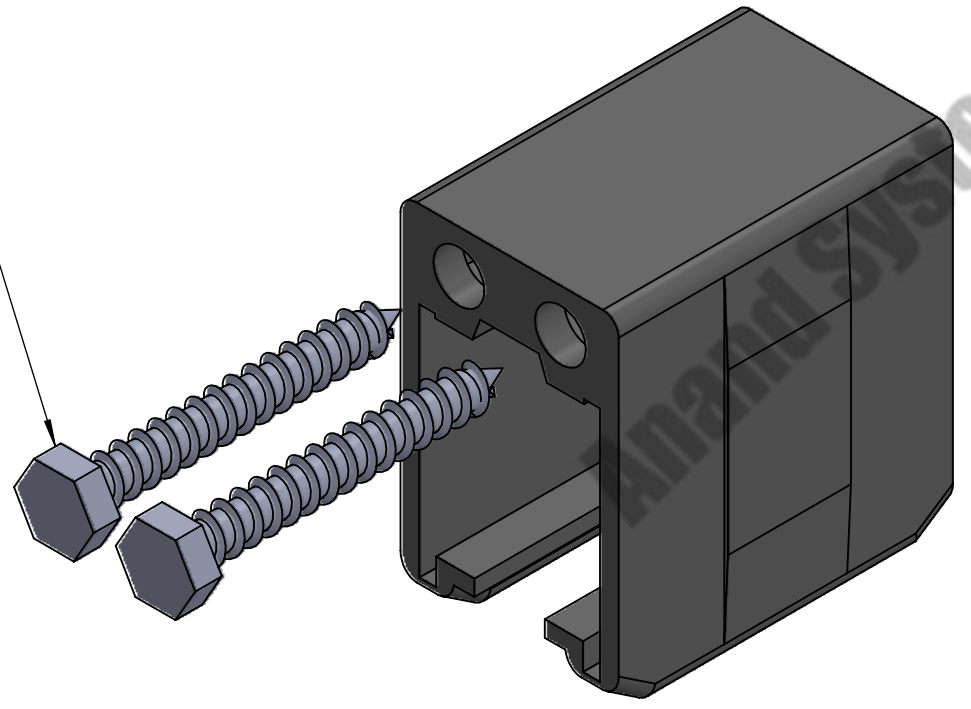

COMPANY NAME:		ANAND SYSTEM ENGINEERING PVT LTD		DO NOT SCALE DRAWING.	REVISION:
Email id: info@anandcontrol.in		FINISH:		TITLE: ANCHOR CLAMP ASSM V-TYPE 2D	
CONTACT NO: 9137620579		MATERIAL:		DWG NO.	
DRAWN	SAURABH			DATE:	SIGNATURE:
CHK'D					
APP'VD					
MFG				SCALE:	SHEET: 1 OF 1
				A	



8 7 6 5 4 3 2 1

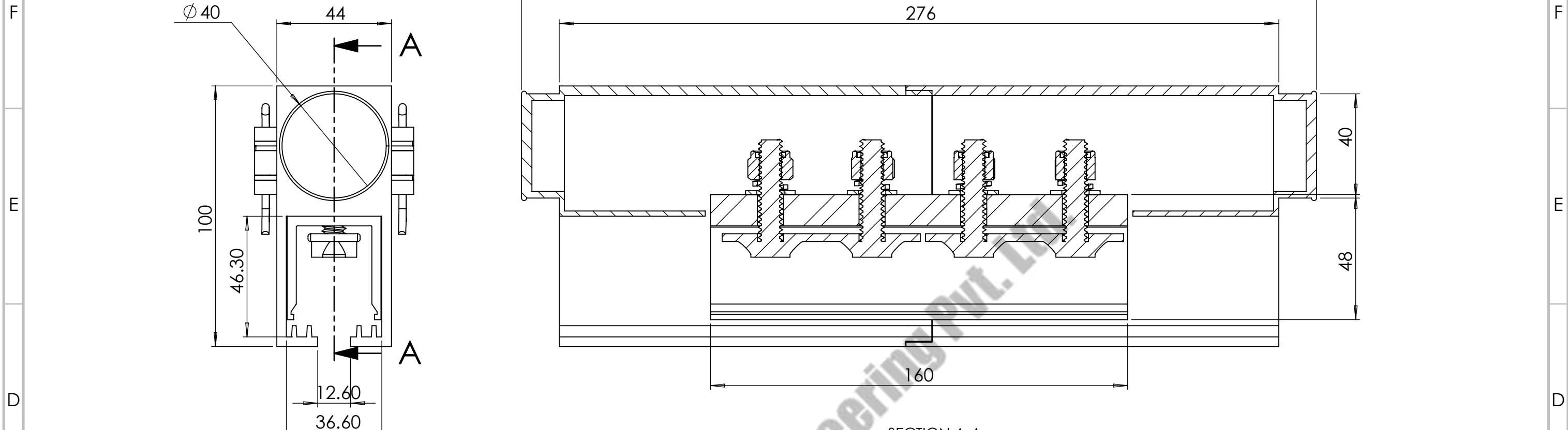

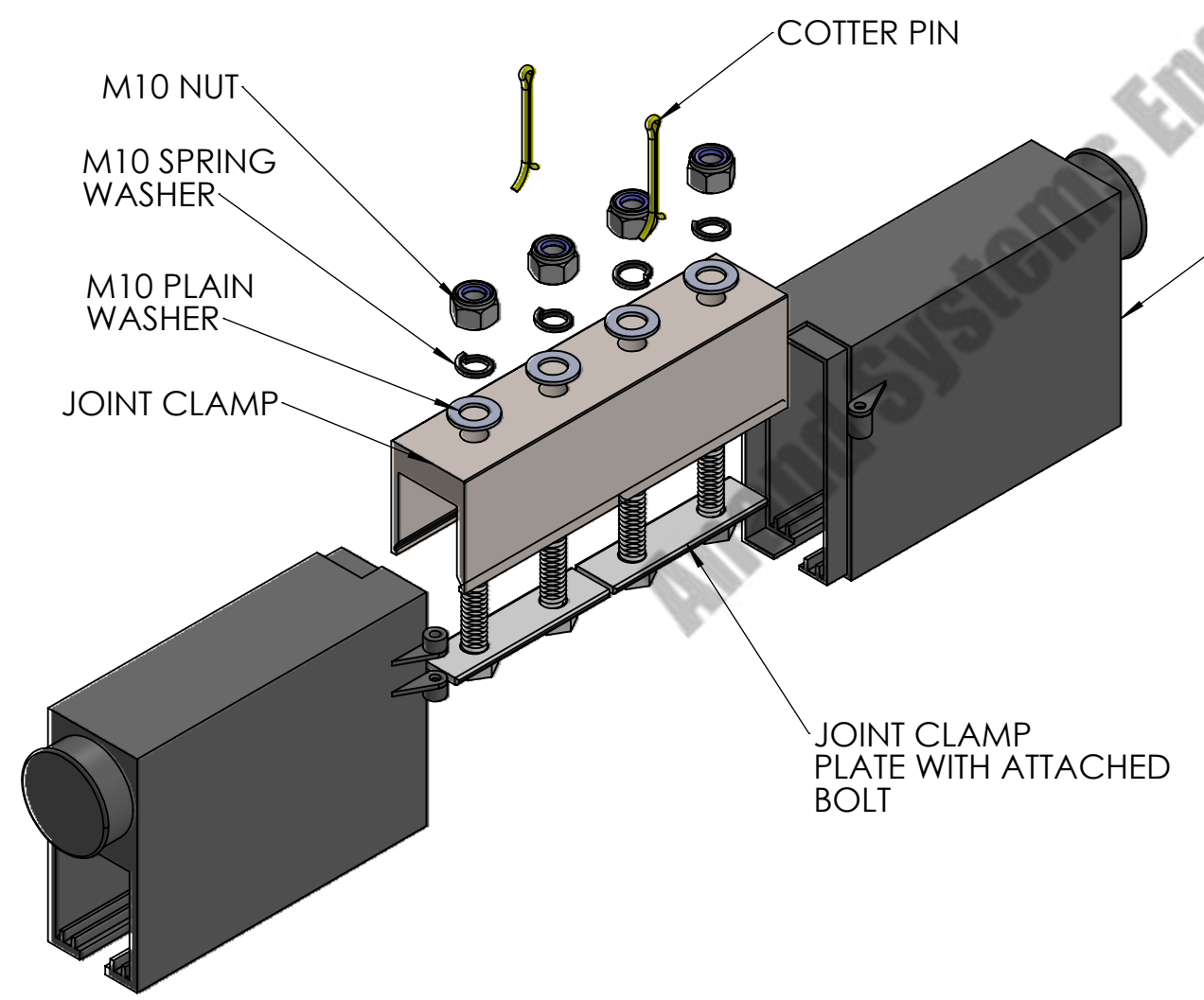

SECTION A-A  
SCALE 1 : 1.5

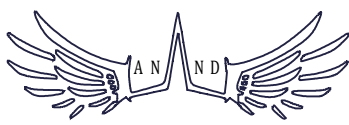

COMPANY NAME:		ANAND SYSTEM ENGINEERING PVT LTD		DO NOT SCALE DRAWING.	REVISION:
		Email id: info@anandcontrol.in CONTACT NO: 9137620579		TITLE: <b>CENTRE POWER FEED ASSEMBLY V-TYPE 2D</b>	
FINISH:		DATE:		SIGNATURE:	
DRAWN	SAURABH	MATERIAL:		A	
CHK'D		WEIGHT:		SCALE:	
APPY'D		SCALE:		SHEET: 1 OF 1	
MFC		SCALE:		SHEET: 1 OF 1	

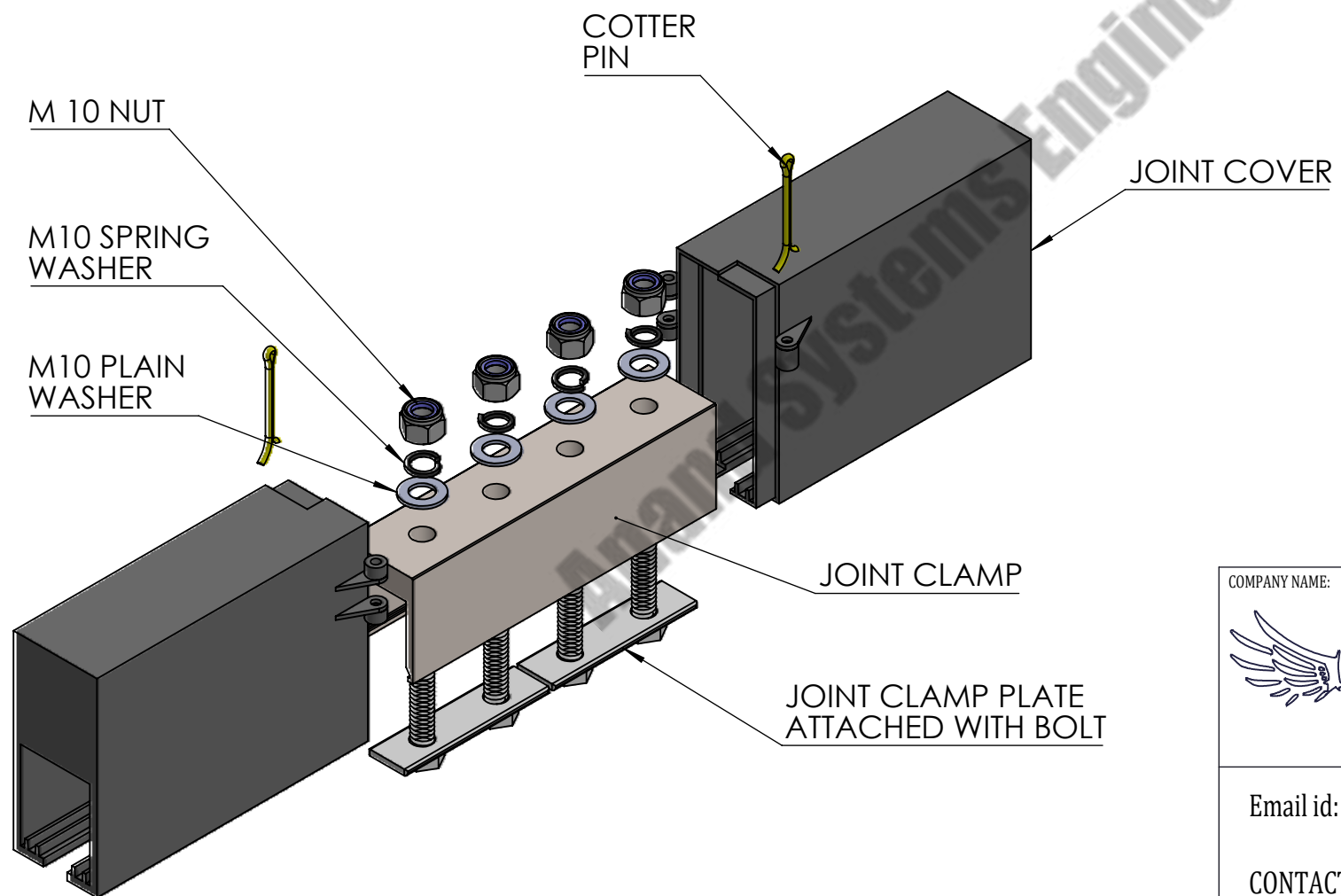
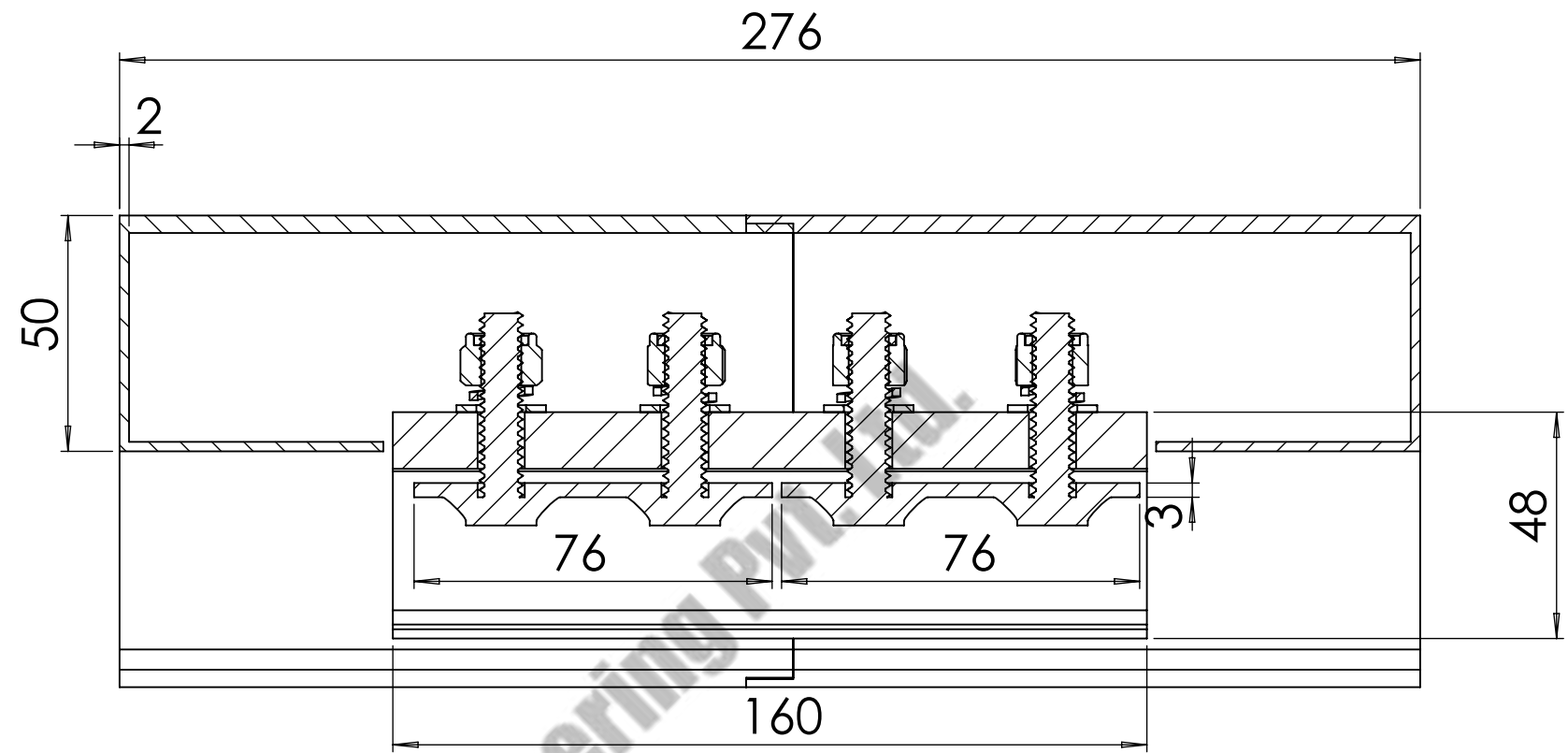
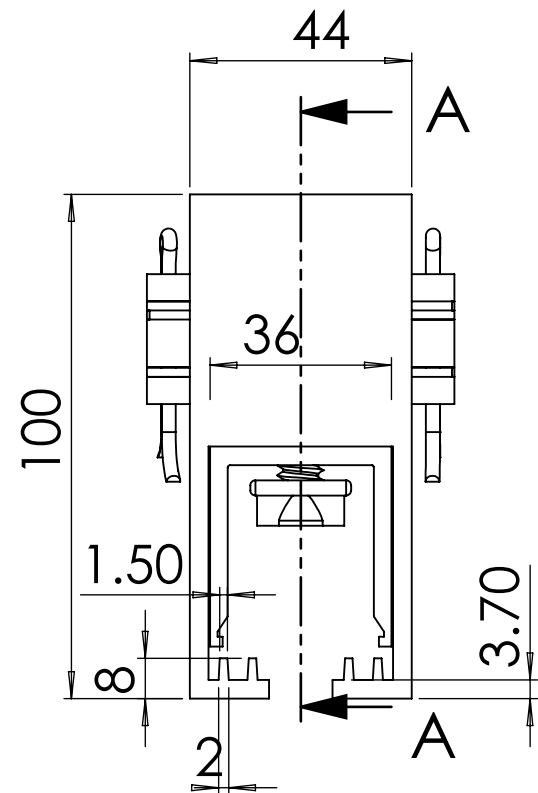
8 7 6 5 4 3 2 1



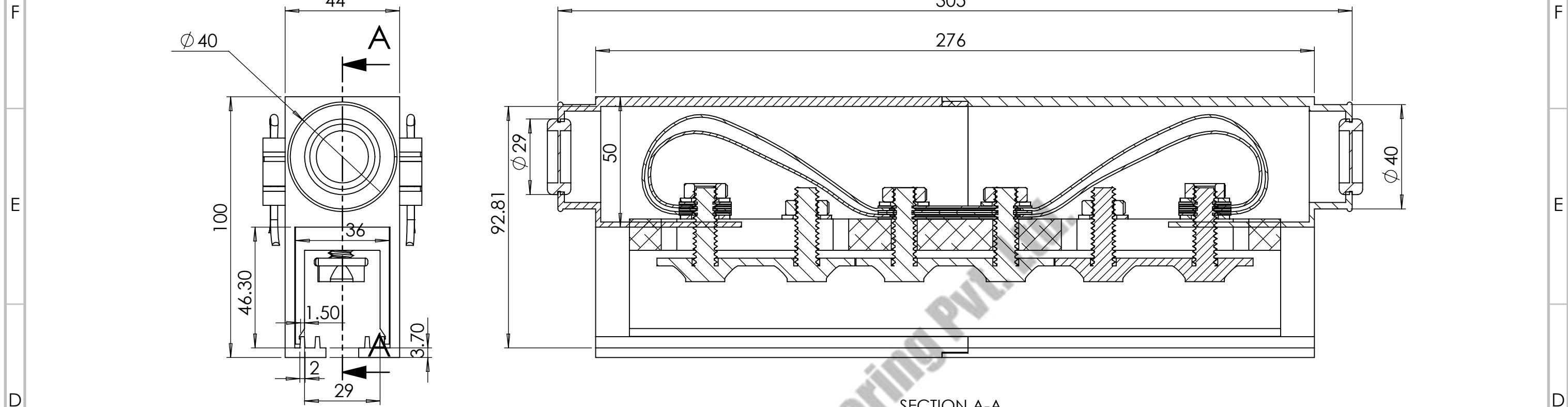

COMPANY NAME:		ANAND SYSTEM ENGINEERING PVT LTD		DO NOT SCALE DRAWING.	REVISION:
		Email id: info@anandcontrol.in CONTACT NO: 9137620579		TITLE: <b>JOINT CLAMP ASSEMBLY V-TYPE 2D</b>	
FINISH:		DATE:		SIGNATURE:	
DRAWN	SAURABH	MATERIAL:	A		
CHK'D		WEIGHT:	SCALE:		
APP'D		SHEET: 1 OF 1			
MFG					

8 7 6 5 4 3 2 1

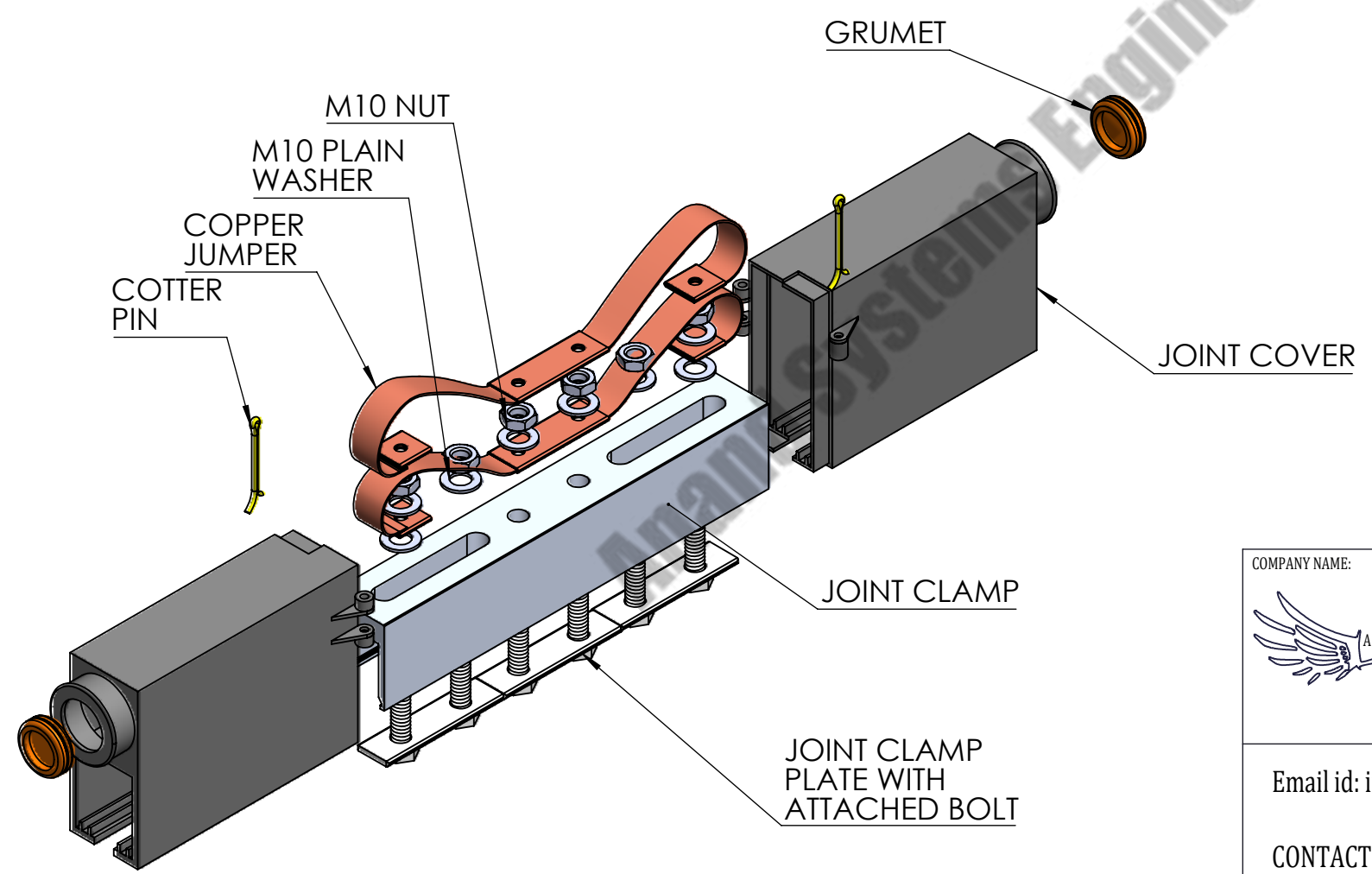

SECTION A-A  
SCALE 1 : 1.5



COMPANY NAME:		ANAND SYSTEM ENGINEERING PVT LTD		DO NOT SCALE DRAWING.	REVISION:
		Email id: info@anandcontrol.in		TITLE: EXPANSION JOINT ASSEMBLY V-TYPE 2D	
		CONTACT NO: 9137620579		DWG NO.	
DRAWN: SAURABH		FINISH:		DATE:	SIGNATURE:
CHK'D:		MATERIAL:		A	
APP'D:		WEIGHT:		SCALE:	
MFG:				SHEET: 1 OF 1	

8 7 6 5 4 3 2 1



# EXPLODED VIEW

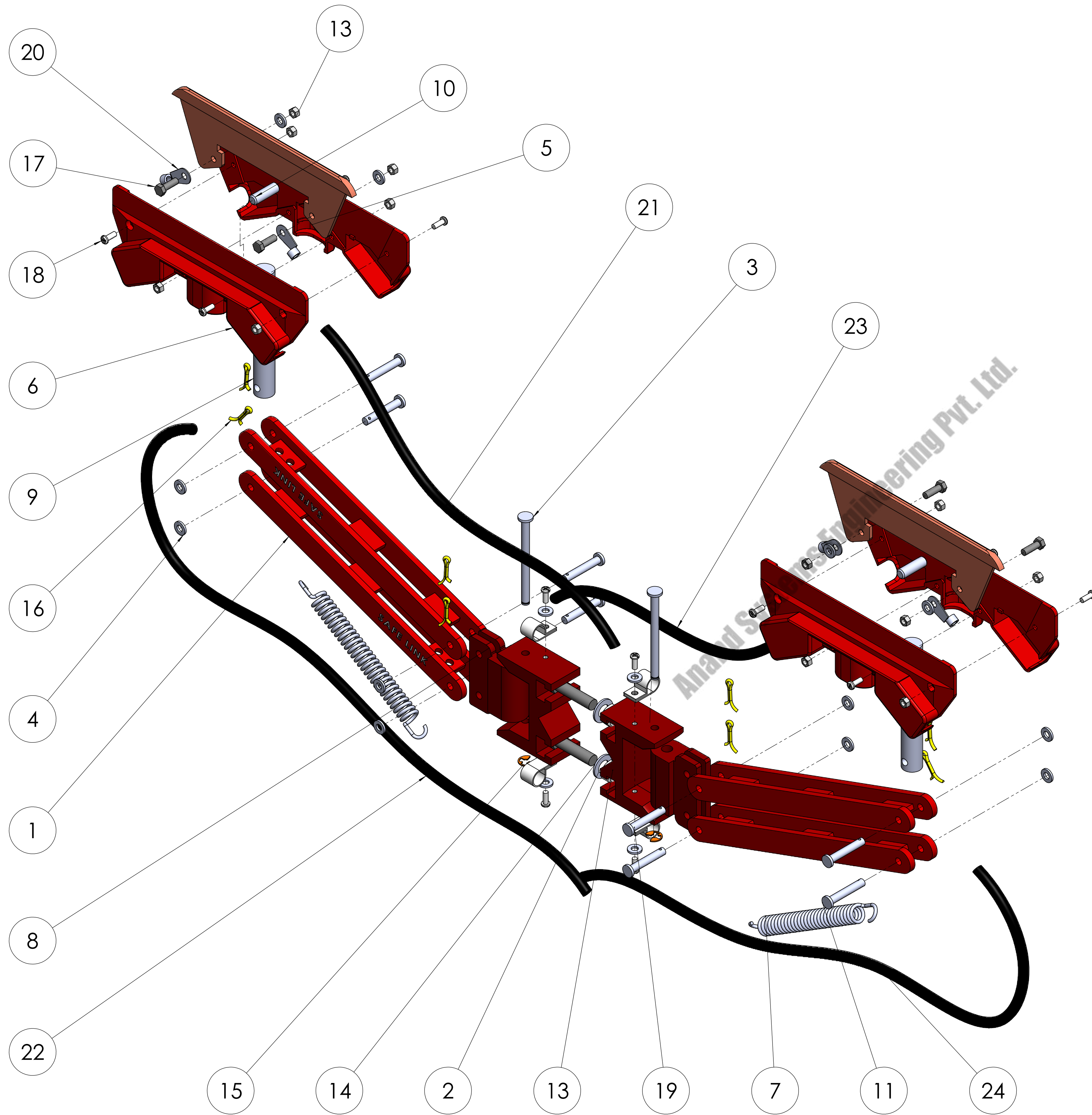

ITEM NO.	PART NAME	DESCRIPTION	Material	QTY.
1	ARM	245X19X3	ALUMINIUM	4
2	LOWER BRACKET 2	73X56X30	M.S.	2
3	PIN 16X70	16X70	M.S.	2
4	PLAIN WASHER	11X5.5X1.5	M.S.	16
5	SHOE	186.5X56X3	CARBON	2
6	SHOE HOLDER	200X64X19	PLASTIC	4
7	SPRING	TENSION SPRING	SPRING STEEL 4454 GRADE-2	2
8	VERTICAL LEVER	61X50X24	M.S.	2
9	VERTICAL STUD	16X110	M.S.	2
10	VERTICAL STUD PIN	8X22	M.S.	2
11	SPACER PIN	40X6	ALUMINIUM	8
12	HEX BOLT	M8, 8X20, END COVER FIXING	M.S.	2
13	HEX NUT	3/8"	M.S.	14
14	PLAIN WASHER	19X10.5X1.5	M.S.	2
15	E CIRCLIP	7X25	SPRING STEEL 4454 GRADE-2	2
16	COTTER PIN	1/8"X 3/4"	M.S.	8
17	HEX BOLT	5X20	M.S.	4
18	STAR SCREW	M4X6.5	M.S.	12
19	WIRE TIE CLIP	CABLE CLAMP	PLASTIC	4
20	CABLE LUG	6MM	COPPER	4
21	CABLE 1	25 SQ mm		1
22	CABLE 2	25 SQ mm		1
23	CABLE 3	25 SQ mm		1
24	CABLE 4	25 SQ mm		1

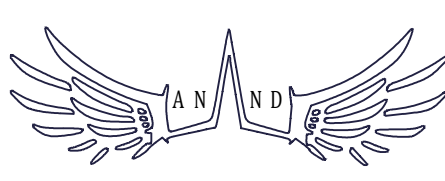
COMPANY NAME:  <b>ANAND SYSTEM ENGINEERING PVT LTD</b>		DO NOT SCALE DRAWING REVISION:
Email id: info@anandcontrol.in CONTACT NO: 9137620579		TITLE: <b>CURRENT COLLECTOR 500AMP 2D</b>
DRAWN: SAURABH CHECKED: APPROVED: MFC:	FINISH: WEIGHT:	DWG. NO.: DATE: SIGNATURE:
SCALE:		SHEET: 1 OF 1



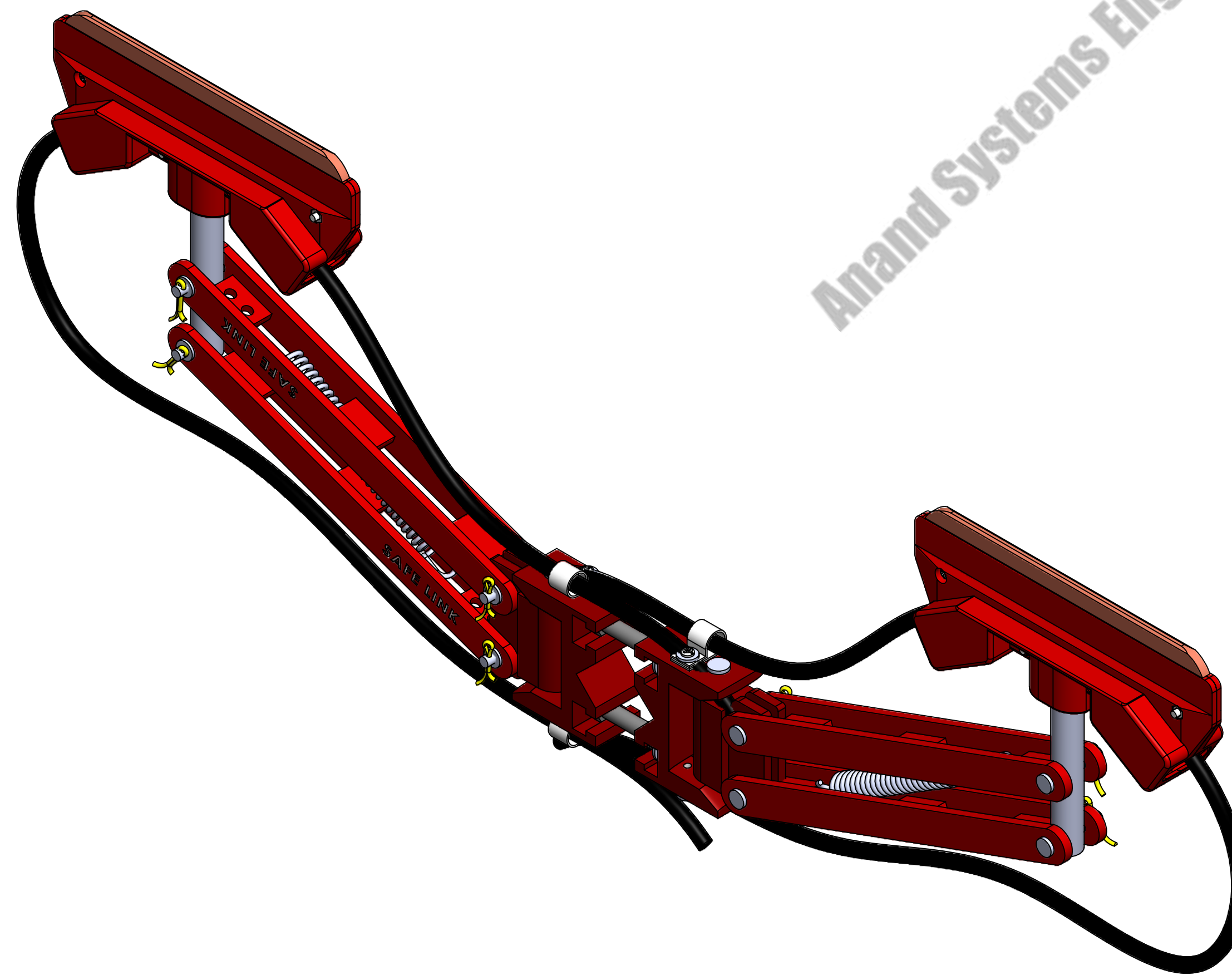
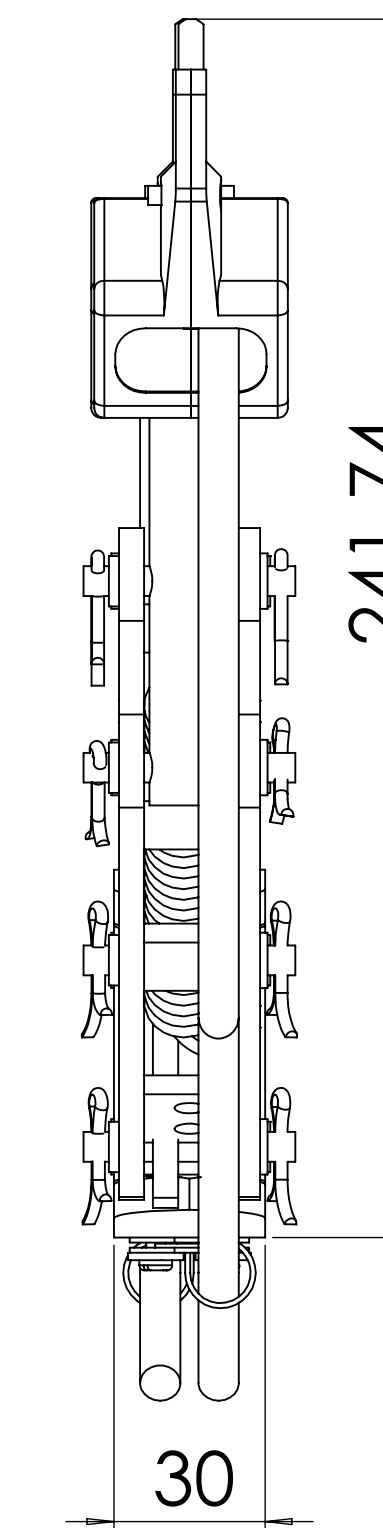
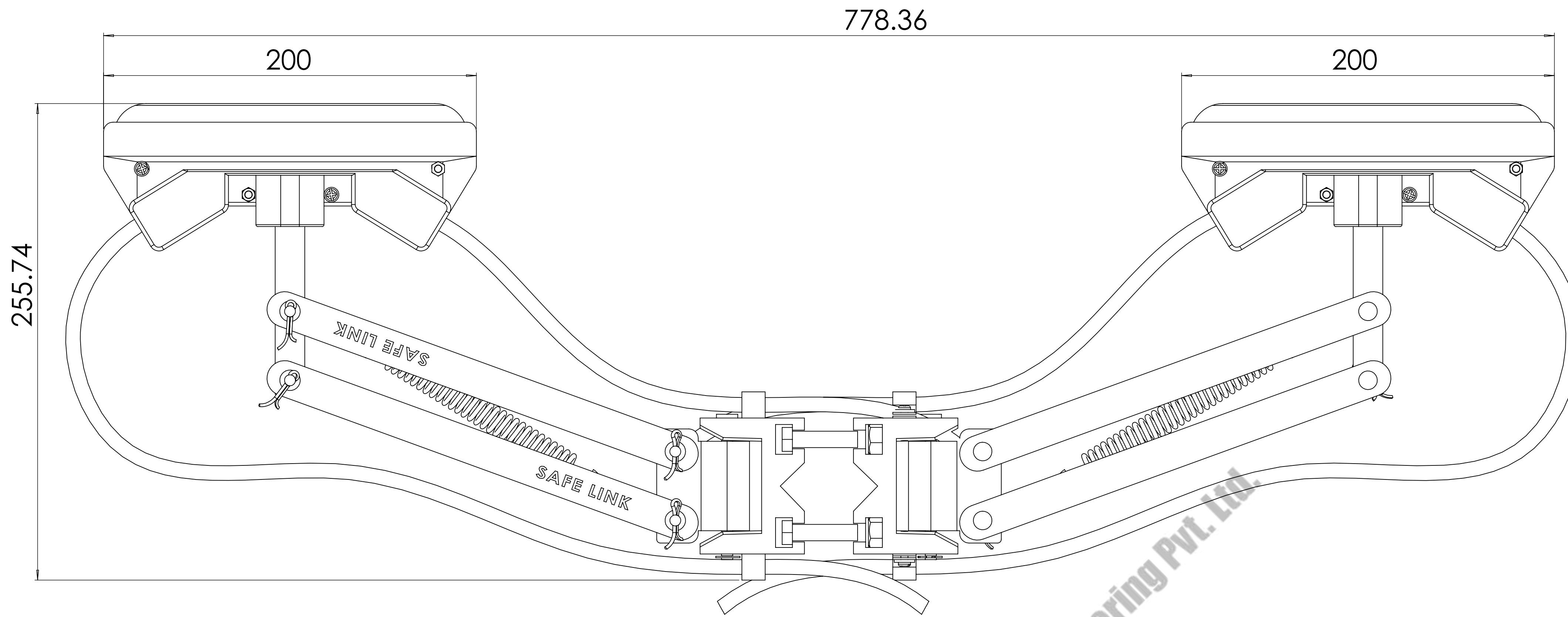

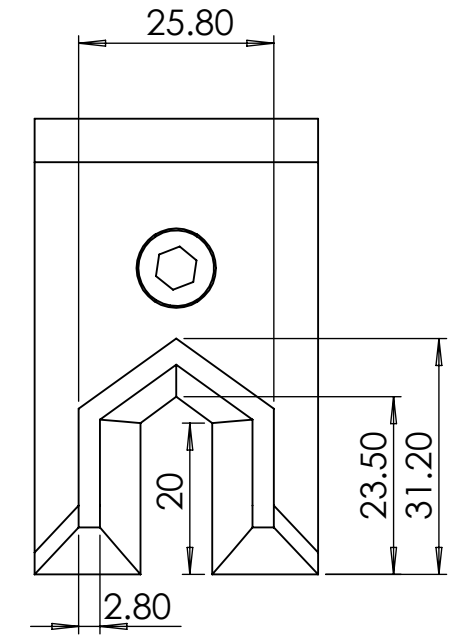
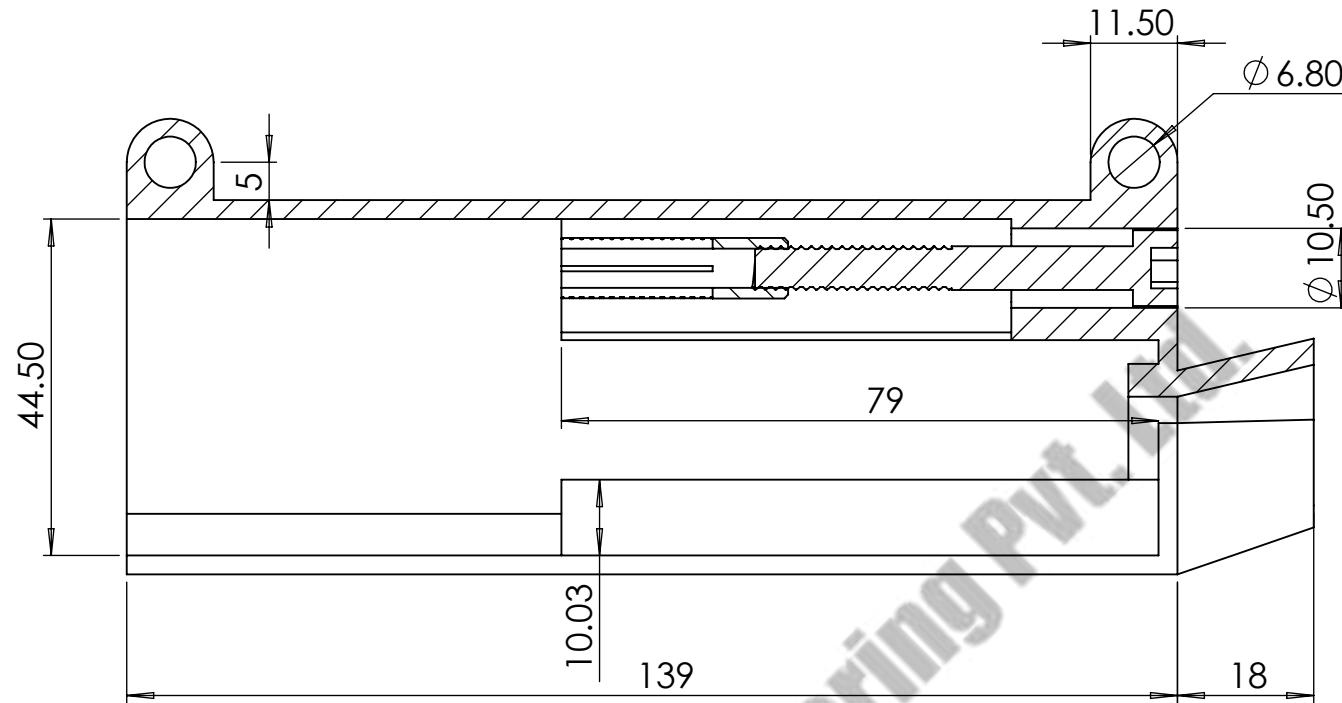
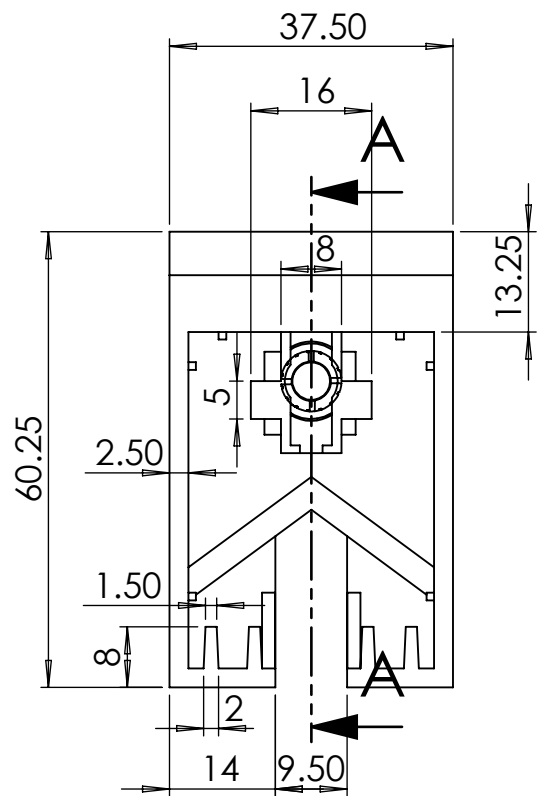

Anand Systems Engineering Pvt. Ltd.

COMPANY NAME:		ANAND SYSTEM ENGINEERING PVT LTD		DO NOT SCALE DRAWING	REVISION:
Email id: info@anandcontrol.in		FINISH:		TITLE: CURRENT COLLECTOR 500AMP 2D	
CONTACT NO: 9137620579		DATE:		DWG. NO.:	
DRWN: SAURABH		MATERIAL:		SIGNATURE:	
CHKD:				A	
APPR:				SCALE:	
MFC:		WEIGHT:		SHEET: 1 OF 1	



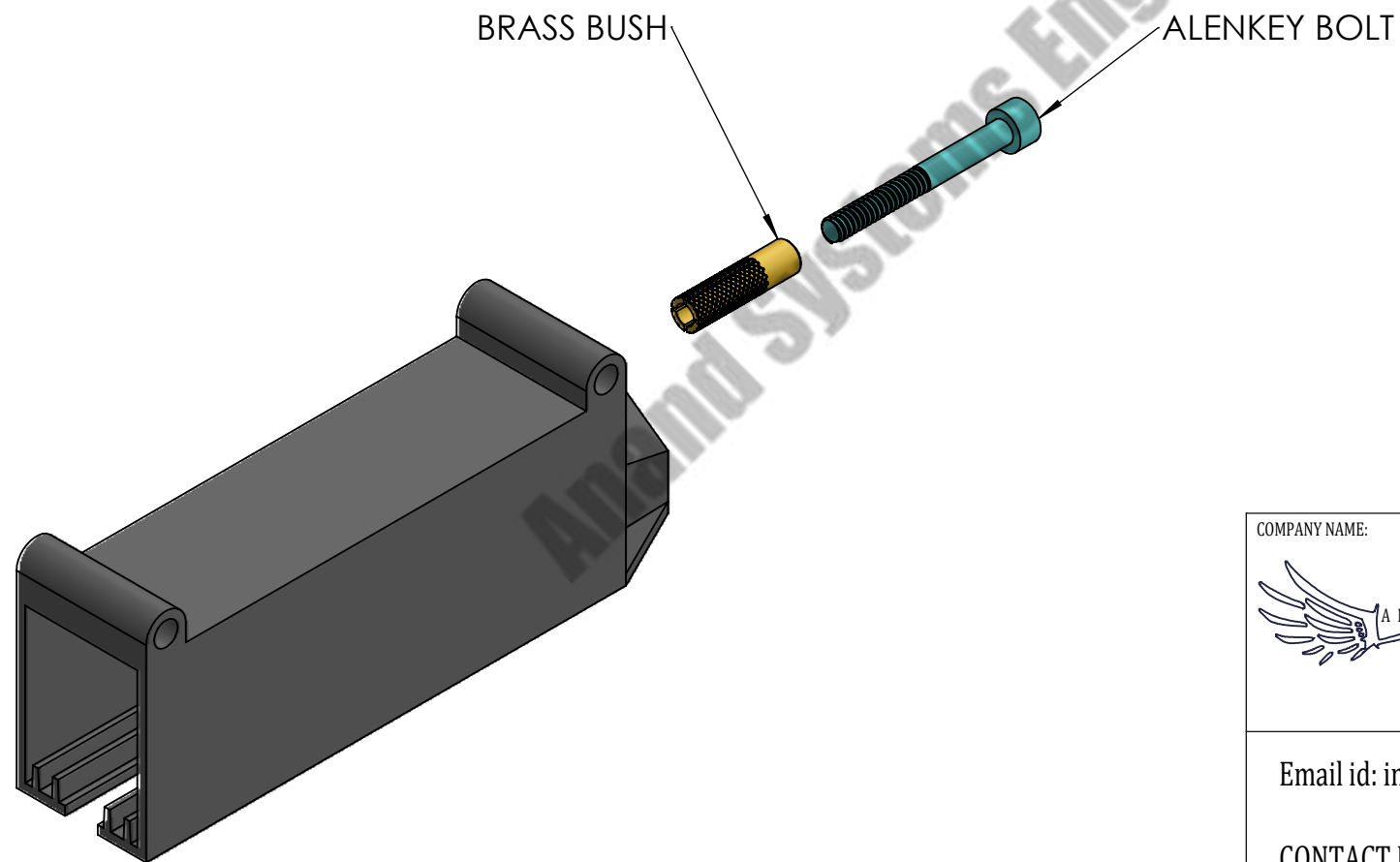

SECTION A-A  
SCALE 1 : 1



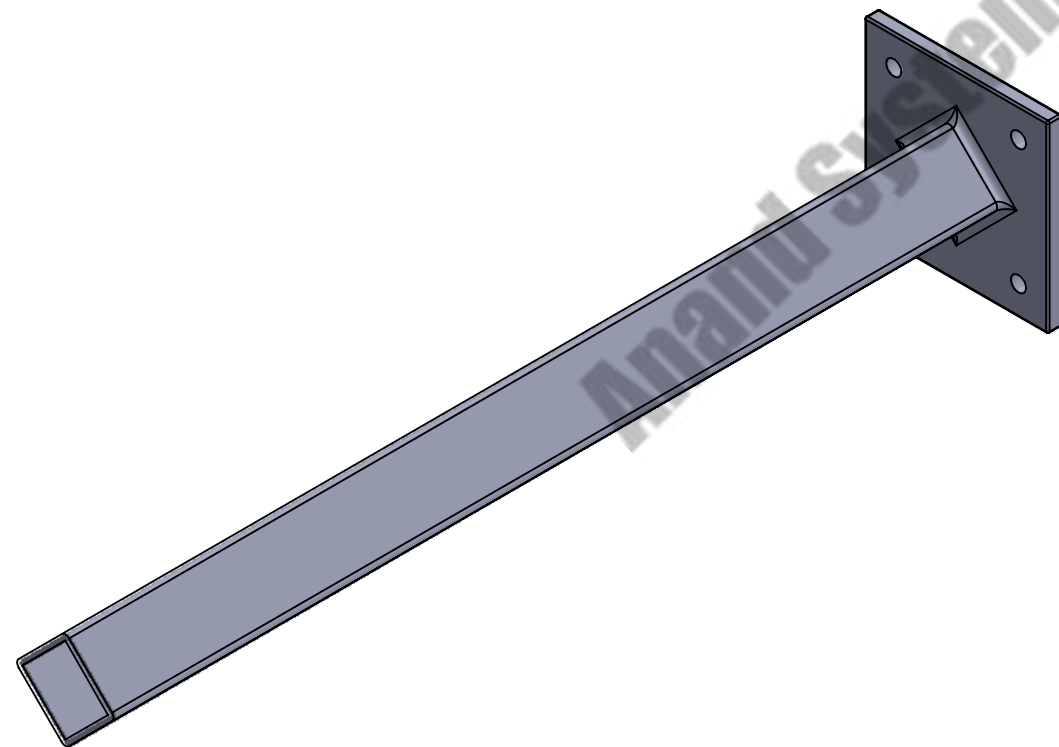
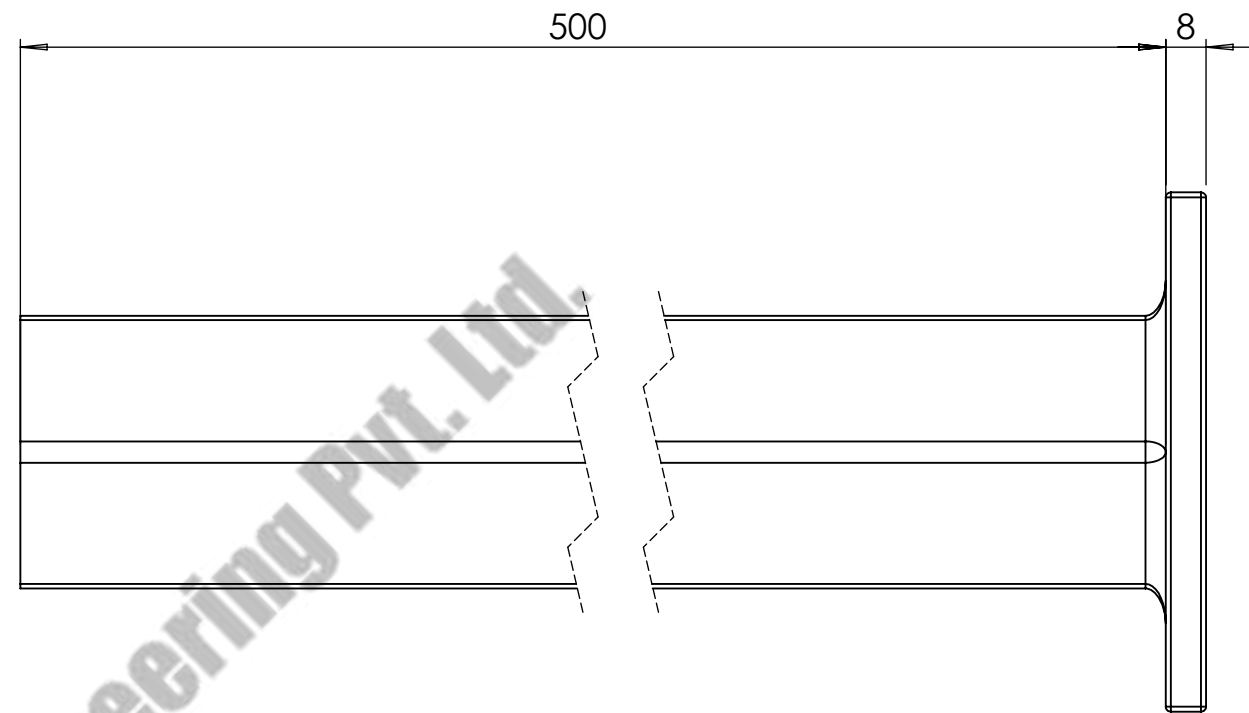
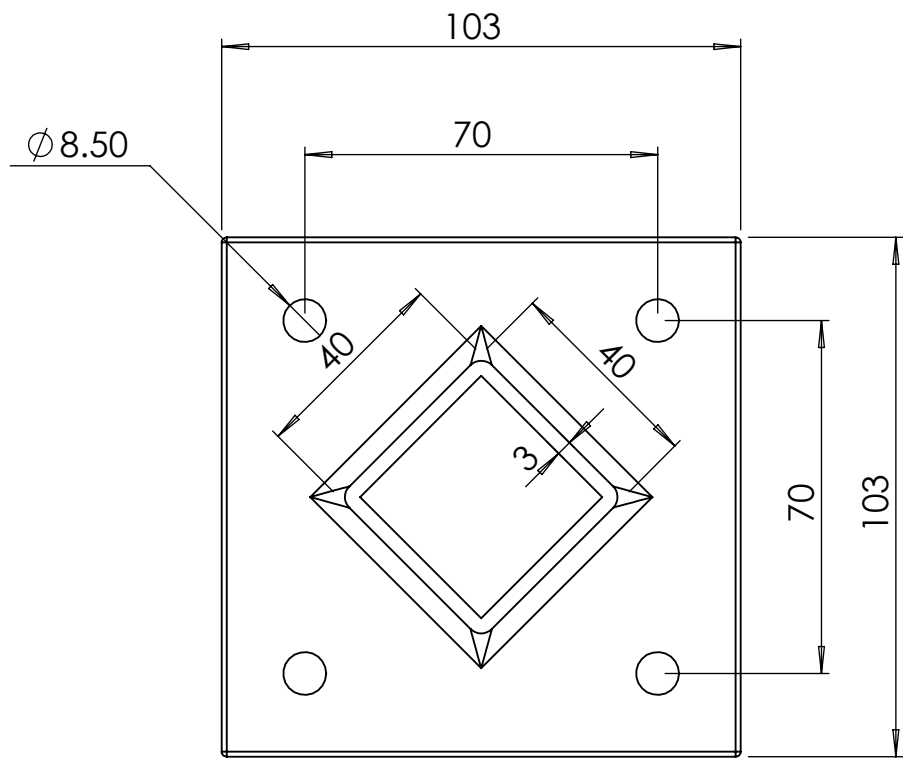

COMPANY NAME:		DO NOT SCALE DRAWING.		REVISION:	
 <b>ANAND SYSTEM ENGINEERING PVT LTD</b>		TITLE:			
		<b>END COVER V TYPE ASSM 2D</b>			
Email id: info@anandcontrol.in		FINISH:		DWG NO.	
CONTACT NO: 9137620579				DATE:	
DRAWN	SAURABH	MATERIAL:		SIGNATURE:	
CHK'D					
APP'VD					
MFG		WEIGHT:		SCALE:	
				SHEET: 1 OF 1	



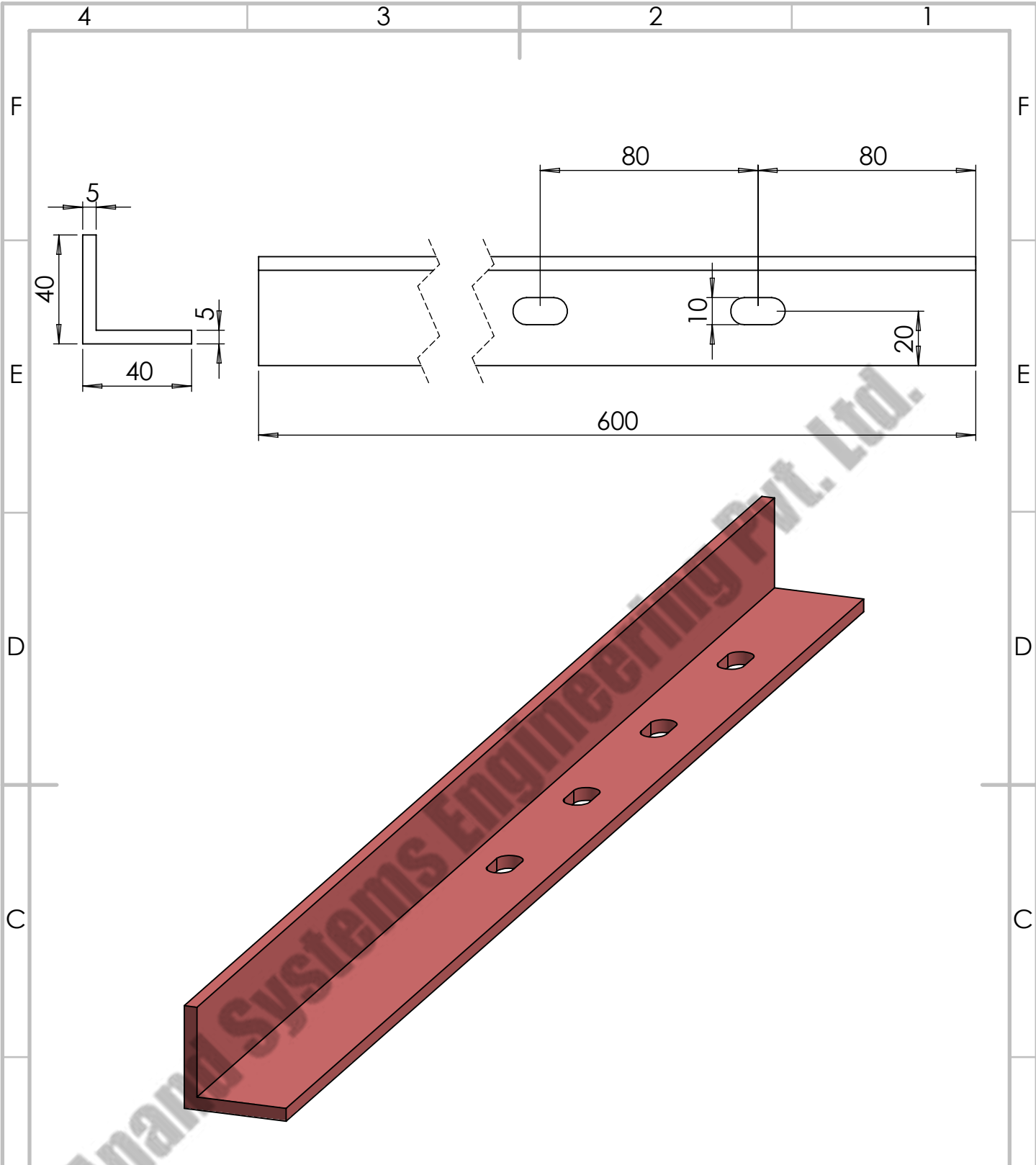

COMPANY NAME:		ANAND SYSTEM ENGINEERING PVT LTD		DO NOT SCALE DRAWING.	REVISION:
		Email id: info@anandcontrol.in CONTACT NO: 9137620579		TITLE: <b>C.C-TOWNG BRACKET V-TYPE 2D</b>	
FINISH:		MATERIAL:		DWG NO.	
DATE:		SIGNATURE:		A	
DRAWN	SAURABH			SCALE:	
CHK'D				SHEET: 1 OF 1	
APPY'D					
MFG					



COMPANY NAME:		DO NOT SCALE DRAWING.		REVISION:	
		ANAND SYSTEM ENGINEERING PVT LTD		TITLE: <b>WEB BRACKET 600 V-TYPE 2D</b>	
Email id: info@anandcontrol.in		FINISH:		DWG NO.	
CONTACT NO: 9137620579				DATE:	
DRAWN: SAURABH		MATERIAL: M.S.		SIGNATURE:	
CHK'D:				A	
APP'D:					
MFG:		WEIGHT:		SCALE:	
				SHEET: 1 OF 1	