

4

3

2

1

F

F

E

E

D

D

C

C

B

B

A

A

GALVANISED

PVC SLEEVE

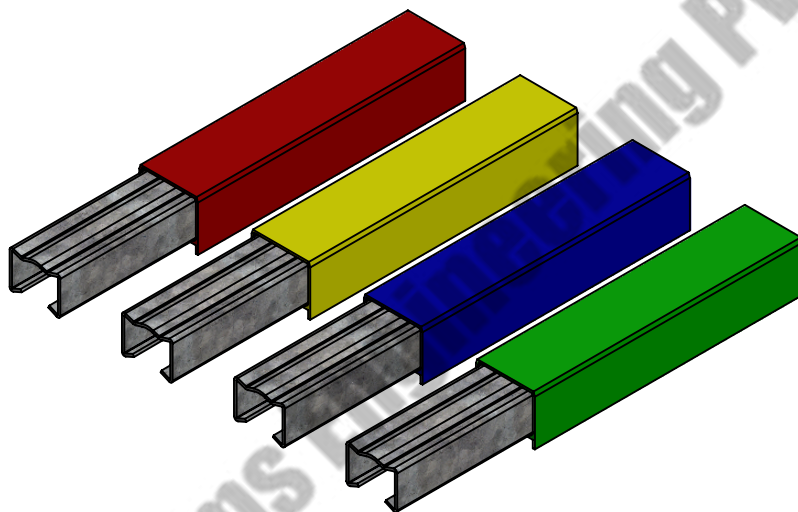
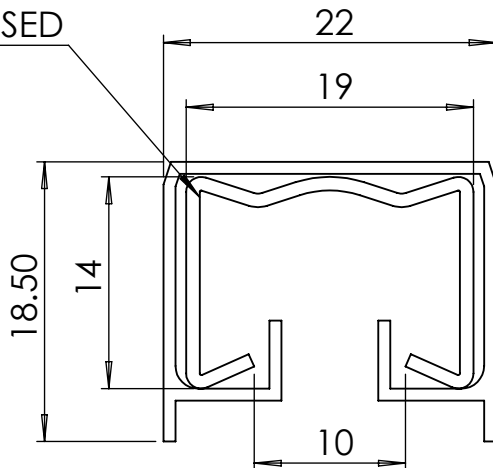

*125AMP- GI- 04 BAR PIN
TYPE (M)
RED YELLOW BLUE GREEN
COLOUR PVC*

COMPANY NAME:



**ANAND SYSTEM
ENGINEERING PVT LTD**

DO NOT SCALE DRAWING.

REVISION:

TITLE:

**SAFELINK 125Amp
RYBG GI M-TYPE
2D**

Email id: info@anandcontrol.in

CONTACT NO: 9137620579

FINISH:

DWG NO.

DATE:

SIGNATURE:

DRAWN	SAURABH
CHK'D	
APP'D	
MFG	

MATERIAL:

WEIGHT:

SCALE:

SHEET: 1 OF 1

A

4

3

2

1

ITEM NO.	PART NAME	DESCRIPTION	MATERIAL	QTY.
1	4 POLE HANGER CLAMP ASSM M-TYPE	151X57X20	DELRIN	1
	4 POLE HANGER CLAMP M-TYPE	151X37X20	DELRIN	1
	HEX BOLT	M8, 8X25	M.S.	2
	M8 PLAIN WASHER	17X8.4X1.5	M.S.	2
	HEX NUT	M8	M.S.	2
	SPRING WASHER	M8	SPRING STEEL 4454 GRADE-02	2
2	DSL BUSBAR ASSM M TYPE	4 MTR	GALVANISED	4
	DSL BUSBAR GI M-TYPE	4MTR	PVC	1
	DSL BUSBAR SLEEVE M-TYPE	4MTR	PVC	1
3	JOINT COVER M-TYPE	40X26X25	DELRIN	8
4	Web-Bracket M-TYPE	40X40X400, THK-5 MM	M.S.	3
5	3 POLE HANGER CLAMP ASSM M-TYPE	109X57X20	DELRIN	1
	3 POLE HANGER CLAMP M-TYPE	109X37X20	DELRIN	1
	HEX BOLT	M8, 8X25	M.S.	1
	M8 PLAIN WASHER	17X8.4X1.5	M.S.	1
	HEX NUT	M8	M.S.	1
	SPRING WASHER	M8	SPRING STEEL 4454 GRADE-02	1
6	ANCHOR CLAMP ASSM M-TYPE	25X34X37	DELRIN	1
	ANCHOR CLAMP M-TYPE	25X34X17	DELRIN	1
	ANCHOR CLAMP PART 1	25X20X10	DELRIN	2
	BOLT 3X40	M3 X40	M.S.	1
	HEX NUT	M3	M.S.	1
	HEX BOLT	M8, 8X25	M.S.	1
	M8 PLAIN WASHER	17X8.4X1.5	M.S.	1
	HEX NUT	M8	M.S.	1
	SPRING WASHER	M8	SPRING STEEL 4454 GRADE-02	1
7	CENTRE POWER FEED M-TYPE	124X63X24	PPCP	4
	MOULDING CENTRE POWER FEED COVER	124X63X24	PPCP	2
	GI-CLAMP	60X18.5	GALVANISED	2
	SS CLAMP	52X27, 1 THK	S.S	2
	GRUMET	GRUMET 3/4"	RUBBER	2
	HEX BOLT	M8, 8X15	M.S.	1
	HEX NUT	M8	M.S.	1
	SPRING WASHER	M8	SPRING STEEL 4454 GRADE-02	1
	HEX NUT	M4	M.S.	3
	PAN HEADED SCREW	4X10	M.S.	1
	PAN HEADED SCREW	4X15	M.S.	2
8	SINGLE POLE HANGER CLAMP ASSM M-TYPE	25X55X17	DELRIN	4
	SINGLE POLE HANGER CLAMP	25X34X17	DELRIN	1
	HEX BOLT	M8, 8X25	M.S.	1
	M8 PLAIN WASHER	17X8.4X1.5	M.S.	1
	HEX NUT	M8	M.S.	1
	SPRING WASHER	M8	SPRING STEEL 4454 GRADE-02	1
9	END POWER FEED ASSM M-TYPE.SLDPRT			8
	BOLT	M6X15	M.S.	1
	HEX NUT	M6	M.S.	1
	PLAIN WASHER M6	13X6.5X1.5	M.S.	1
	SPRING WASHER	M6	SPRING STEEL 4454 GRADE-02	1
11	CURRENT COLLECTOR ASSM	60,100,125,250 AMP		4
	ARM 1	220X16X3	M.S.	4
	LOWER BRACKET	56X73X30	CASTING	1
	LOWER PIN	16X70	M.S.	1
	VERTICAL LEVER CC	50X61X24	PLASTIC	1
	SPACER PIN	26X Ø 6	M.S.	6
	UPPER BRACKET	108.5X43X10	PLASTIC	2
	VERTICAL STUD	104X Ø 7	M.S.	1
	SHOE HOLDER	108.5X20X40	PLASTIC	1
	CONTACT PATTI	87X47X3	COPPER	1
	SPRING	Ø 13.5X22	SPRING STEEL 4454 GRADE-02	1
	LOWER BRACKET CC 2	70X30X3	M.S.	1
	HEX BOLT	8X40	M.S.	2
	PLAIN WASHER W TYPE	18.5X9X1.5	M.S.	2
	HEX NUT	M4	M.S.	2
	TENSION SPRING	Ø 15X115	SPRING STEEL 4454 GRADE-02	1
	wire	105 SQ MM, 1mtr		1
	PAN HEADED SCREW	4X15	M.S.	2
	NUT	M6	M.S.	2
11	C.C-Bracket	80X60XTHK-5, SQ-25X25X400	M.S.	1
12	END COVER M-TYPE	L-73, SQ30X30	PVC	4
13	END POWER FEED COVER M-TYPE	L-102, SQ30X30	PVC	4
14	JOINT CLAMP PIN	60X12X3	GALVANISED	8

EXPLODED VIEW

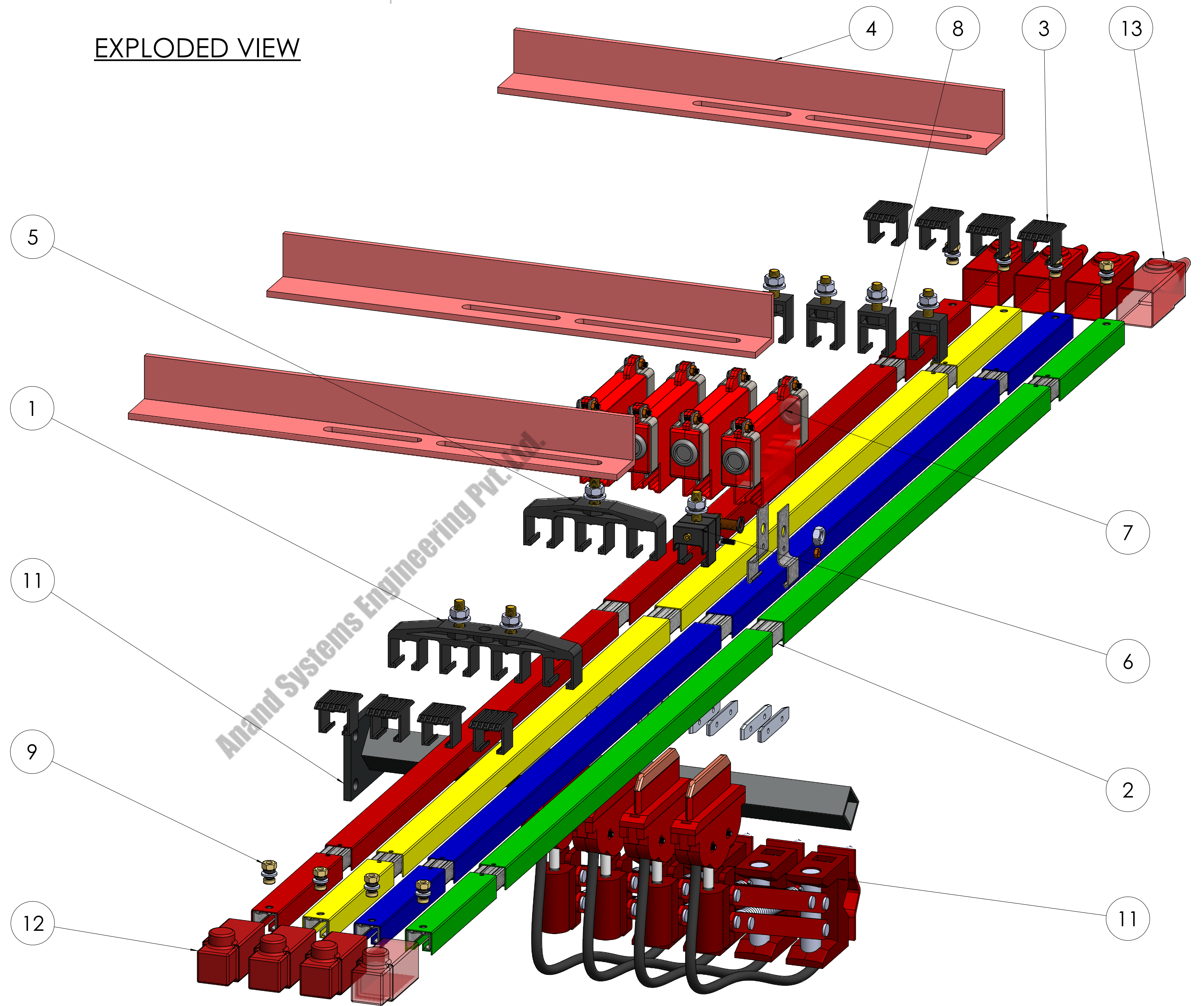

COMPANY NAME:		ANAND SYSTEM ENGINEERING PVT LTD	
Email id: info@anandcontrol.in		CONTACT NO: 9137620579	
DRAWN: SAURABH		MATERIAL:	
CHKD:		WEIGHT:	
APPRD:		SCALE: 1 OF 1	
MFC:		SIGNATURE:	
DATE: 02-01-2025		SHEET: 1 OF 1	

16 15 14 13 12 11 10 9 8 7 6 5 4 3 2 1

M L K J H G F E D C B A

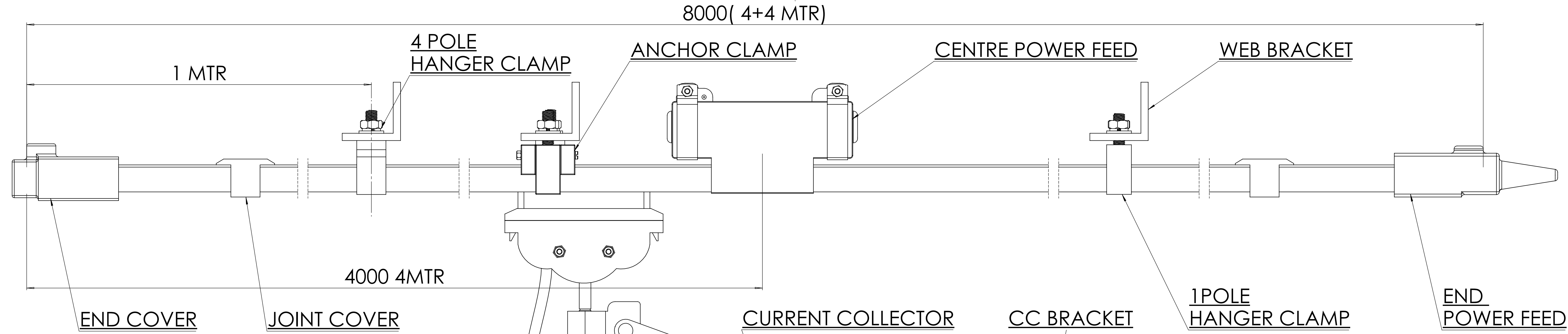

43 (DISTANCE BETWEEN 2 DSL BUSBAR)

43 43

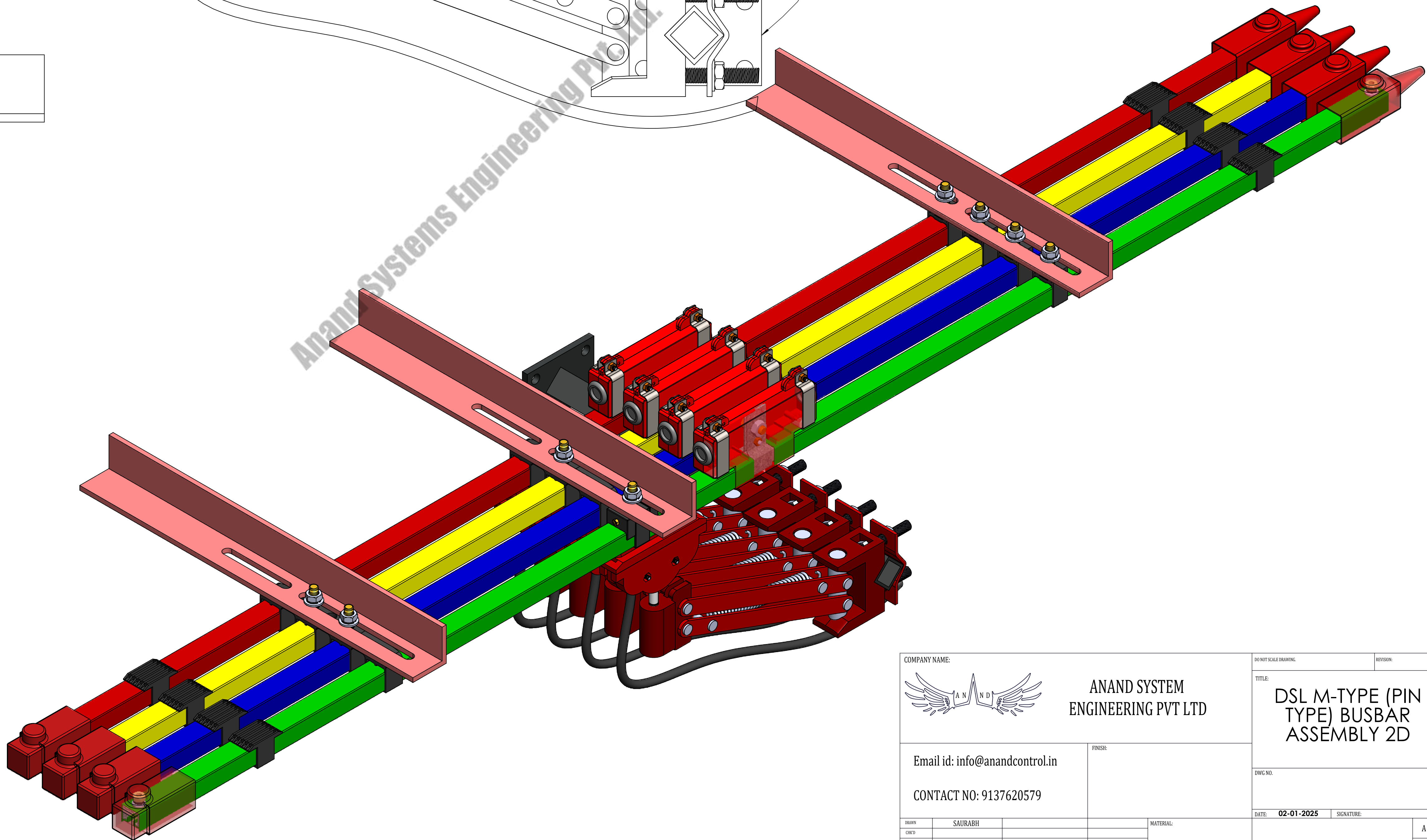
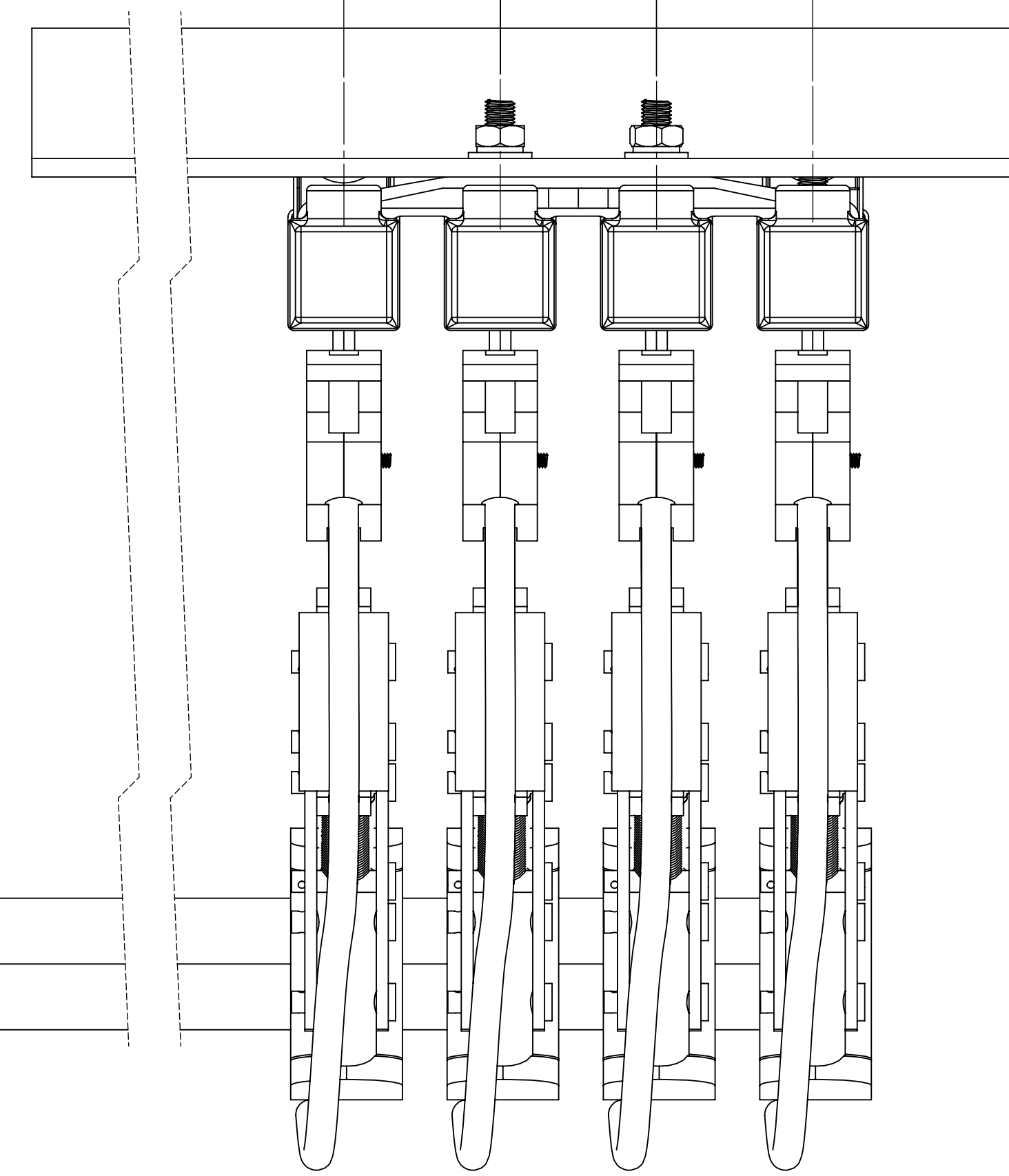

COMPANY NAME:		ANAND SYSTEM ENGINEERING PVT LTD		DO NOT SCALE DRAWING	REVISION:
Email id: info@anandcontrol.in		FINISH:		TITLE: DSL M-TYPE (PIN TYPE) BUSBAR ASSEMBLY 2D	
CONTACT NO: 9137620579		DATE: 02-01-2025		SIGNATURE:	
DRWN: SAURABH	CKTD:	APPRD:	MFC:	MATERIAL:	WEIGHT:
				SCALE:	SHEET: 1 OF 1

16 15 14 13 12 11 10 9 8 7 6 5 4 3 2 1

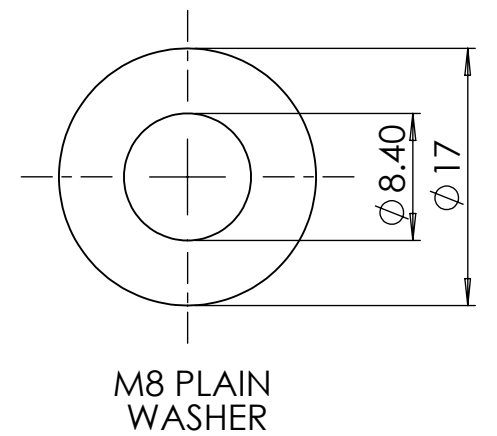
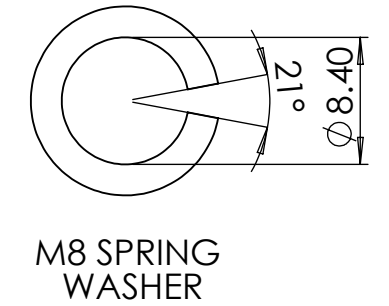
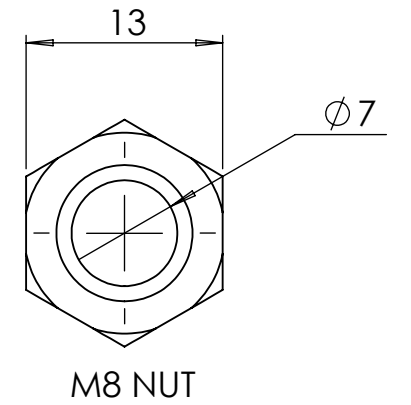
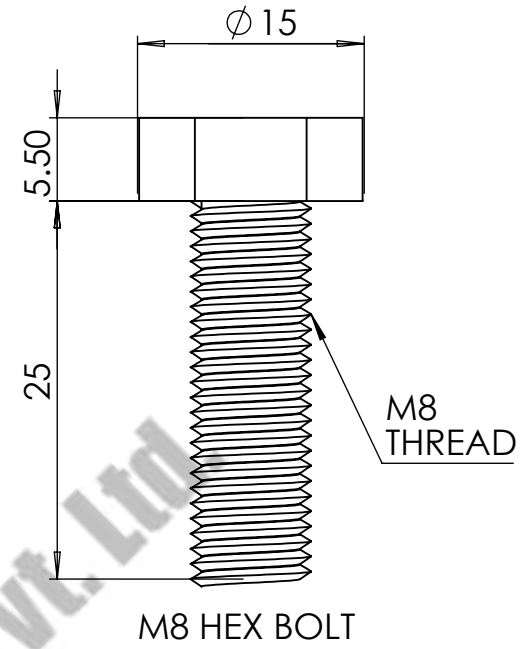
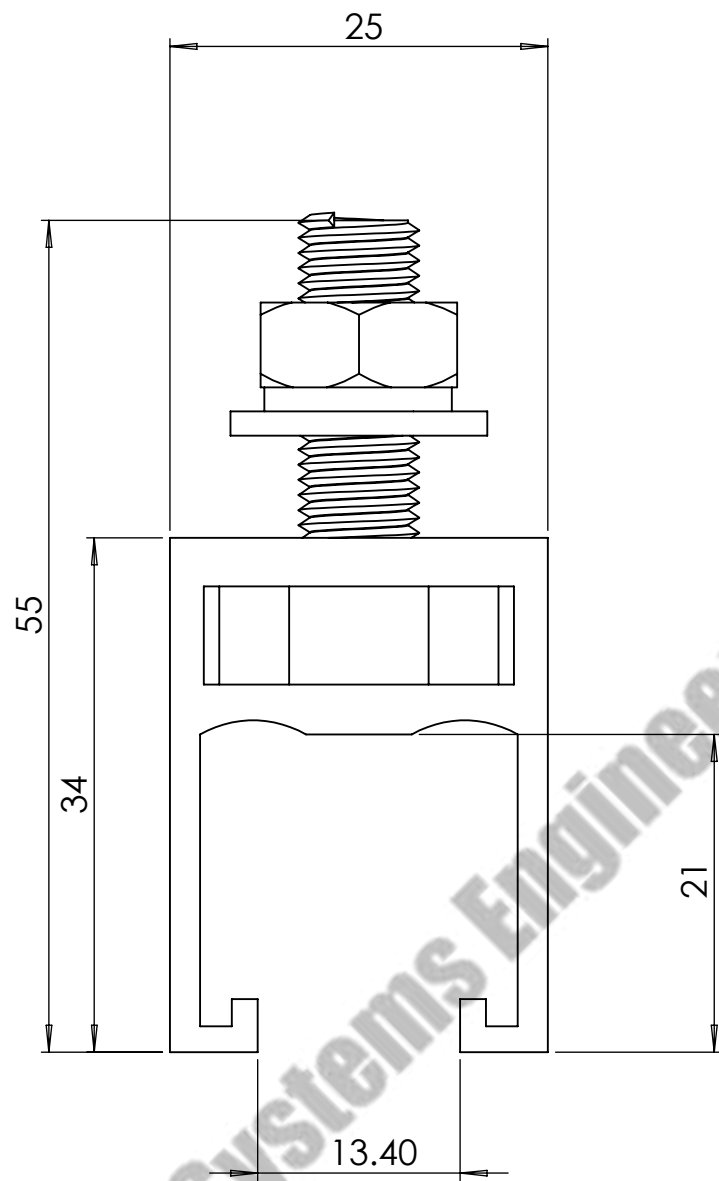
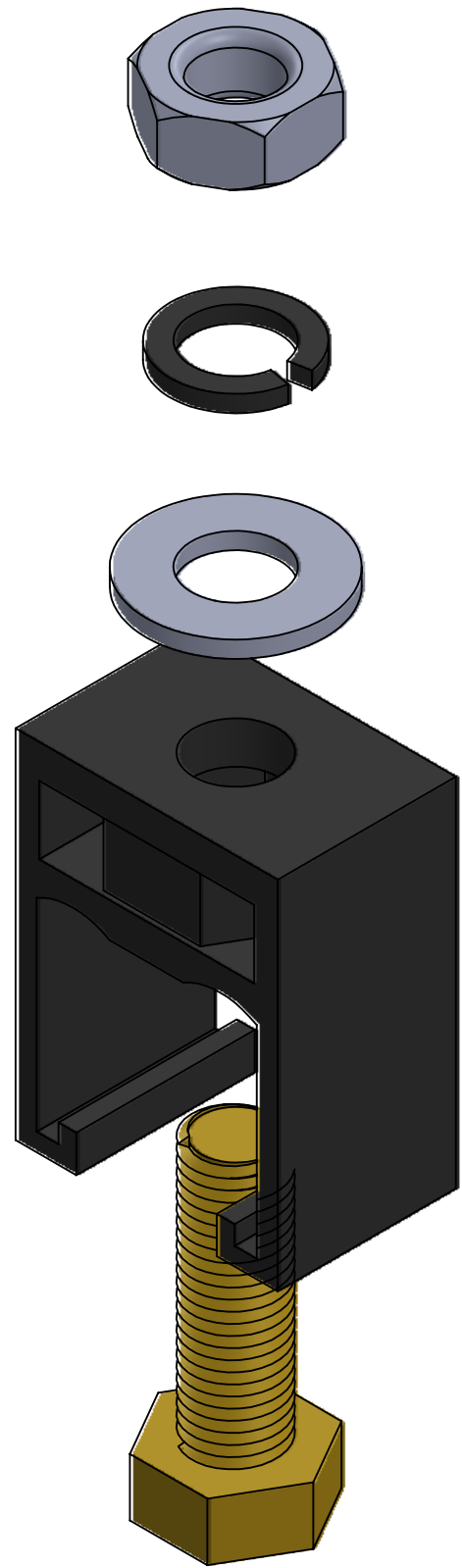

Anand Systems Engineering Pvt. Ltd.

COMPANY NAME:		ANAND SYSTEM ENGINEERING PVT LTD		DO NOT SCALE DRAWING.	REVISION:
		Email id: info@anandcontrol.in CONTACT NO: 9137620579		TITLE: SINGLE POLE HANGER CLAMP ASSM M-TYPE 2D	
MATERIAL:		FINISH:		DWG NO.	
DATE:		SIGNATURE:		A	
DRAWN: SAURABH	CHK'D:	APPY'D:	MFG:	SCALE:	SHEET: 1 OF 1

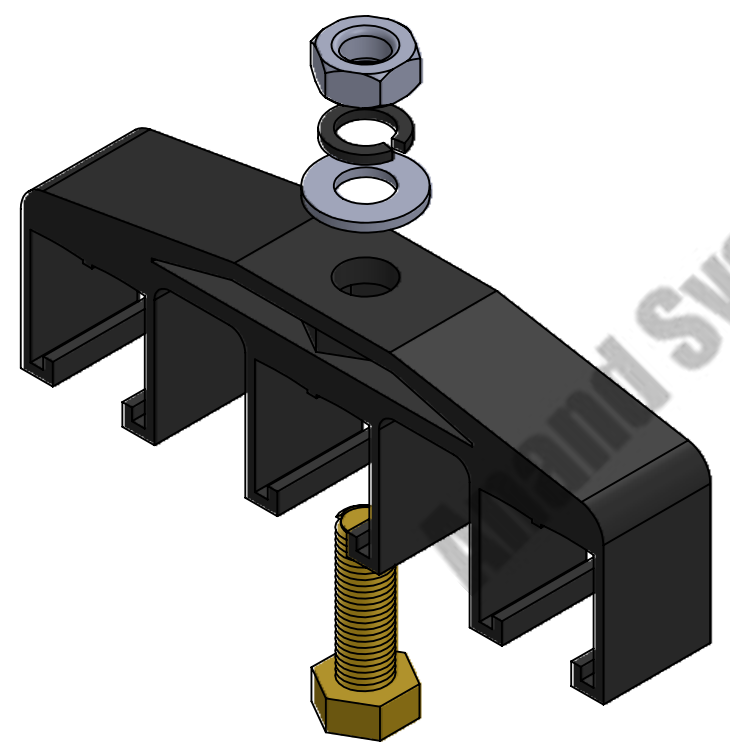
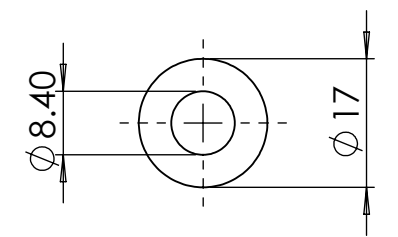
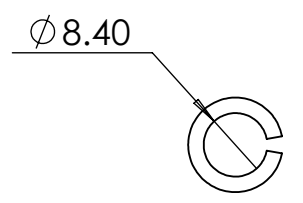
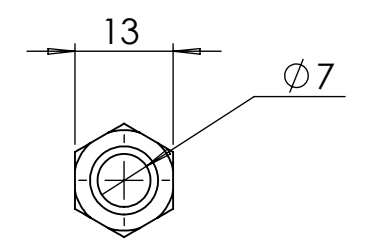
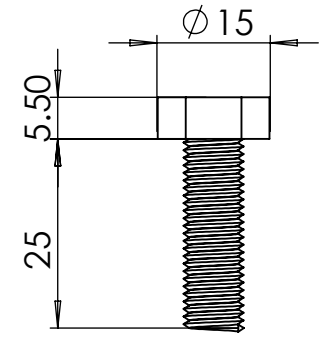
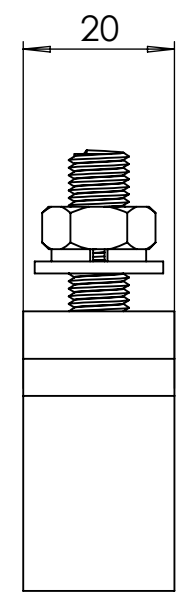
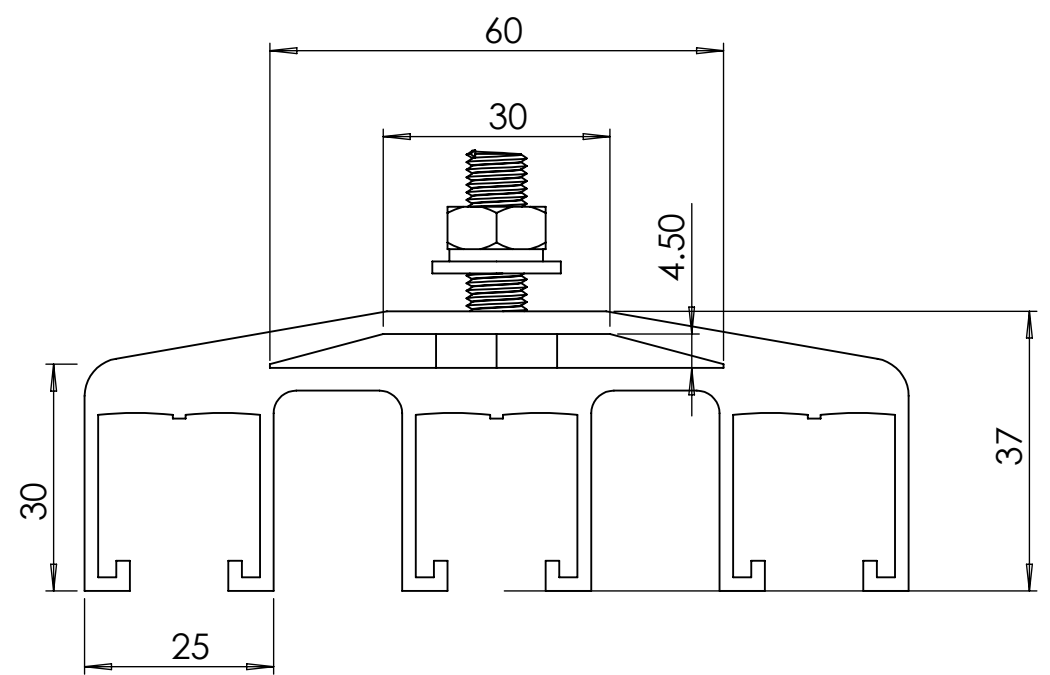

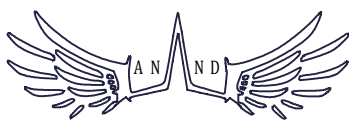

Anand Systems Engineering Pvt. Ltd.

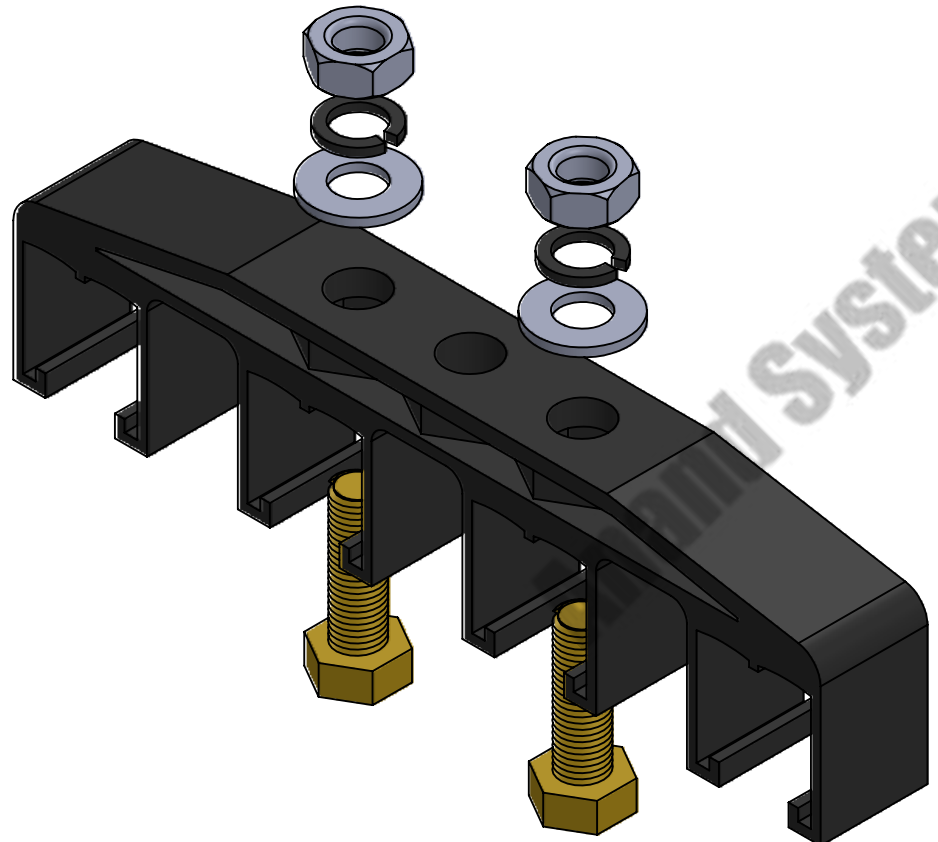
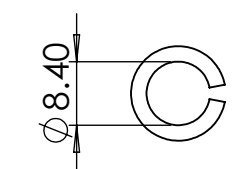
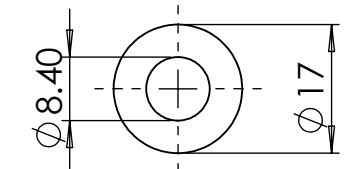
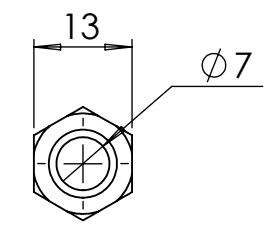
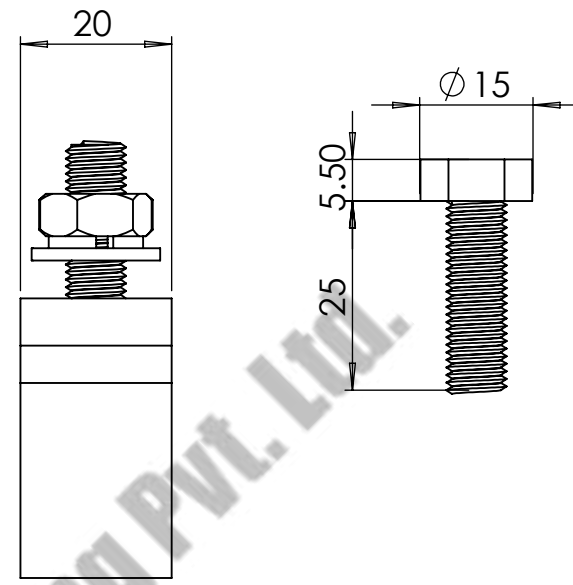
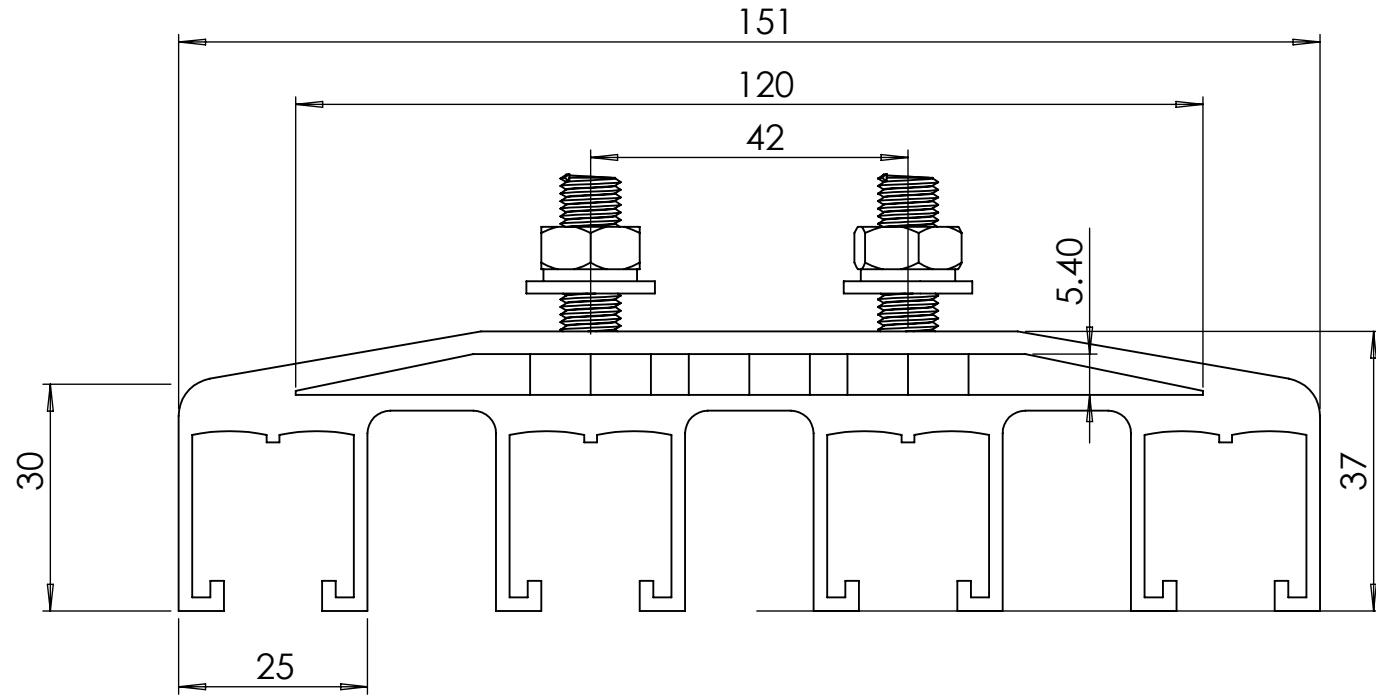
COMPANY NAME:		ANAND SYSTEM ENGINEERING PVT LTD		DO NOT SCALE DRAWING.	REVISION:
		Email id: info@anandcontrol.in CONTACT NO: 9137620579		TITLE: 3 POLE HANGER CLAMP ASSM M-TYPE 2D	
FINISH:		MATERIAL:		DWG NO.	
DATE:		SIGNATURE:		A	
DRAWN	SAURABH			SCALE:	
CHK'D				SHEET: 1 OF 1	
APPY'D					
MFG					

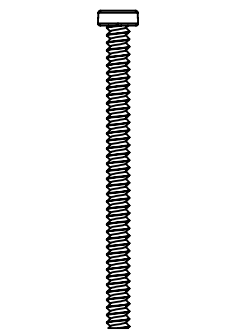
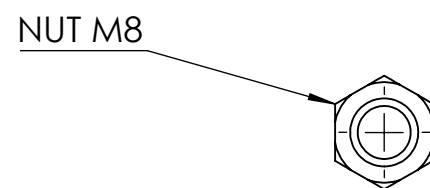
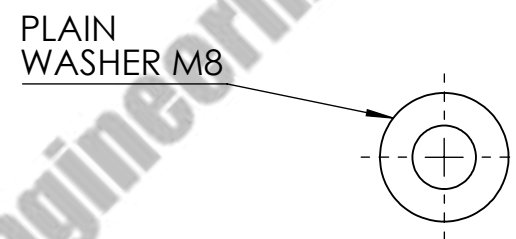
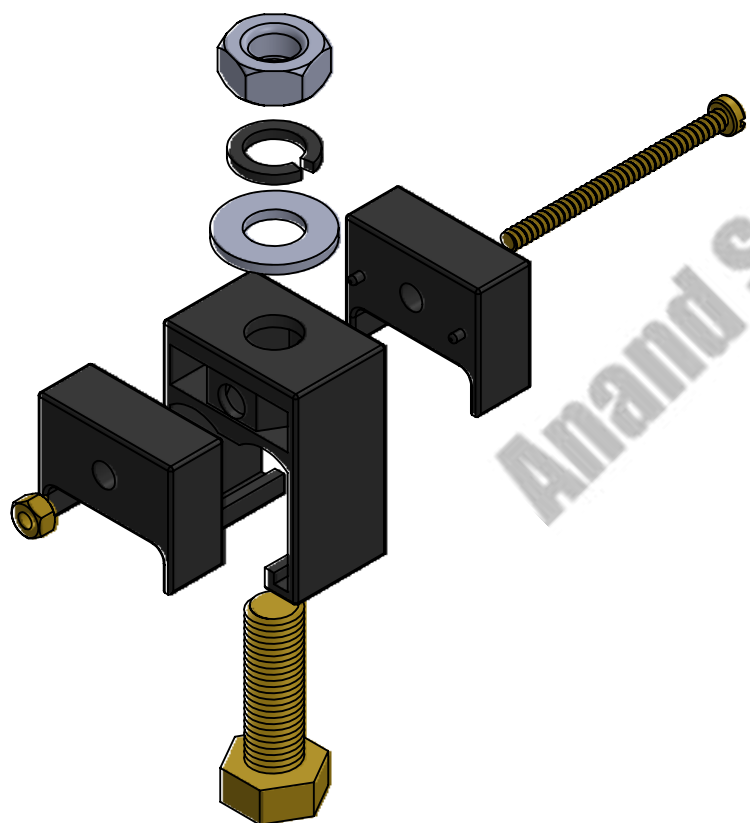
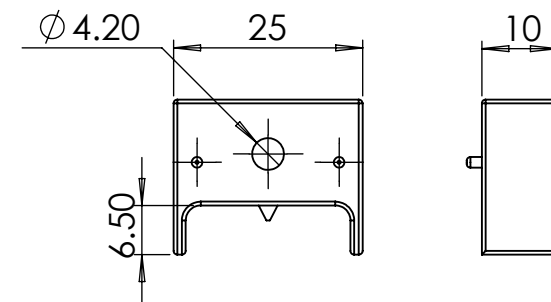
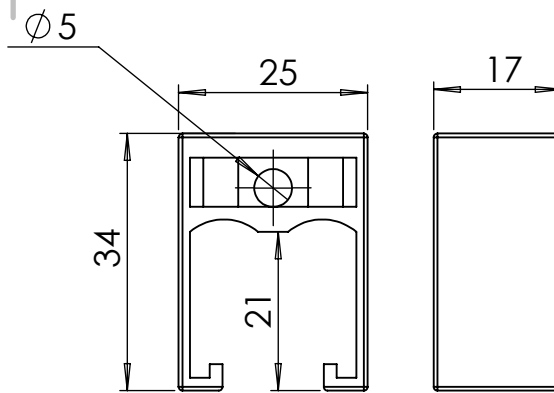
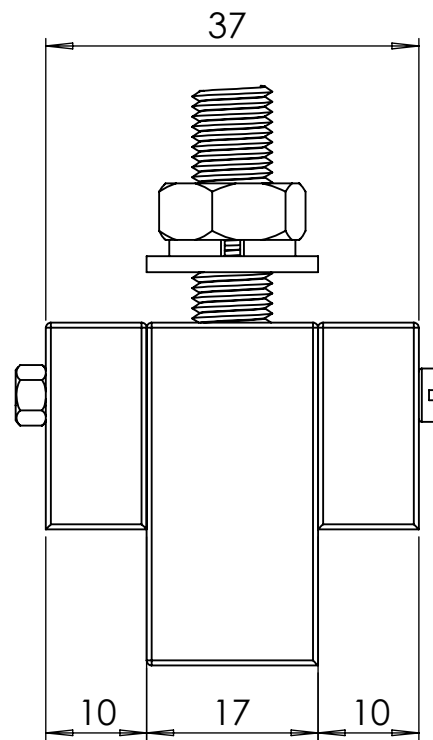
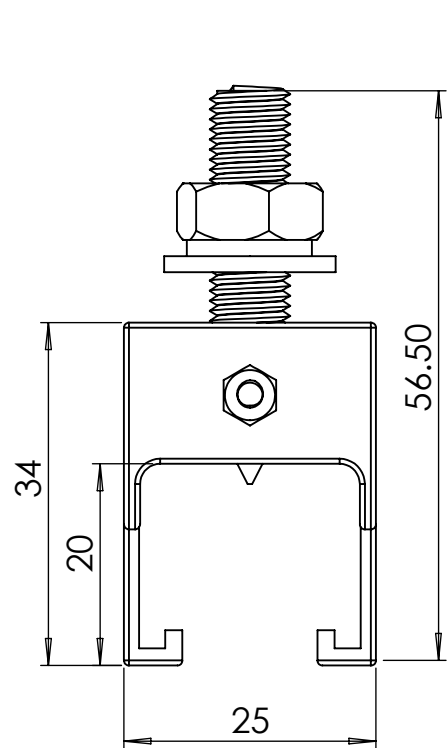

COMPANY NAME:		ANAND SYSTEM ENGINEERING PVT LTD		DO NOT SCALE DRAWING.	REVISION:
		Email id: info@anandcontrol.in CONTACT NO: 9137620579		TITLE: 4 POLE HANGER CLAMP ASSM M-TYPE 2D	
FINISH:		MATERIAL:		DWG NO.	
DATE:		SIGNATURE:		A	
DRAWN: SAURABH				SCALE:	SHEET: 1 OF 1
CHK'D:					
APP'D:					
MFG:					



COMPANY NAME:		ANAND SYSTEM ENGINEERING PVT LTD		DO NOT SCALE DRAWING.	REVISION:
		<p>Email id: info@anandcontrol.in</p> <p>CONTACT NO: 9137620579</p>		<p>TITLE:</p> <p>ANCHOR CLAMP ASSM M-TYPE 2D</p>	
FINISH:		MATERIAL: DELRIN		DWG NO.	
DATE:	SIGNATURE:		A		
DRAWN: SAURABH	MATERIAL: DELRIN		SCALE:		
CHK'D:	WEIGHT:		SHEET: 1 OF 1		
APP'D:					
MFG:					

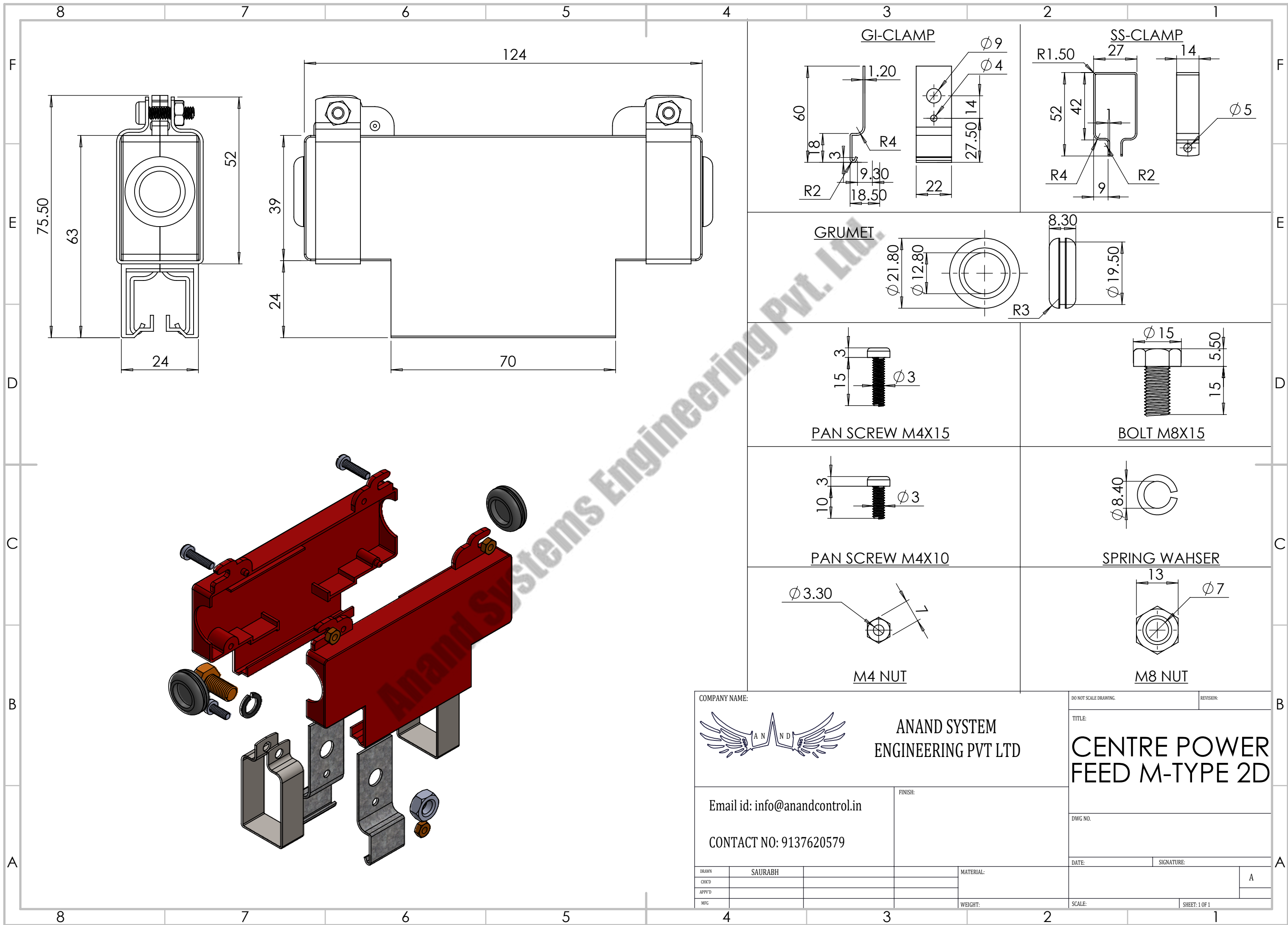

COMPANY NAME:		ANAND SYSTEM ENGINEERING PVT LTD		DO NOT SCALE DRAWING.	REVISION:
		ANAND SYSTEM ENGINEERING PVT LTD		TITLE:	
Email id: info@anandcontrol.in		FINISH:		CENTRE POWER FEED M-TYPE 2D	
CONTACT NO: 9137620579		MATERIAL:		DWG NO.	
DRAWN	SAURABH			DATE:	SIGNATURE:
CHK'D					
APP'VD					
MFG				SCALE:	SHEET: 1 OF 1
		WEIGHT:		A	

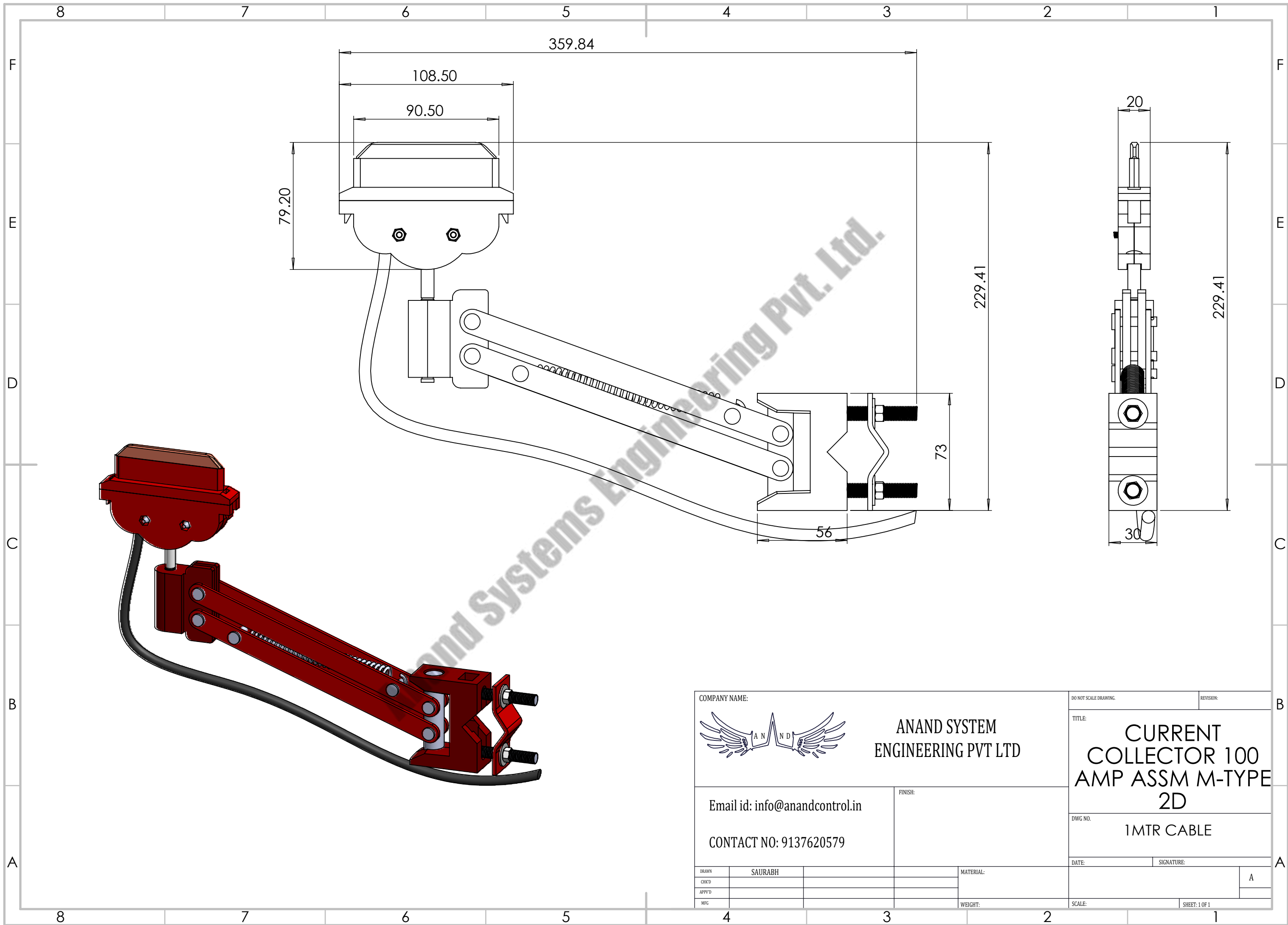

COMPANY NAME:		ANAND SYSTEM ENGINEERING PVT LTD		DO NOT SCALE DRAWING.	REVISION:
		<p>Email id: info@anandcontrol.in</p> <p>CONTACT NO: 9137620579</p>		<p>TITLE:</p> <p>CURRENT COLLECTOR 100 AMP ASSM M-TYPE 2D</p>	
FINISH:		MATERIAL:		<p>DWG NO.</p> <p>1MTR CABLE</p>	
DATE:	SIGNATURE:		A		
SCALE:	SHEET: 1 OF 1				

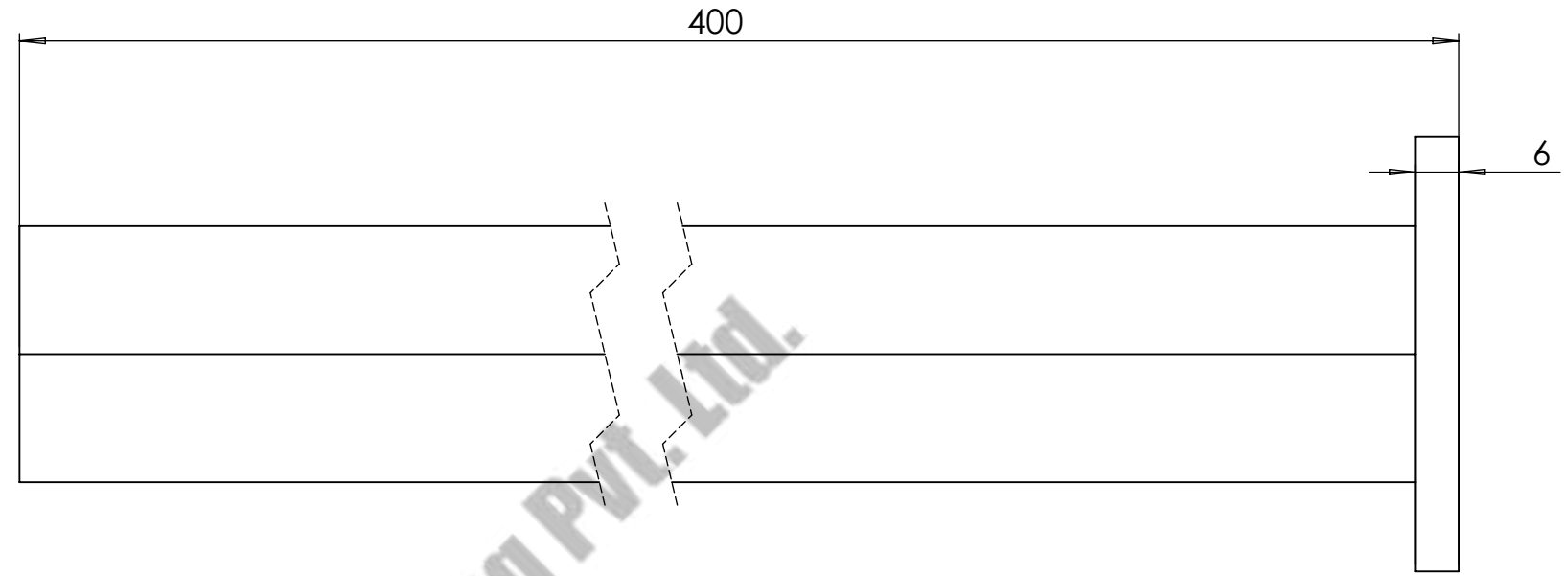
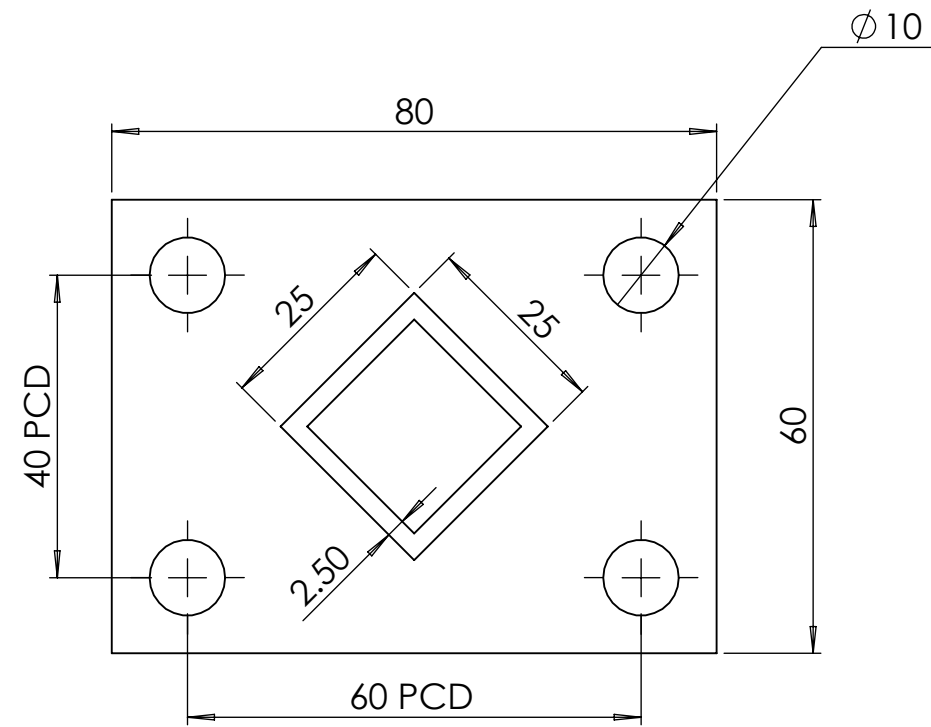

COMPANY NAME:		ANAND SYSTEM ENGINEERING PVT LTD		DO NOT SCALE DRAWING.	REVISION:
		<p>ANAND SYSTEM ENGINEERING PVT LTD</p>		TITLE: C.C-Bracket M-TYPE	
Email id: info@anandcontrol.in		FINISH:		DWG NO.	
CONTACT NO: 9137620579				DATE:	
DRAWN	SAURABH			SIGNATURE:	
CHK'D				A	
APPY'D					
MFG				SCALE:	SHEET: 1 OF 1

4

3

2

1

F

F

E

E

D

D

C

C

B

B

A

A

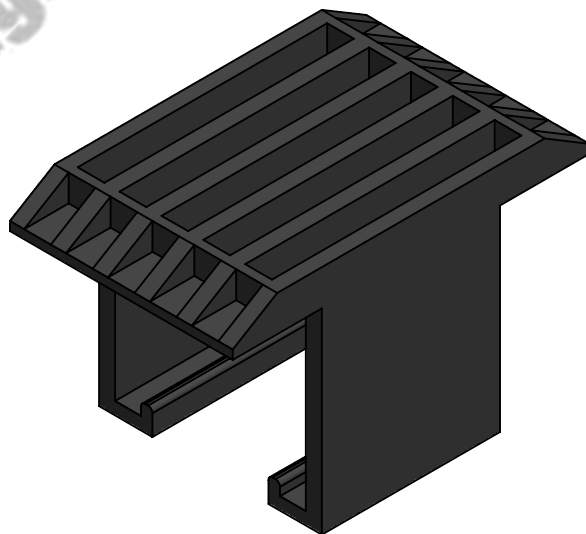
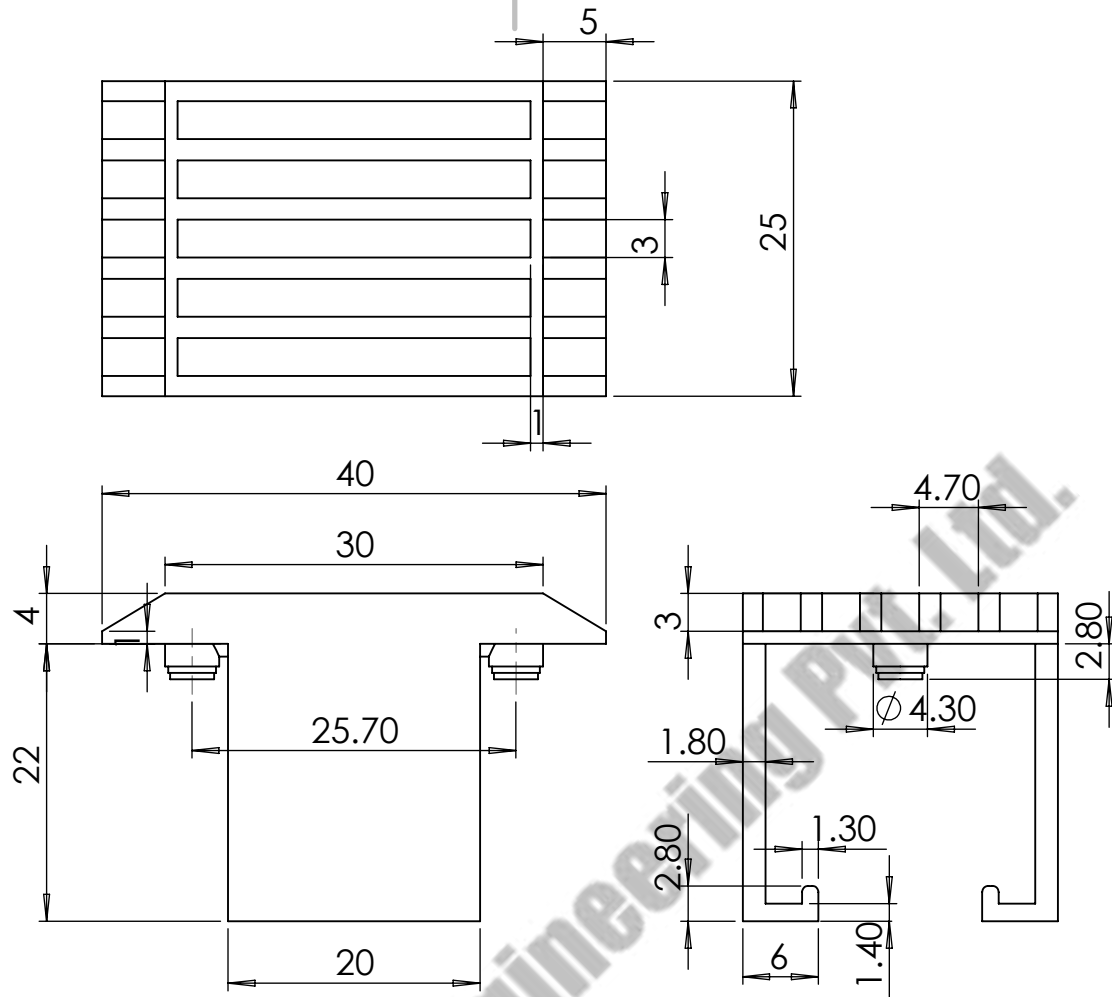

COMPANY NAME:



ANAND SYSTEM
ENGINEERING PVT LTD

DO NOT SCALE DRAWING.

REVISION:

TITLE:

JOINT COVER
M TYPE 2D

Email id: info@anandcontrol.in

CONTACT NO: 9137620579

FINISH:

DWG NO.

DATE:

SIGNATURE:

A

DRAWN	SAURABH
CHK'D	
APP'D	
MFG	

SAURABH

MATERIAL:

WEIGHT:

SCALE:

SHEET: 1 OF 1

4

3

2

1

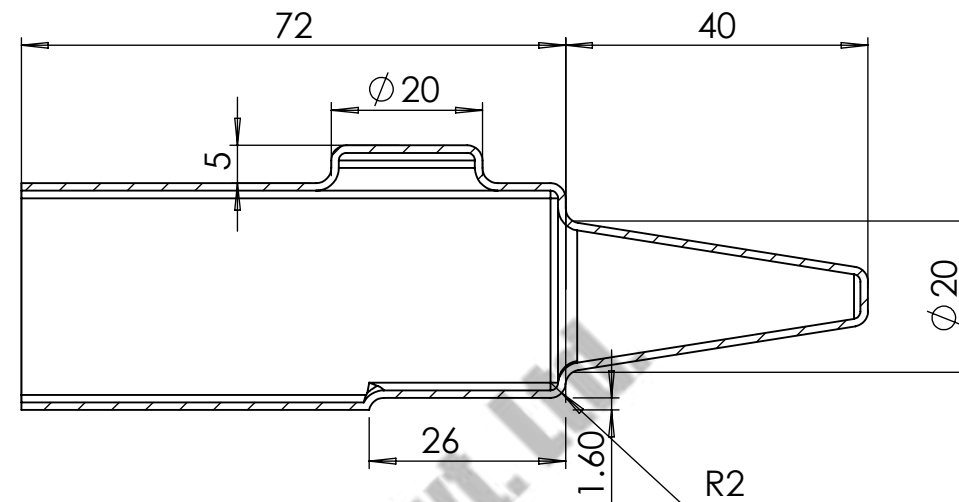
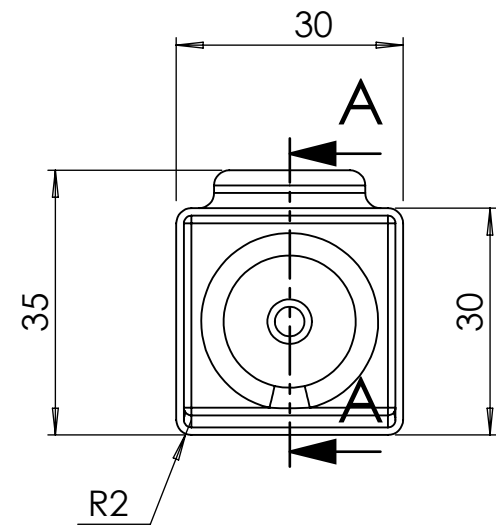

SECTION A-A

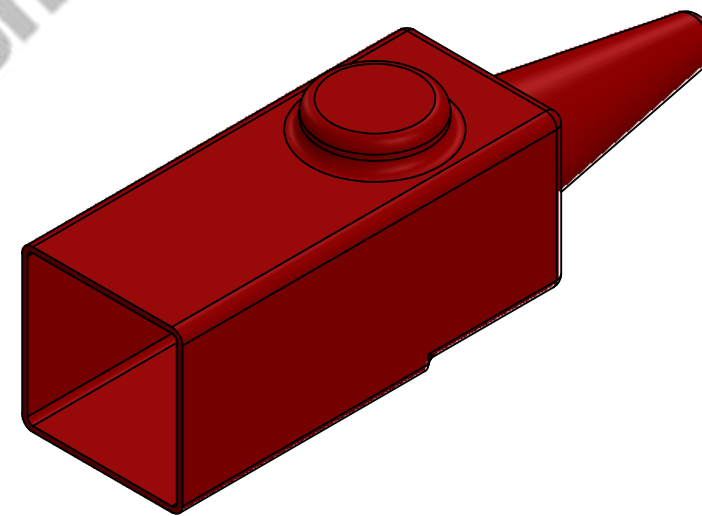
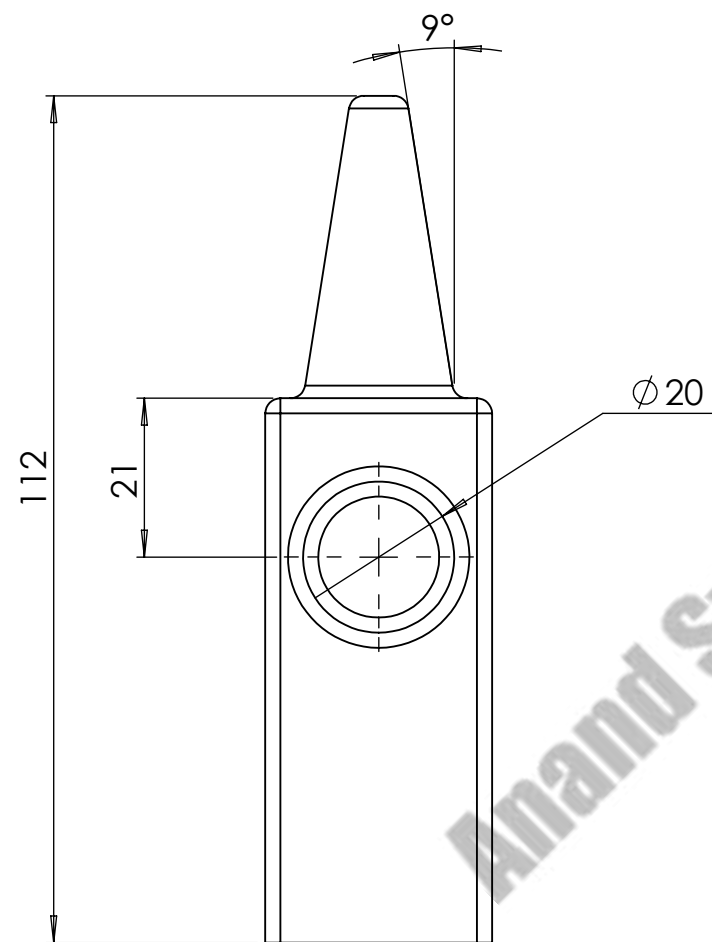

COMPANY NAME:



**ANAND SYSTEM
ENGINEERING PVT LTD**

Email id: info@anandcontrol.in

CONTACT NO: 9137620579

FINISH:

DO NOT SCALE DRAWING.

REVISION:

TITLE:

**END POWER FEED
M-TYPE 2D**

DWG NO.

DATE:

SIGNATURE:

DRAWN	SAURABH		
CHK'D			
APPV'D			
MFG			

MATERIAL:

WEIGHT:

SCALE:

SHEET: 1 OF 1

A

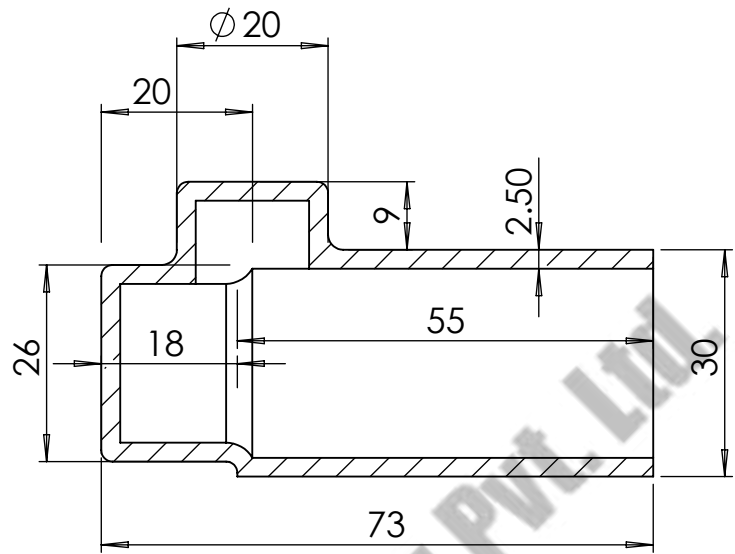
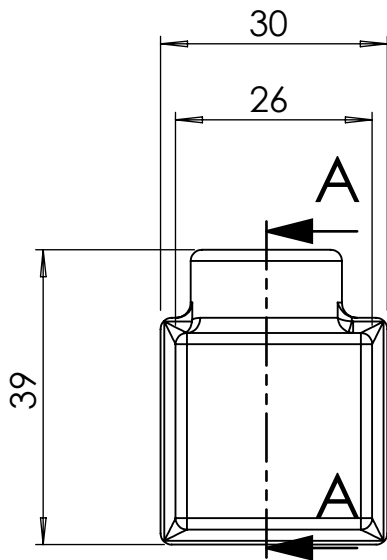

SECTION A-A

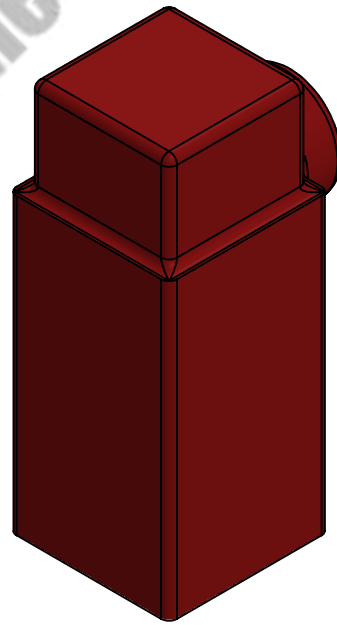

COMPANY NAME:



**ANAND SYSTEM
ENGINEERING PVT LTD**

DO NOT SCALE DRAWING.

REVISION:

TITLE:

**END COVER
M-TYPE 2D**

Email id: info@anandcontrol.in

CONTACT NO: 9137620579

FINISH:

DWG NO.

DATE:

SIGNATURE:

DRAWN	SAURABH
CHK'D	
APP'D	
MFG	

MATERIAL:

WEIGHT:

SCALE:

SHEET: 1 OF 1

A

4

3

2

1

F

F

E

E

D

D

C

C

B

B

A

A

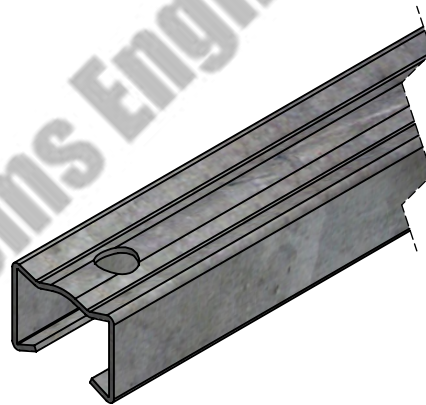
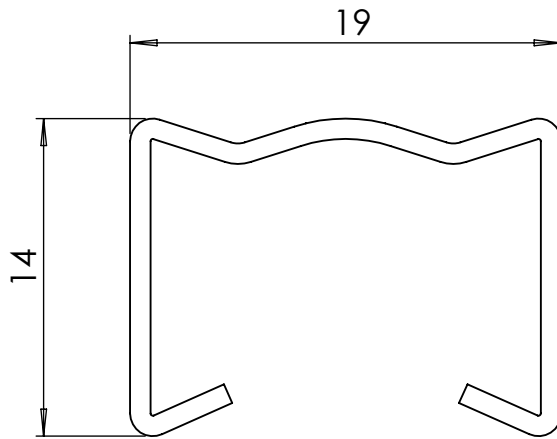

COMPANY NAME:



ANAND SYSTEM
ENGINEERING PVT LTD

Email id: info@anandcontrol.in

CONTACT NO: 9137620579

FINISH:

DO NOT SCALE DRAWING.

REVISION:

TITLE:

DSL BUSBAR GI
M-TYPE 2D

DWG NO.

DATE:

SIGNATURE:

A

DRAWN	SAURABH
CHK'D	
APP'D	
MFG	

MATERIAL:	
WEIGHT:	

SCALE: SHEET: 1 OF 1

4

3

2

1

4

3

2

1

F

F

E

E

D

D

C

C

B

B

A

A

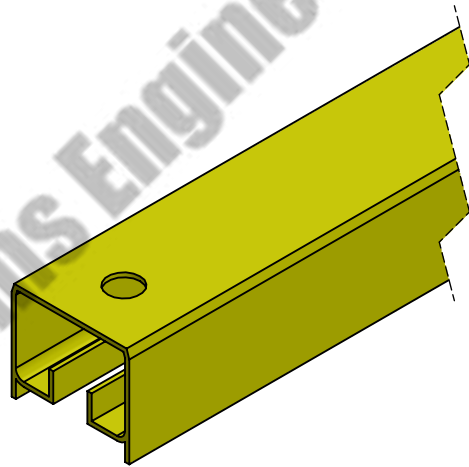
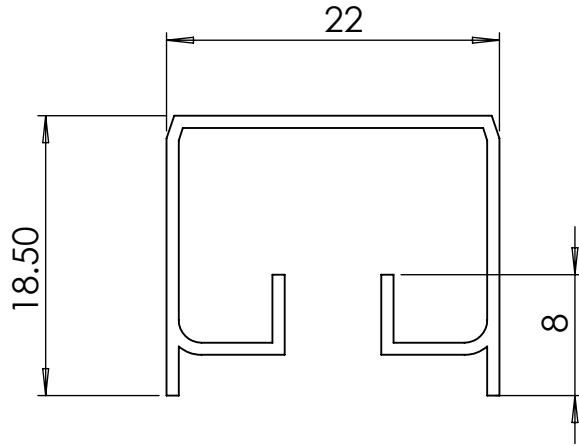

COMPANY NAME:



ANAND SYSTEM
ENGINEERING PVT LTD

Email id: info@anandcontrol.in

CONTACT NO: 9137620579

FINISH:

DO NOT SCALE DRAWING.

REVISION:

TITLE:

DSL BUSBAR
SLEEVE M-TYPE
2D

DWG NO.

DATE:

SIGNATURE:

A

DRAWN	SAURABH
CHK'D	
APP'D	
MFG	

MATERIAL: PVC

WEIGHT:

SCALE:

SHEET: 1 OF 1

4

3

2

1

4

3

2

1

F

F

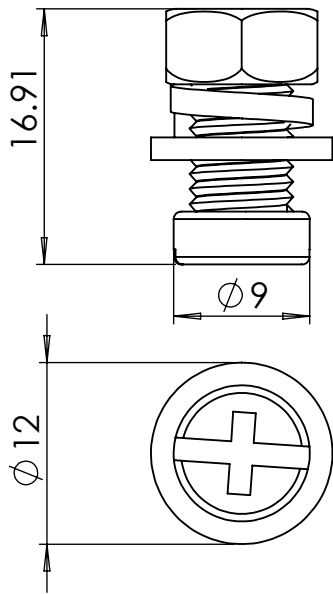

BOLT M6X10

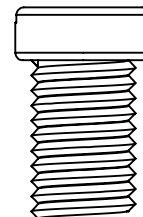

PLAIN WAHSER M6

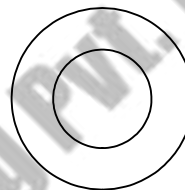

SPRING WAHSER M6

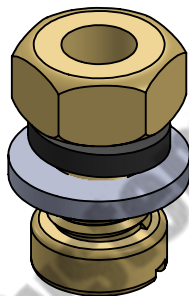
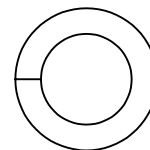

NUT M6

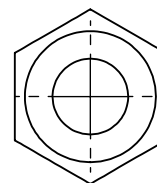

D

D

C

C

B

B

COMPANY NAME:



ANAND SYSTEM ENGINEERING PVT LTD

DO NOT SCALE DRAWING.

REVISION:

TITLE:

END POWER FEED ASSM M-TYPE 2D

Email id: info@anandcontrol.in

CONTACT NO: 9137620579

FINISH:

DWG NO.

DATE:

SIGNATURE:

A

A

DRAWN	SAURABH
CHK'D	
APP'D	
MFG	

MATERIAL:	
WEIGHT:	

SCALE:		SHEET: 1 OF 1
--------	--	---------------

4

3

2

1

4

3

2

1

F

F

E

E

D

D

C

C

B

B

A

A

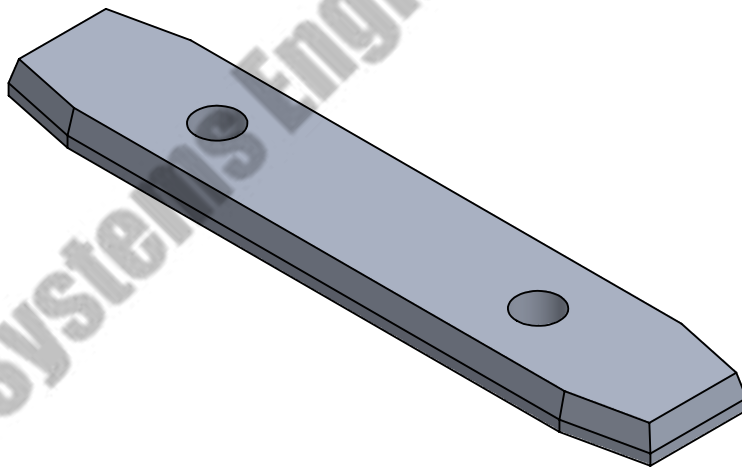
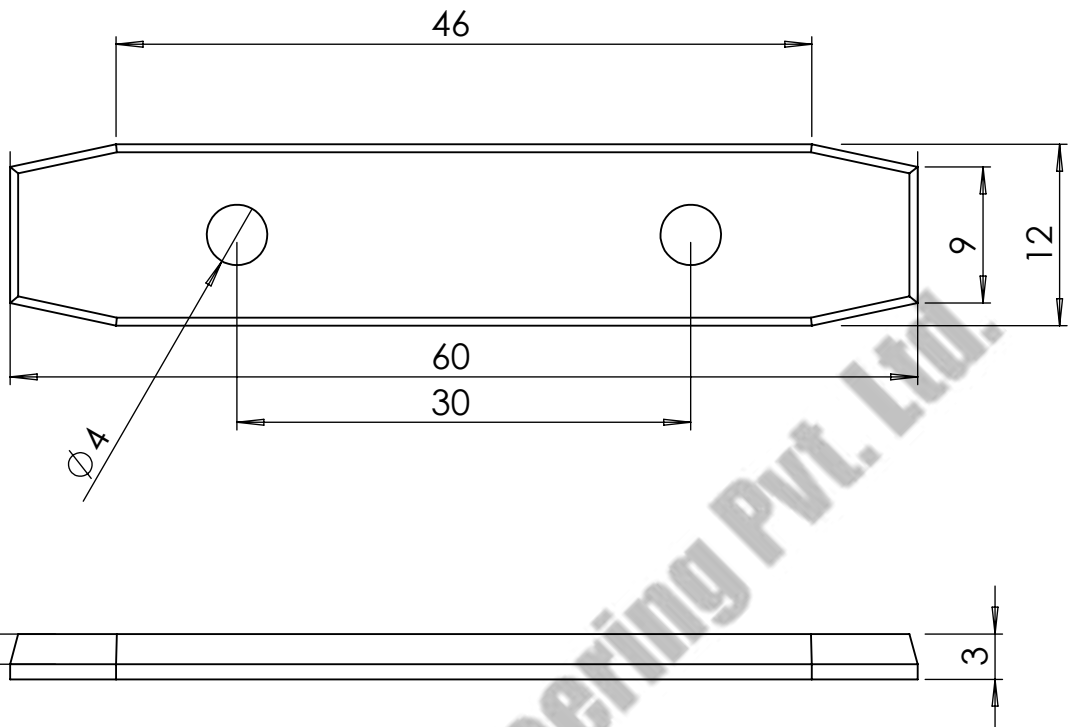

COMPANY NAME:



ANAND SYSTEM
ENGINEERING PVT LTD

Email id: info@anandcontrol.in

CONTACT NO: 9137620579

FINISH:

DO NOT SCALE DRAWING.

REVISION:

TITLE:

JOINING PIN
ALU M-TYPE
2D

DWG NO.

DATE:

SIGNATURE:

A

DRAWN

SAURABH

CHK'D

APP'D

MFG

MATERIAL:

WEIGHT:

SCALE:

SHEET: 1 OF 1

4

3

2

1

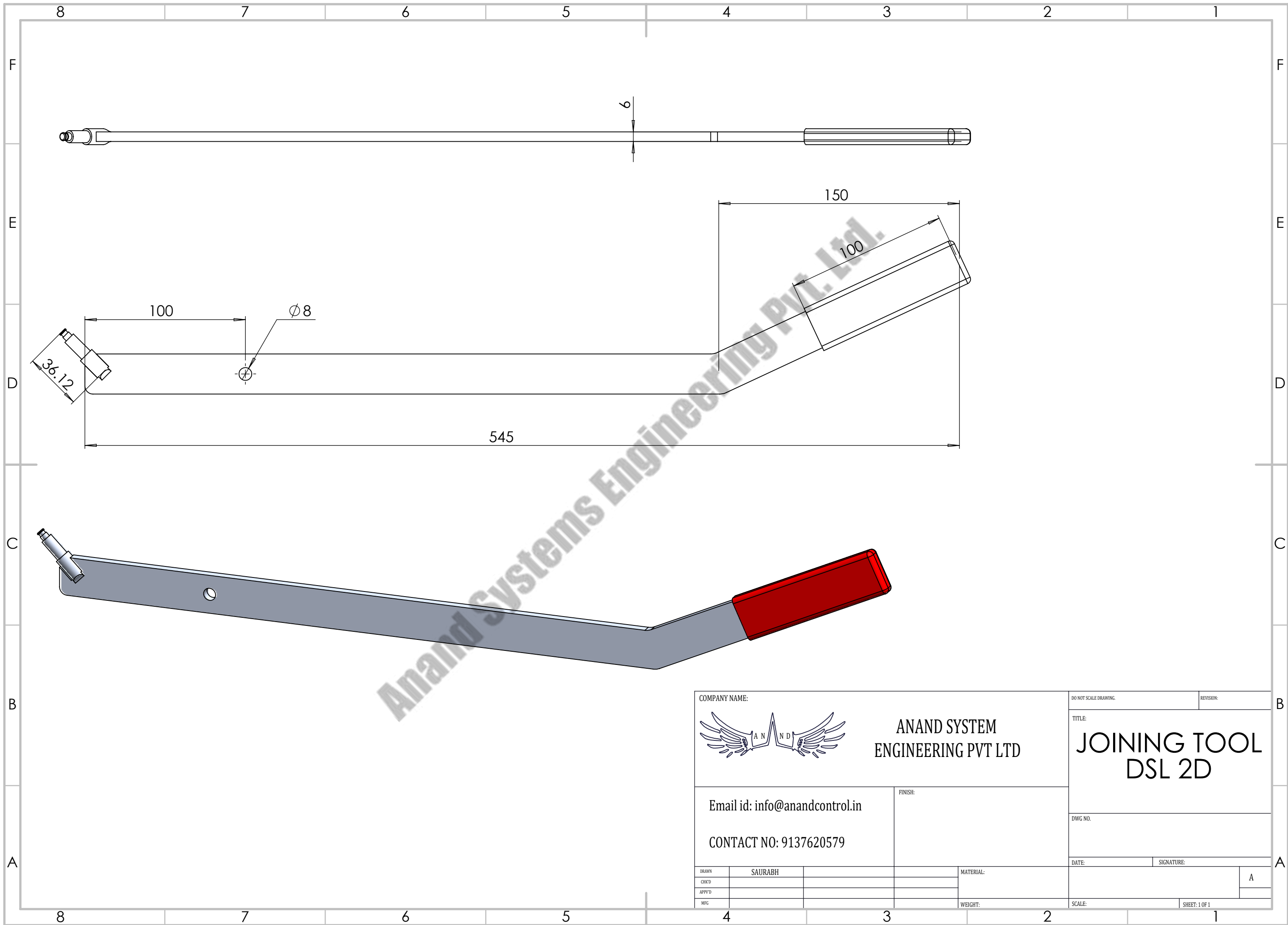

Anand Systems Engineering Pvt. Ltd.

COMPANY NAME:		ANAND SYSTEM ENGINEERING PVT LTD		DO NOT SCALE DRAWING.	REVISION:
		Email id: info@anandcontrol.in CONTACT NO: 9137620579		TITLE: <h1 style="text-align: center;">JOINING TOOL DSL 2D</h1>	
FINISH:		MATERIAL:		DWG NO.	
DATE:		SIGNATURE:		A	
DRAWN	SAURABH			SCALE:	
CHK'D				SHEET: 1 OF 1	
APP'VD					
MFG					

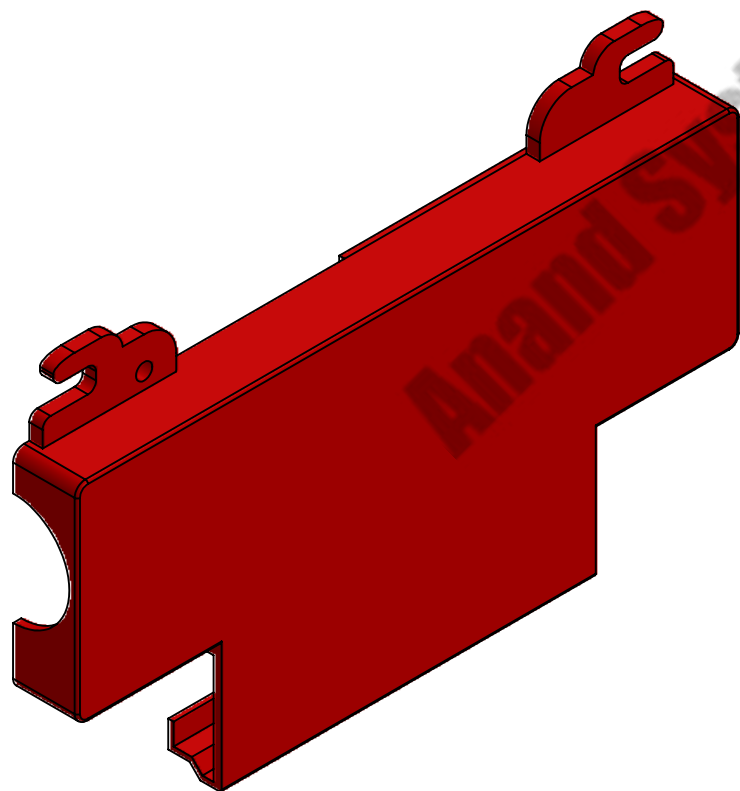
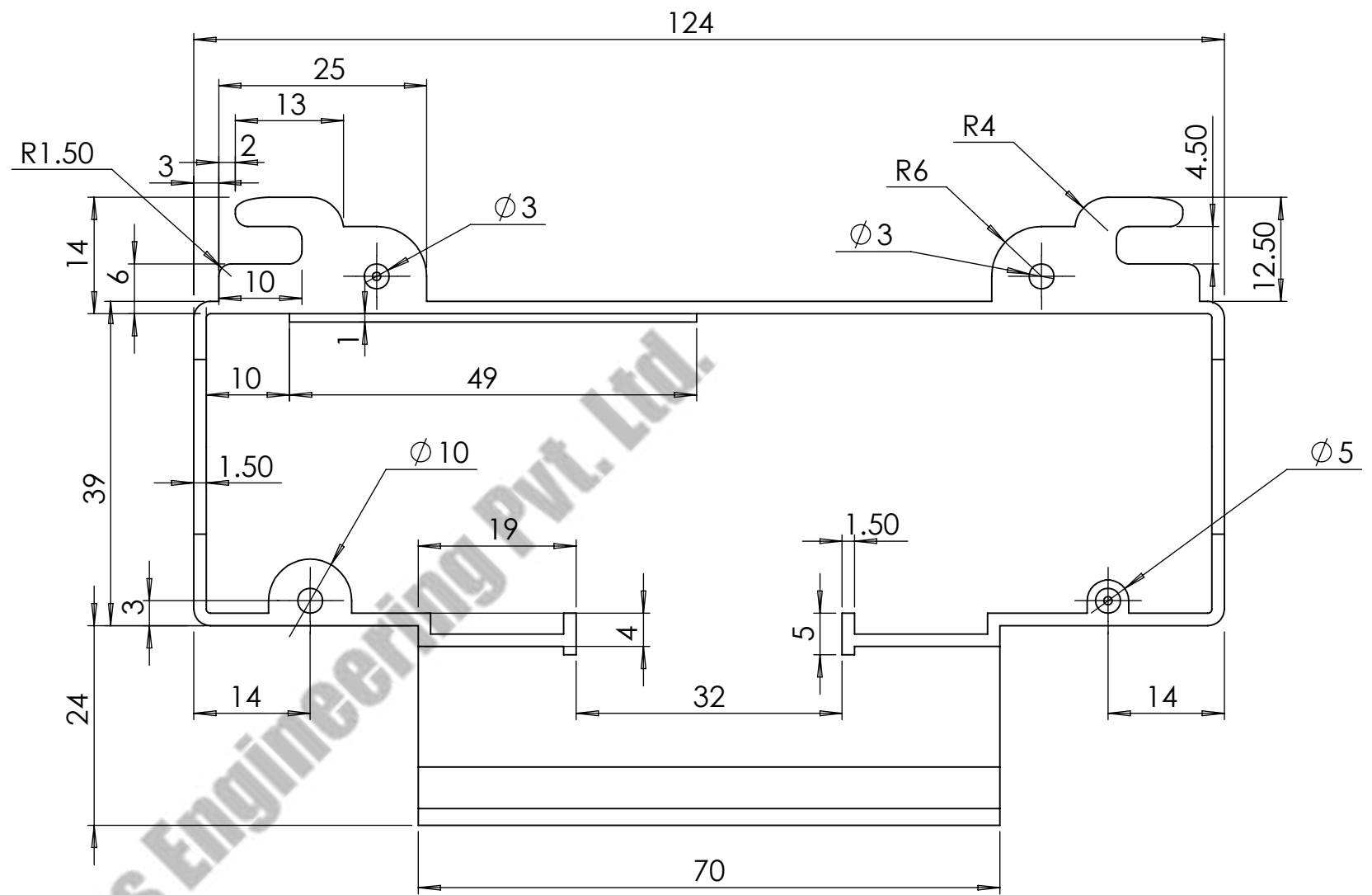
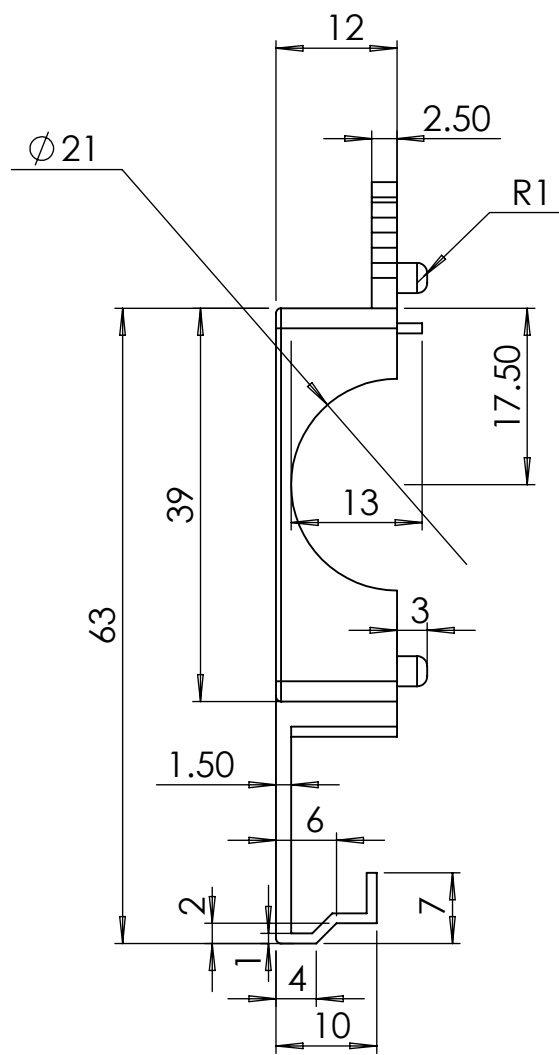

COMPANY NAME:		ANAND SYSTEM ENGINEERING PVT LTD		DO NOT SCALE DRAWING.	REVISION:
		<p>ANAND SYSTEM ENGINEERING PVT LTD</p>		TITLE: MOULDING CENTRE POWER FEED COVER M-TYPE 2D	
Email id: info@anandcontrol.in		FINISH:		DWG NO.	
CONTACT NO: 9137620579				DATE:	
DRAWN	SAURABH			SIGNATURE:	
CHK'D				A	
APPY'D					
MFG				SCALE:	
		WEIGHT:		SHEET: 1 OF 1	

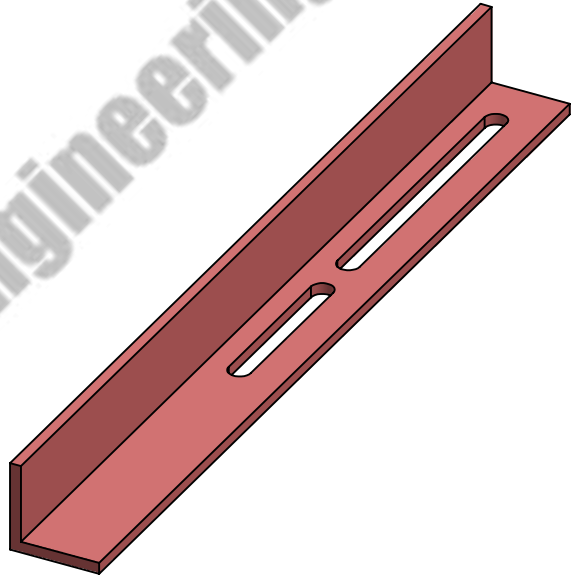
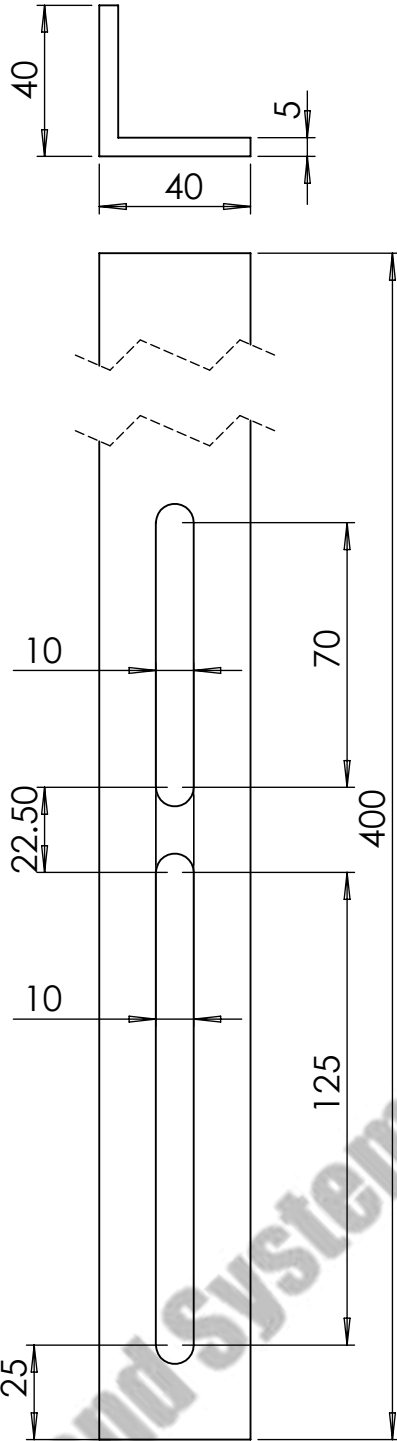

40X40X400, THK-5
MM

COMPANY NAME:



ANAND SYSTEM
ENGINEERING PVT LTD

DO NOT SCALE DRAWING.

REVISION:

TITLE:

Web-Bracket
M-TYPE 2D

Email id: info@anandcontrol.in

CONTACT NO: 9137620579

FINISH:

DWG NO.

DATE:

SIGNATURE:

DRAWN	SAURABH
CHK'D	
APP'D	
MFG	

MATERIAL:

WEIGHT:

SCALE:

SHEET: 1 OF 1

A