

EXPLODED VIEW

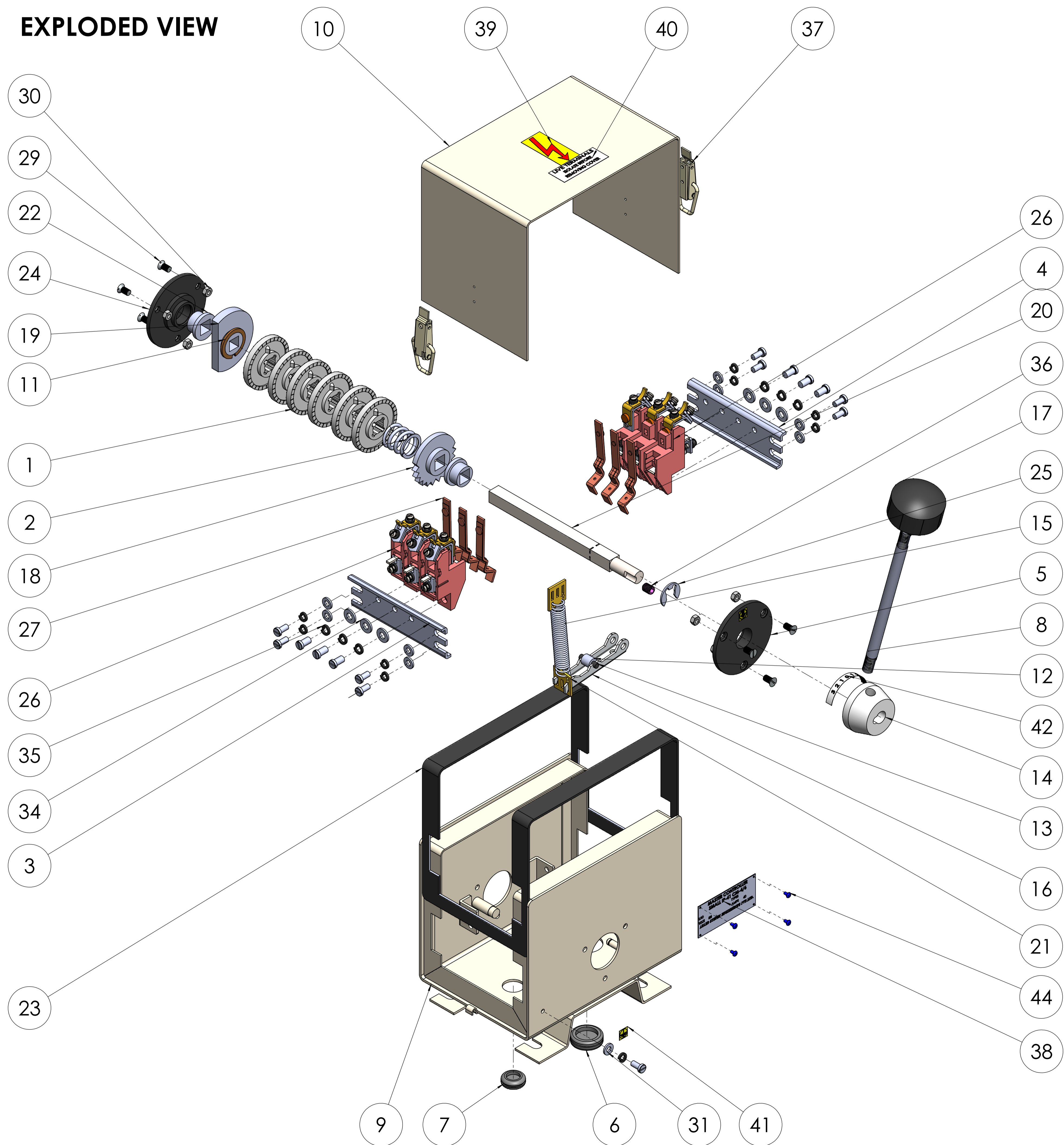

ITEM NO.	PART NAME	DESCRIPTION	Material	QTY.
1	CAM	SPARE CAM	NYLON	6
2	COMPRESSING SPRING 4-6	SHAFT & CAM FIXING	SPRING STEEL	1
3	CONTACT STRIP	LEFT SIDE CONTACT FIXING STRIP 3 HOLES	M.S.	1
4	CONTACT STRIP	RIDE SIDE CONTACT FIXING STRIP 4 HOLES	M.S.	1
5	END BUSH	END BUSH OPEN	NYLON	1
6	GRUMET	GRUMET 1"	RUBBER	1
7	GRUMET 3-4 4-6	GRUMET 3/4"	RUBBER	1
8	HANDLE ROD	MS HUB HANDLE ROD	MS	1
9	HOUSING	HOUSING IP-41 1/3 CM	SHEET METAL	1
10	TOP COVER	HOUSING TOP COVER IP-41 1/3 CM	SHEET METAL	1
11	LOCK WASHER	12X12 SQ 29X1.5MM	M.S.	1
12	ROLLER	10X5X10MM ROLLER	M.S.	1
13	PIN	5X20 MM ROLLER PIN	M.S.	1
14	HUB	12X45X25 MM MS HUB	M.S.	1
15	SPRING	NOTCHING SPRING	SPING STEEL	1
16	NOTCHING LEVER 4-6	80X15 MM	M.S.	1
17	KNOB	PLATIC KNOB	NYLON 6	1
18	RATCHET WHEEL	PLASTIC RATCHET WHEEL 18"	M.S.	1
19	PLASTIC STOPER	22X12X8MM	NYLON	1
20	SHAFT	12X12X180 SQ	M.S.	1
21	SPRING HOLDER 4-6	SPRING FITTING	M.S.	2
22	SQUARE BUSH 4-6	20X25X13MM , 12X12 MM SQ	NYLON 6	2
23	GASKET PATTI	BODY FIXING	RUBBER	1
24	END BUSH CLOSED 4-6	20X25X 35X70 X4MM	NYLON	1
25	E TYPE CIRCLIP	E CIRCLIP 11.5 MM, GEAR SHAFT	M.S.	1
26	CONTACT BLOCK	CONTACT BLOCK ASSEMBLY IP-4140AMP	-	6
27	CONTACT STRIP	CONTACT BREAK STRIP	BRASS	6
28	CSK SCREW 5X10 4-6	CHEESED 5X10	M.S.	9
29	SCREW CSK	END BUSH 5X10 CSK	M.S.	6
30	HEX NUT	M5	M.S.	6
31	PLAIN WASHER	11X5.5X1.5	M.S.	9
32	SPRING WASHER	WASHER A5	SPRING STEEL	9
33	CHEESED SCREW	CHEESED SCREW M6X10	M.S.	6
34	PLAIN WASHER	13X6.5X1.5 PLAIN WASHER M6	M.S.	6
35	SPRING WASHER	WASHER A6	SPRING STEEL	6
36	GRUB SCREW	8X10 MM M8 THREAD	M.S.	1
37	LOCK	HOUSING LOCK	M.S.	2
38	NAME PLATE	71X33X0.5 (4 HOLES 2MM)	ALUMINIUM	1
39	ARROW STICKER 4-6	ARROW STICKER	-	1
40	TERMINAL STICKER 4-6	TERMINAL STICKER	-	1
41	ERTHING STICKER 4-6	ERTHING STICKER	-	1
42	STEP LONG STCIKER 4-6	STEP LONG STICKER	-	1
43	STICKER 4-6	DOWN ARROW STICKER	-	1
44	RIVET AB4 4-6	NAME PLATE FIXING	ALUMINIUM	4

COMPANY NAME: **ANAND SYSTEM ENGINEERING PVT LTD**

TITLE: **MASTER CONTROLLER SMALL IP-41 4-6 ASSEMBLY 2D**

Email id: info@anandcontrol.in

CONTACT NO: [9137620579](tel:9137620579)

DO NOT SCALE DRAWING

SCALE: 1:2

SHEET 1 OF 2

FRONT VIEW

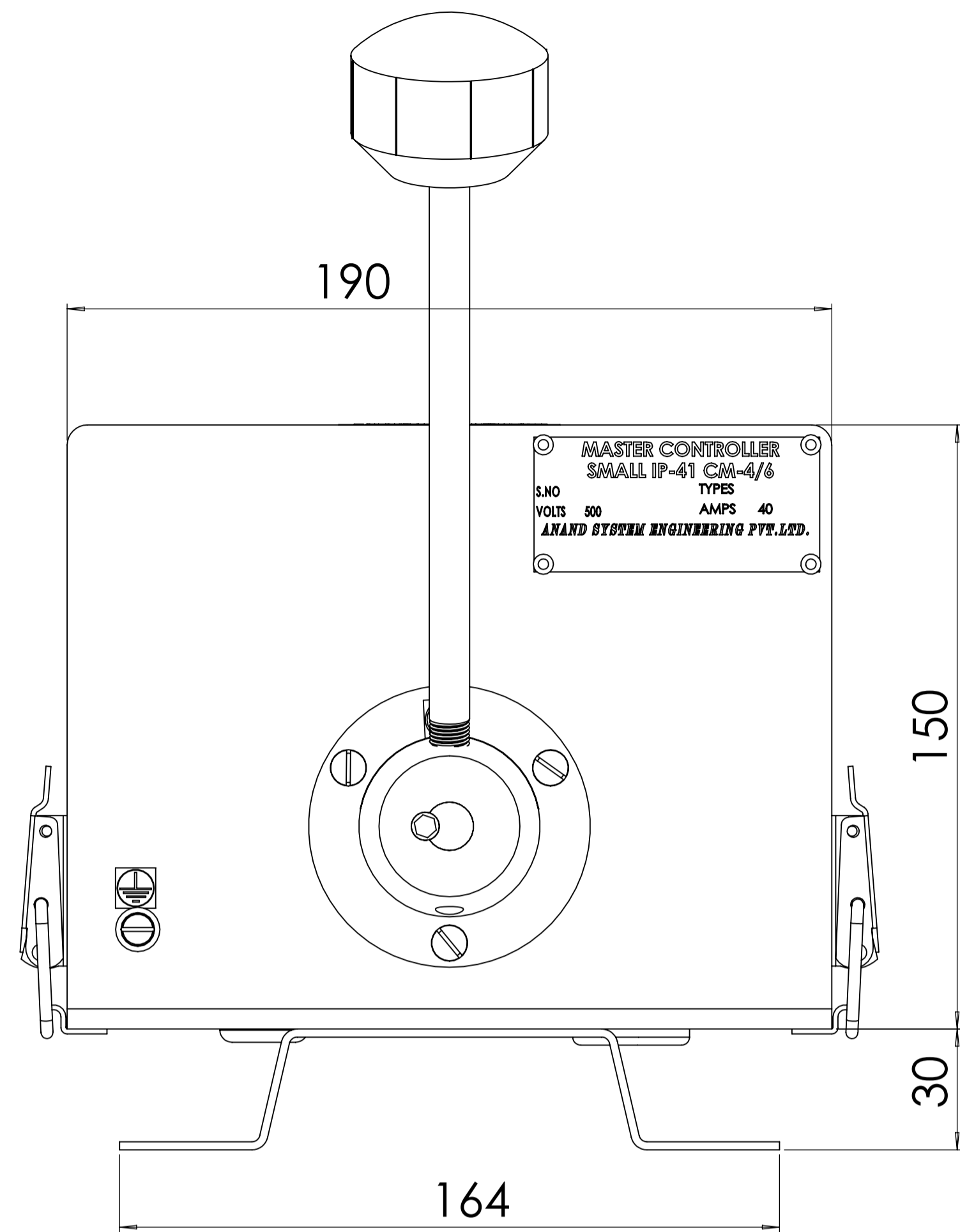

SIDE VIEW

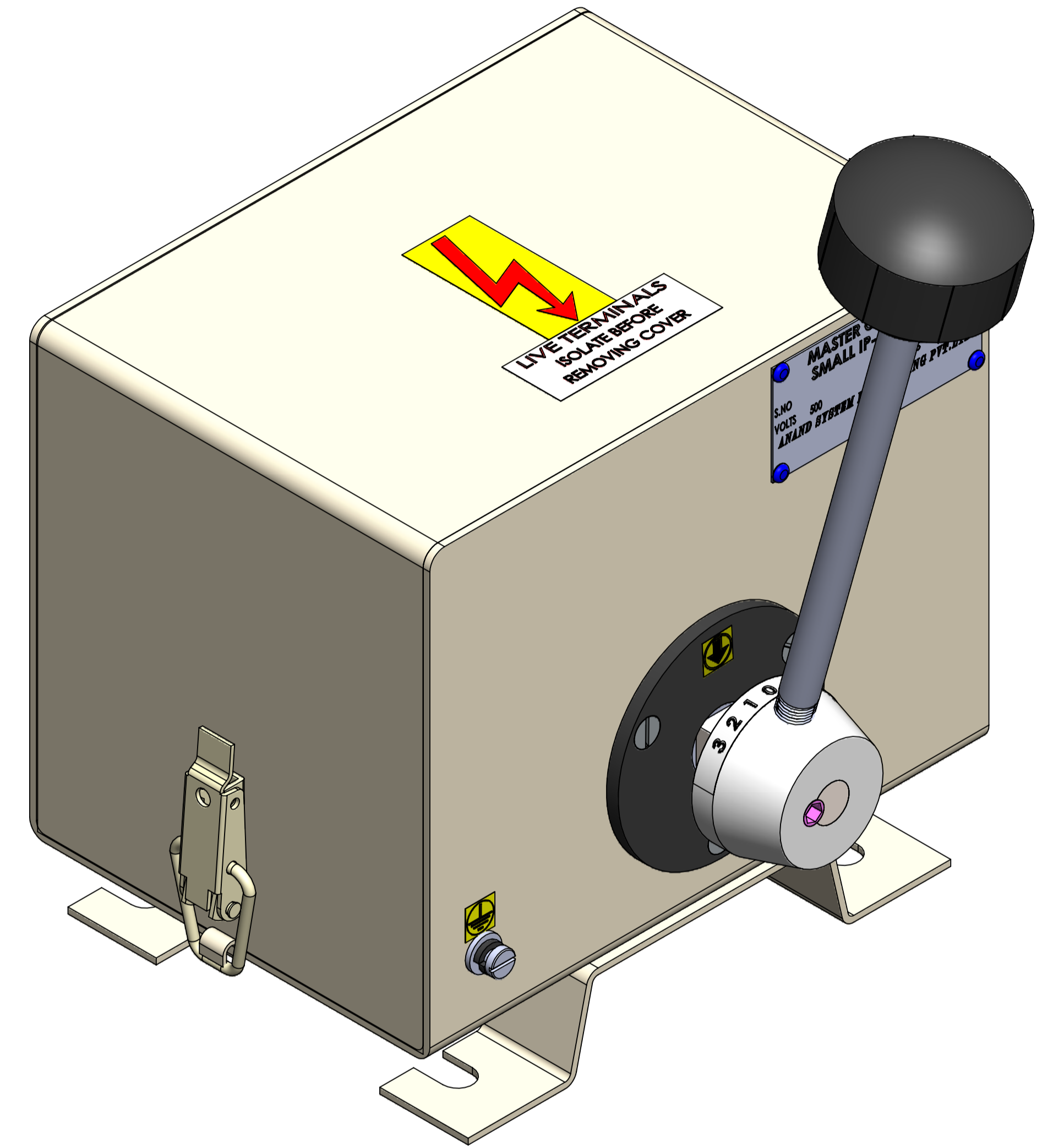
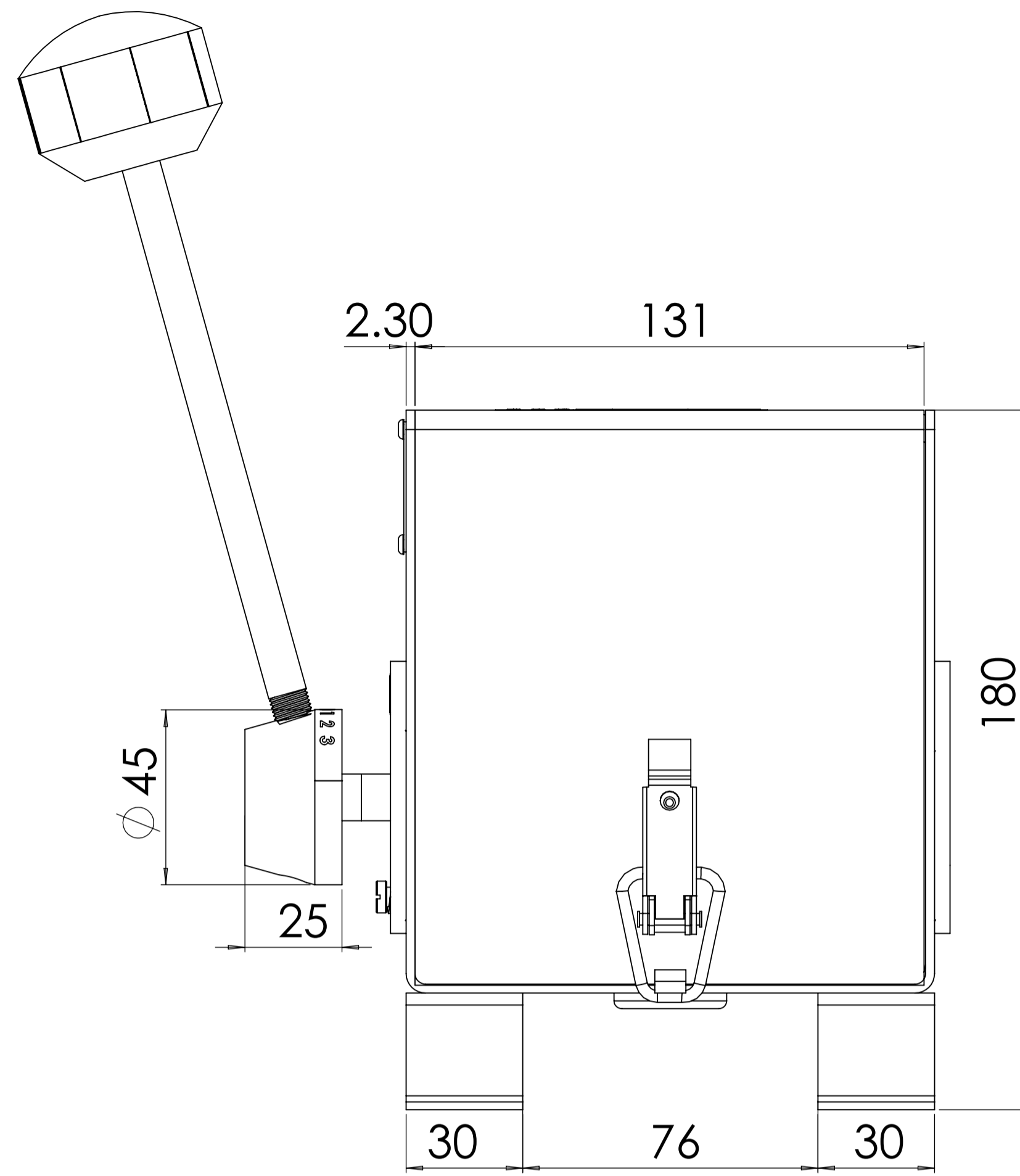

TOP VIEW

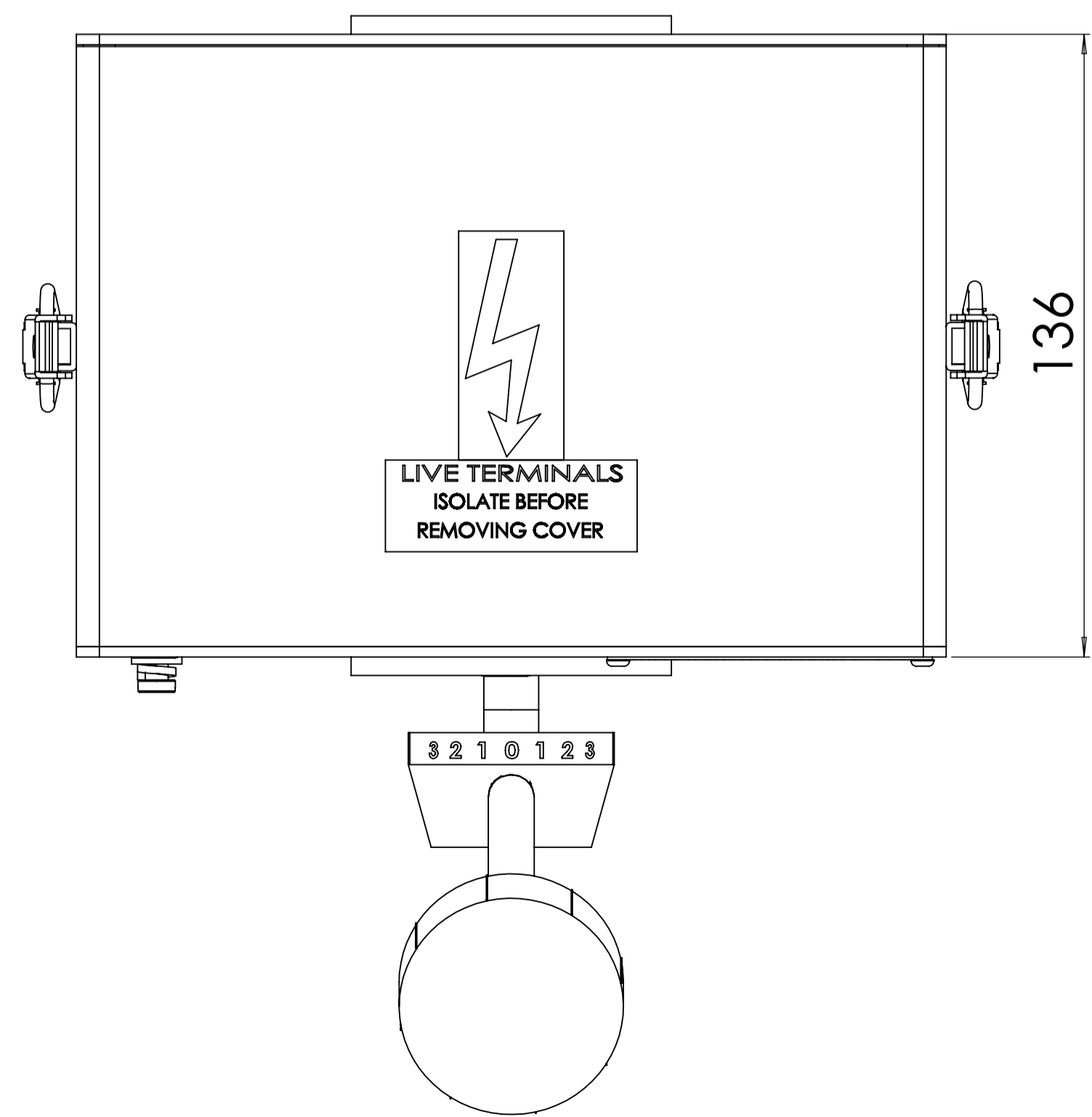

BOTTOM VIEW

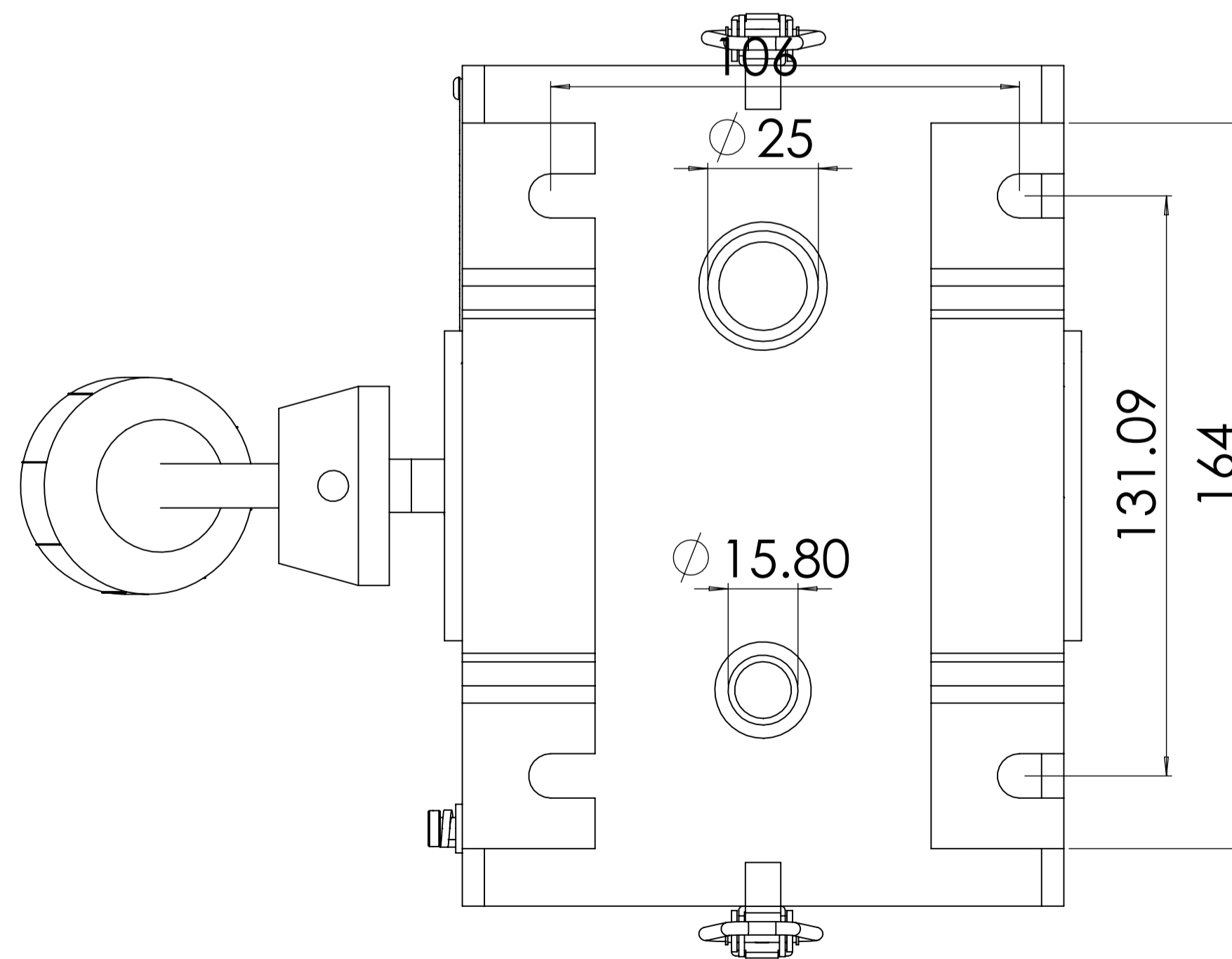

COMPANY NAME:		ANAND SYSTEM ENGINEERING PVT LTD		DO NOT SCALE DRAWING	REVISION
Email id: info@anandcontrol.in		CONTACT NO: 9137620579		TITLE: MASTER CONTROLLER SMALL IP-41 4-6 ASSEMBLY 2D	
DRAWN:	CHKD:	APPRD:	Q.A:	DATE:	SIGNATURE:
SCALE: 1:2				SHEET 2 OF 2	