

EXPLODED VIEW

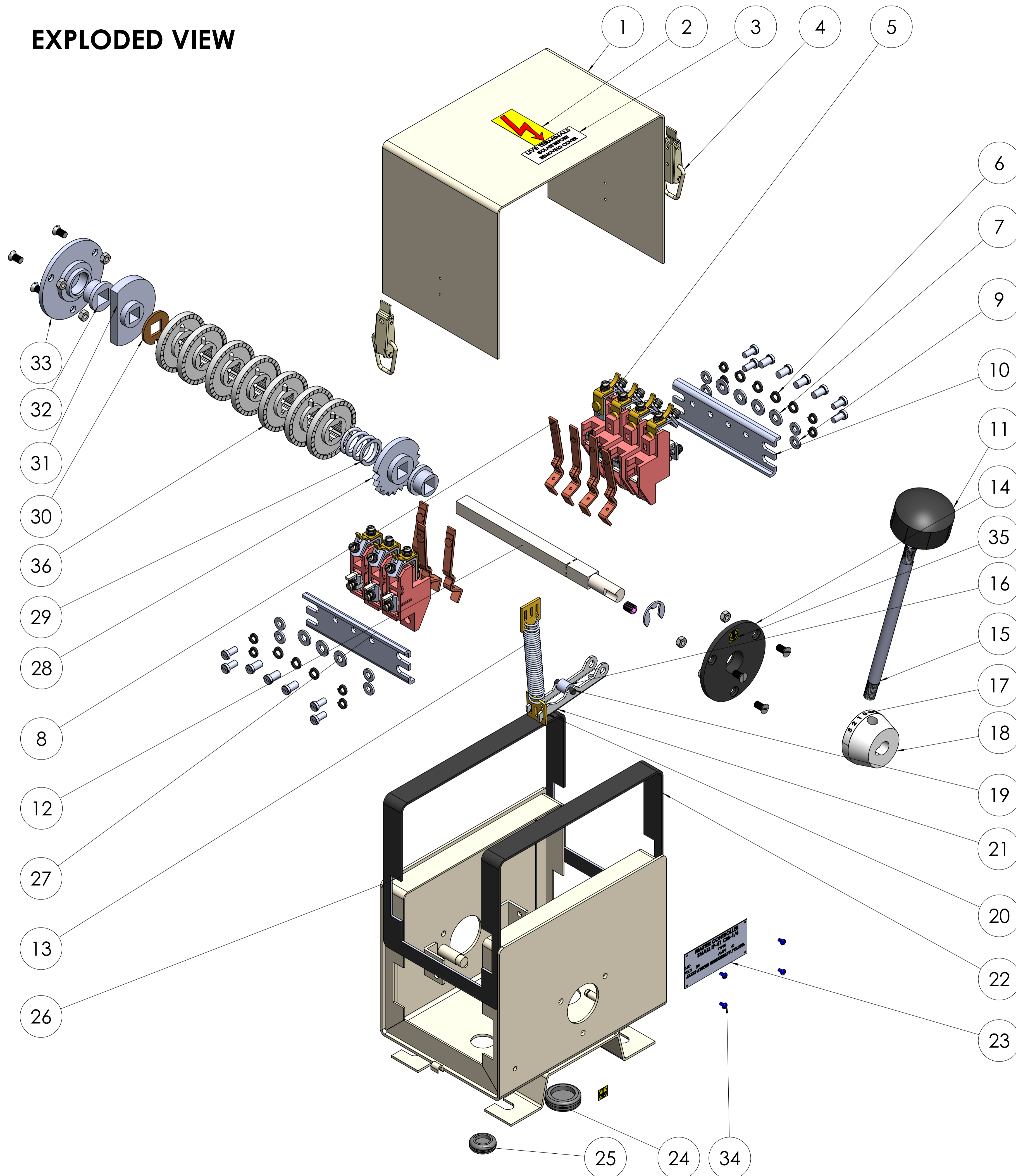

ITEM NO.	PART NUMBER	DESCRIPTION	Material	QTY.
1	TOP COVER	HOUSING TOP COVER IP-41 1/3 CM	SHEET METAL	1
2	ARROW STICKER 1-4	ARROW STICKER	-	1
3	TERMINAL STICKER 1-4	TERMINAL STICKER	-	1
4	LOCK	HOUSING LOCK	M.S.	2
5	CONTACT BLOCK	CONTACT BLOCK ASSEMBLY IP-41 40AMP	-	7
6	SPRING WASHER	WASHER A6	SPRING STEEL	7
7	PLAIN WASHER	13X6.5X1.5 PLAIN WASHER M6	M.S.	7
8	CONTACT STRIP	CONTACT BREAK STRIP	BRASS	7
9	PLAIN WASHER	11X5.5X1.5	M.S.	8
10	CONTACT STRIP	RIDE SIDE CONTACT FIXING STRIP 4 HOLES	M.S.	1
11	KNOB	PLATIC KNOB	NYLON 6	1
12	SHAFT	12X12X180 SQ	M.S.	1
13	SPRING	NOTCHING SPRING	SPING STEEL	1
14	END BUSH	END BUSH OPEN	NYLON	1
15	HANDLE ROD	MS HUB HANDLE ROD	MS	1
16	ROLLER	10X5X10MM ROLLER	M.S.	1
17	STEP LONG STICKER 1-4	STEP LONG STICKER	-	1
18	HUB	12X45X25 MM MS HUB	M.S.	1
19	PIN	5X20 MM ROLLER PIN	M.S.	1
20	SPRING HOLDER 1-4	SPRING FITTING	M.S.	2
21	NOTCHING LEVER 1-4	80X15 MM	M.S.	1
22	GASKET PATTI	BODY FIXING	RUBBER	1
23	NAME PLATE	71X33X0.5 (4 HOLES 2MM)	ALUMINIUM	1
24	GRUMET	GRUMET 1"	RUBBER	1
25	GRUMET 3-4 1-4	GRUMET 3/4"	RUBBER	1
26	HOUSING	HOUSING IP-41 1/3 CM	SHEET METAL	1
27	CONTACT STRIP	LEFT SIDE CONTACT FIXING STRIP 3 HOLES	M.S.	1
28	RATCHET WHEEL	PLASTIC RATCHET WHEEL 18"	M.S.	1
29	COMPRESSING SPRING 1-4	SHAFT & CAM FIXING	SPRING STEEL	1
30	LOCK WASHER	12X12 SQ 29X1.5MM	M.S.	1
31	PLASTIC STOPER	22X12X8MM	NYLON	1
32	SQUARE BUSH 1-4	20X25X13MM , 12X12 MM SQ	NYLON 6	2
33	END BUSH CLOSED 1-4	20X25X 35X70 X4MM	NYLON	1
34	RIVET AB4 1-4	NAME PLATE FIXING	ALUMINIUM	4
35	STICKER 1-4	DOWN ARROW STICKER	-	1
36	CAM	SPARE CAM	NYLON	7
37	E TYPE CIRCLIP	E CIRCLIP 11.5 MM, GEAR SHAFT	M.S.	1
38	CSK SCREW 5X10 1-4	CHEESED 5X10	M.S.	8
39	CHEESED SCREW	CHEESED SCREW M6X10	M.S.	7
40	SCREW CSK	END BUSH 5X10 CSK	M.S.	6
41	HEX NUT	M5	M.S.	6
42	SPRING WASHER	WASHER A5	SPRING STEEL	8
43	GRUB SCREW	8X10 MM M8 THREAD	M.S.	1
44	ERTHING STICKER 1-4	ERTHING STICKER	-	1

COMPANY NAME: **ANAND SYSTEM ENGINEERING PVT LTD**

EMAIL ID: info@anandcontrol.in

CONTACT NO: [9137620579](tel:9137620579)

TITLE: **MASTER CONTRFOLLER SMALL IP-41 CM 1-4 2D**

SCALE: 1:15

SHEET 1 OF 2

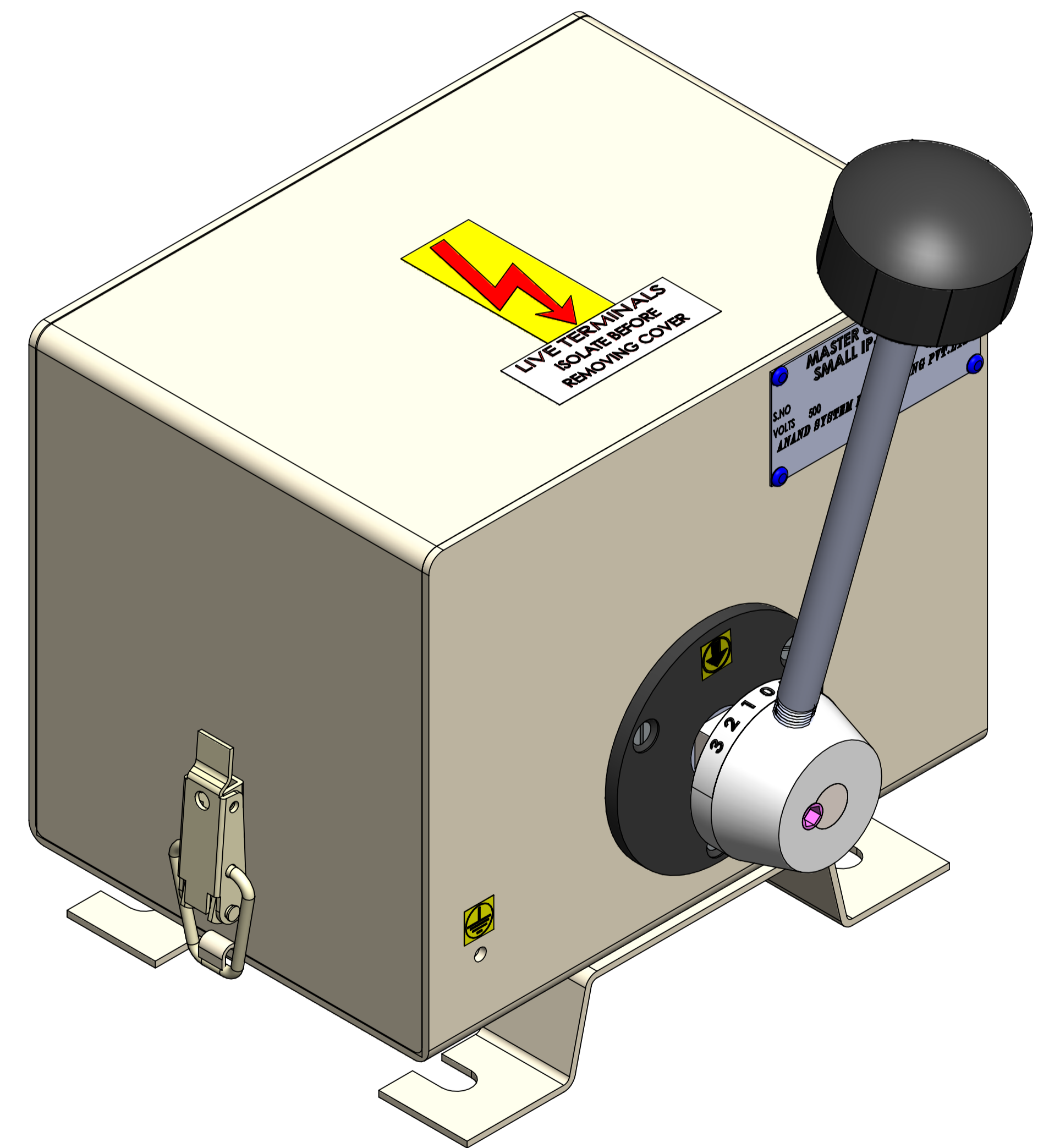
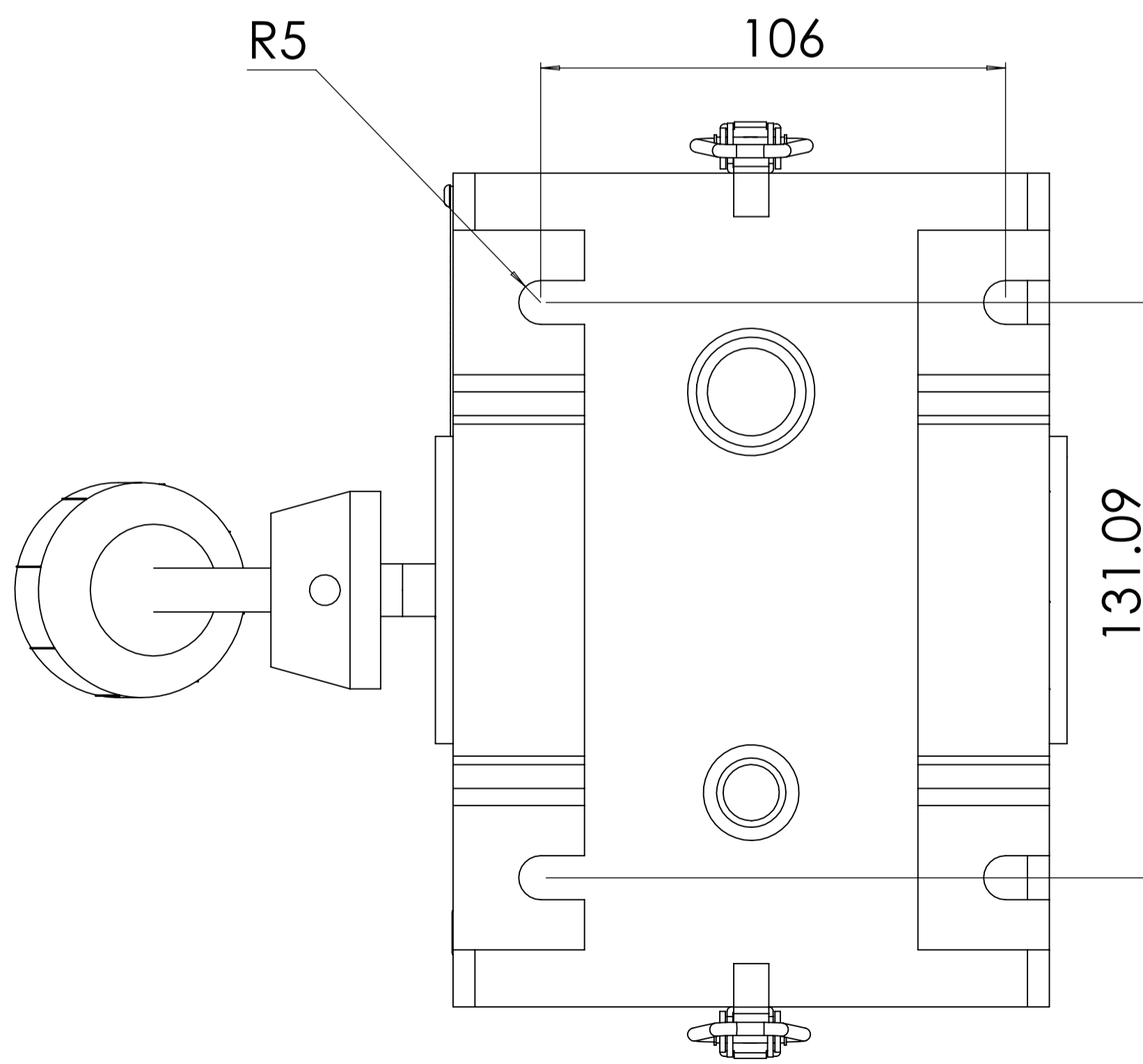
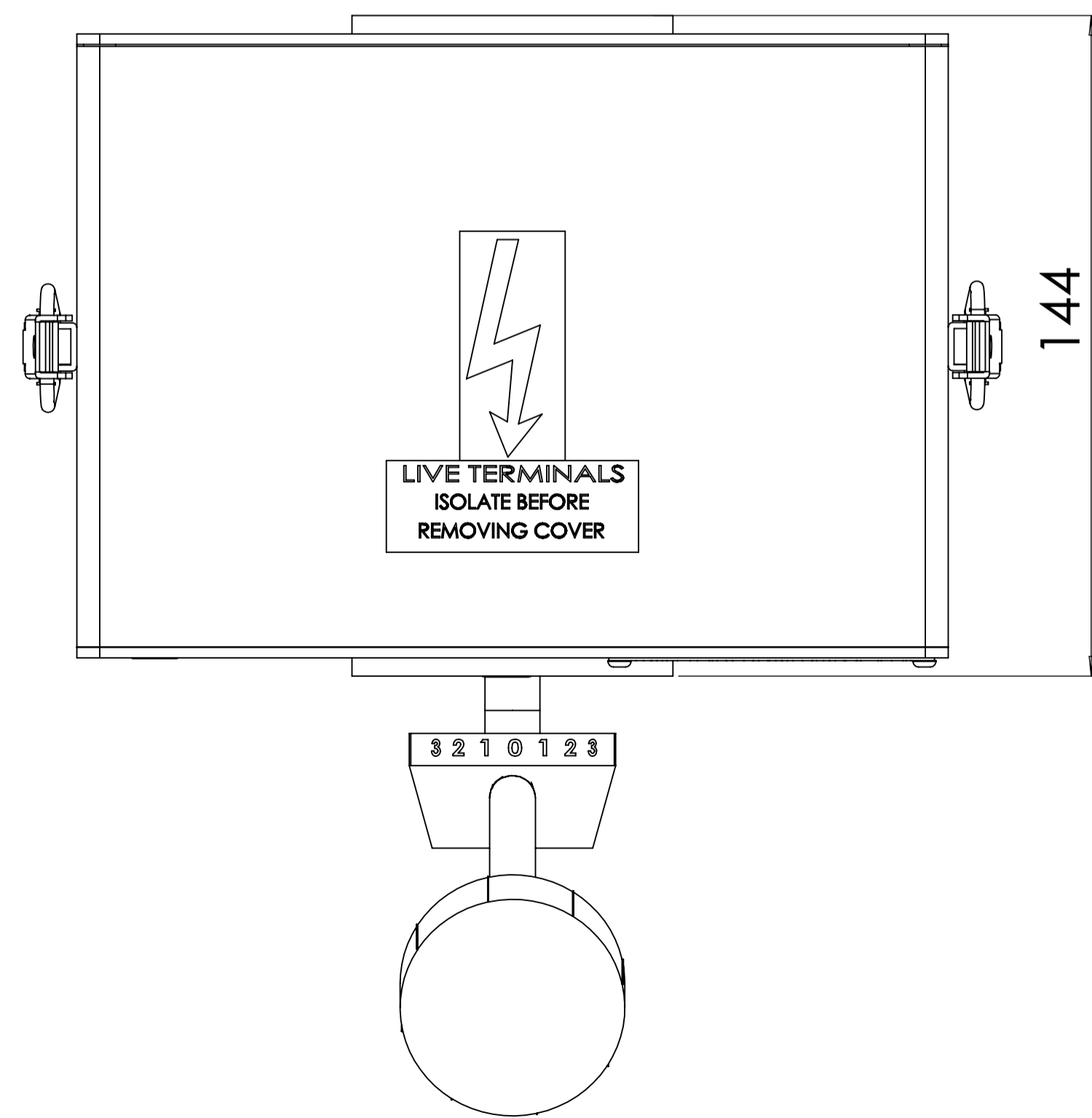
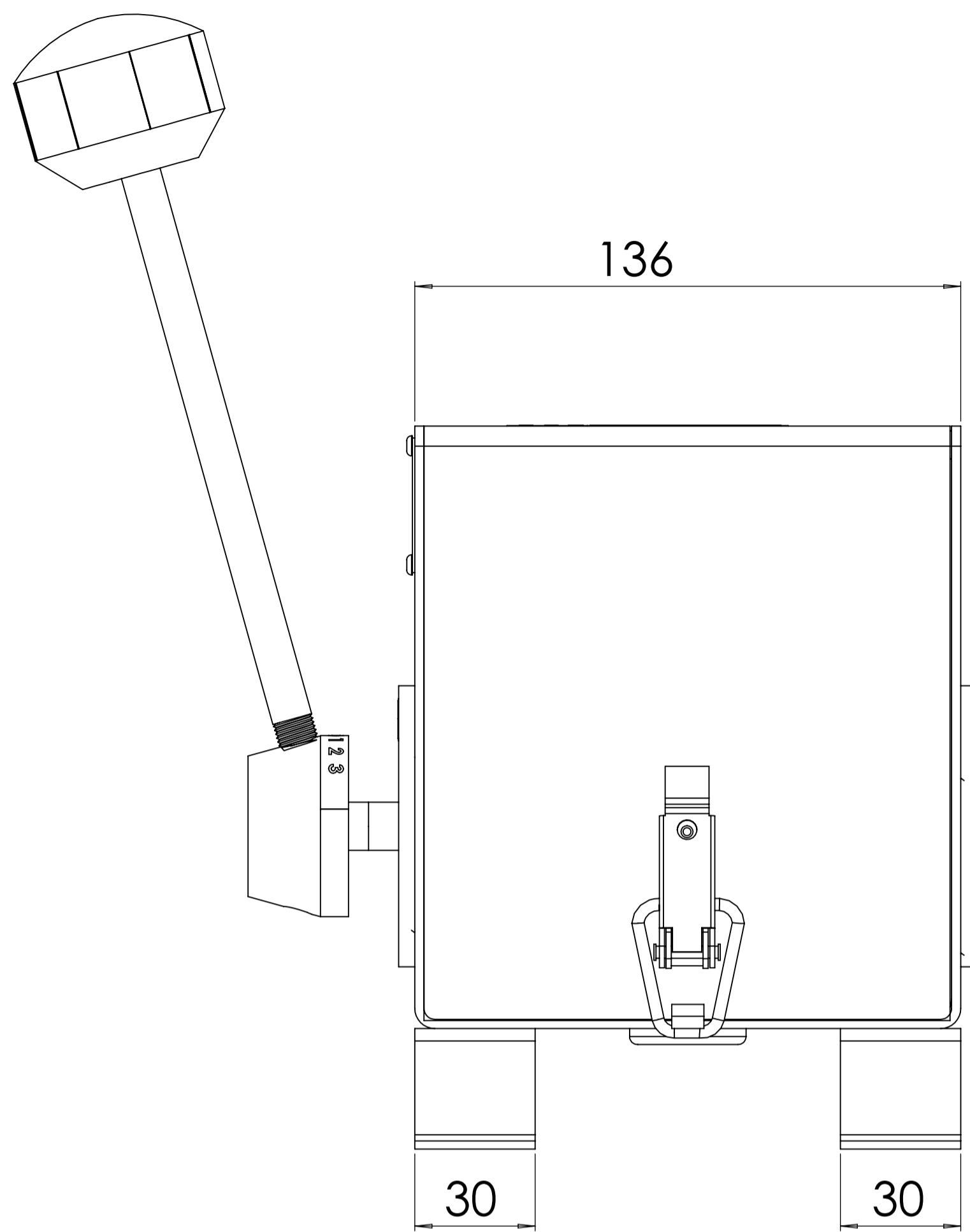
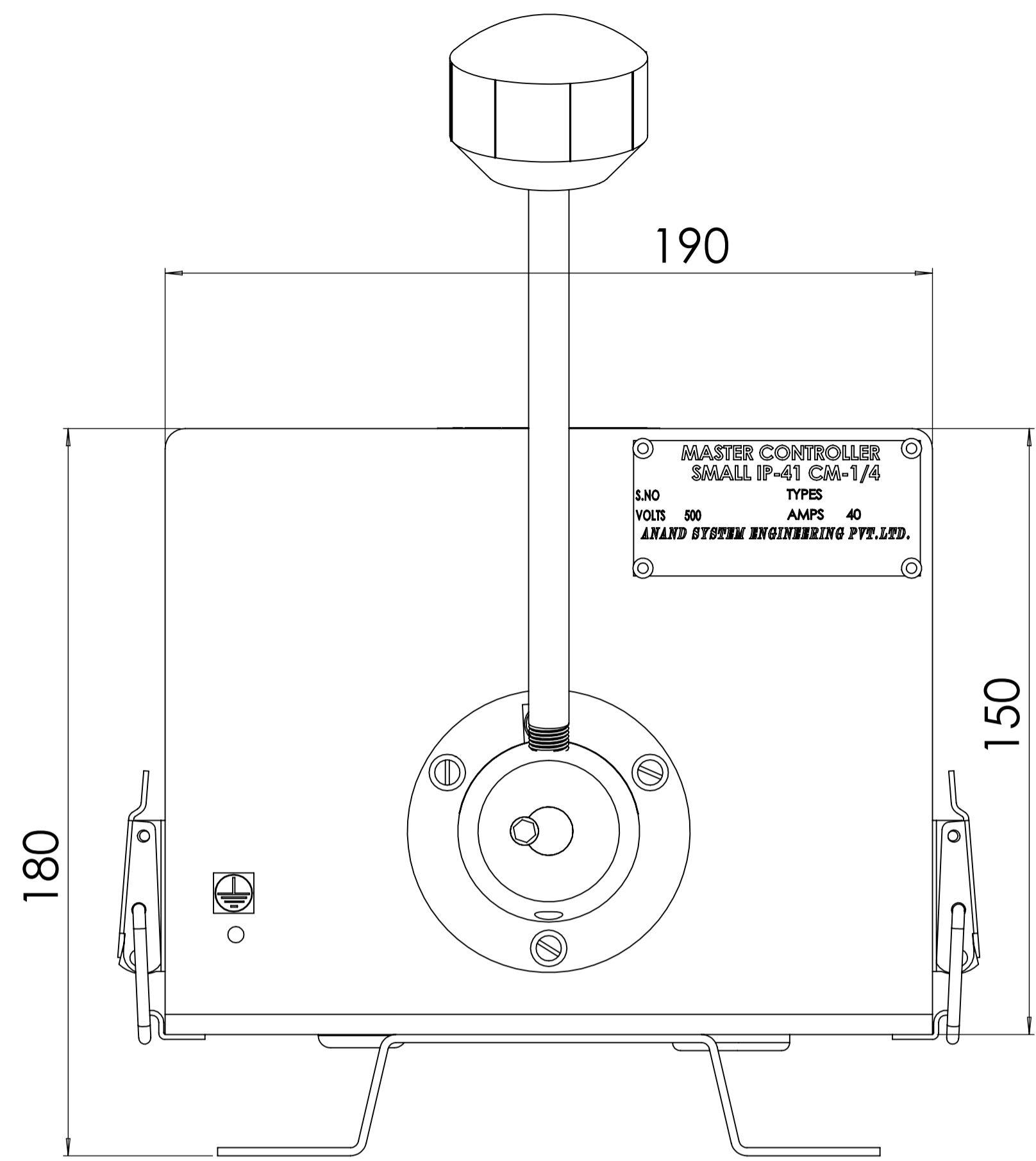

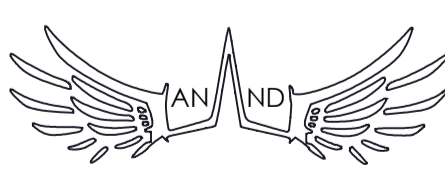
COMPANY NAME:		ANAND SYSTEM ENGINEERING PVT LTD		DO NOT SCALE DRAWING	REVISION
		ANAND SYSTEM ENGINEERING PVT LTD		TITLE: MASTER CONTROLLER SMALL IP-41 CM 1-4 2D	
Email id: info@anandcontrol.in		CONTACT NO: 9137620579		DWG NO. DATE SIGNATURE	
DRAWN: CHKD: APPVD: G.A.	MATERIAL: WEIGHT:	SCALE: 1:1.5	SHEET 2 OF 2	A1	