

# EXPLODED VIEW

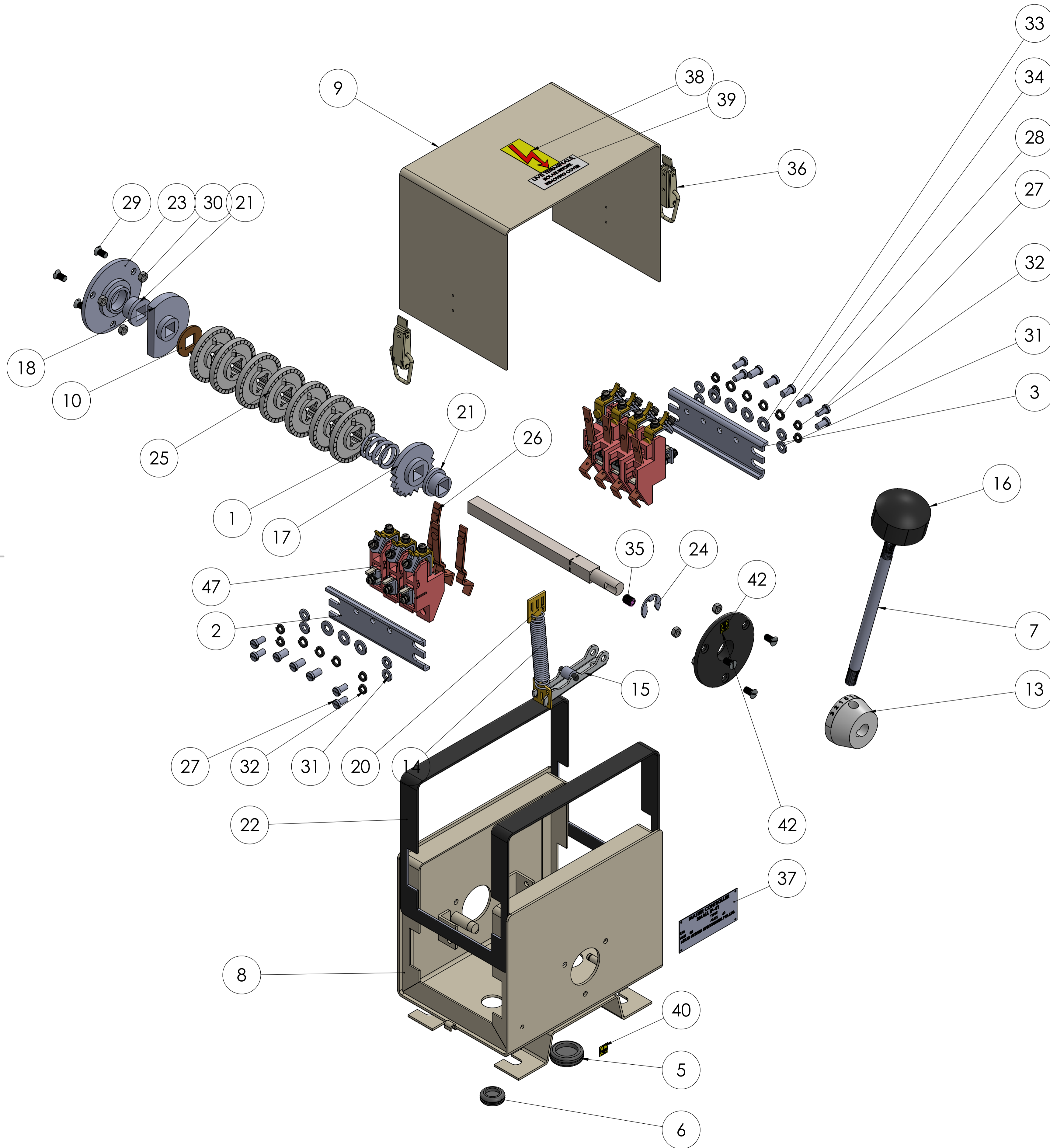

ITEM NO.	PART NUMBER	DESCRIPTION	MATERIAL	QTY.
1	COMPRESSING SPRING	SHAFT & CAM FIXING	SPRING STEEL	1
2	CONTACT STRIP	LEFT SIDE CONTACT FIXING STRIP 3 HOLES	M.S.	1
3	CONTACT STRIP	RIDE SIDE CONTACT FIXING STRIP 4 HOLES	M.S.	1
4	END BUSH	END BUSH OPEN	NYLON	1
5	GRUMET	GRUMET 1"	RUBBER	1
6	GRUMET 3-4	GRUMET 3/4"	RUBBER	1
7	HANDLE ROD	MS HUB HANDLE ROD	MS	1
8	HOUSING	HOUSING IP-41 1/3 CM	SHEET METAL	1
9	TOP COVER	HOUSING TOP COVER IP-41 1/3 CM	SHEET METAL	1
10	LOCK WASHER	12X12 SQ 29X1.5MM	M.S.	1
11	ROLLER	10X5X10MM ROLLER	M.S.	1
12	PIN	5X20 MM ROLLER PIN	M.S.	1
13	HUB	12X45X25 MM MS HUB	M.S.	1
14	SPRING	NOTCHING SPRING	SPING STEEL	1
15	NOTCHING LEVER	80X15 MM	M.S.	1
16	KNOB	PLATIC KNOB	NYLON 6	1
17	RATCHET WHEEL	PLASTIC RATCHET WHEEL 18"	M.S.	1
18	PLASTIC STOPER	22X12X8MM	NYLON	1
19	SHAFT	12X12X180 SQ	M.S.	1
20	SPRING HOLDER	SPRING FITTING	M.S.	2
21	SQUARE BUSH	20X25X13MM , 12X12 MM SQ	NYLON 6	2
22	GASKET PATTI	BODY FIXING	RUBBER	1
23	END BUSH CLOSED	20X25X 35X70 X4MM	NYLON	1
24	E TYPE CIRCLIP	E CIRCLIP 11.5 MM, GEAR SHAFT	M.S.	1
25	CAM	SPARE CAM	NYLON	7
26	CONTACT STRIP	CONTACT BREAK STRIP	BRASS	7
27	CSK SCREW 5X10	CHEESED 5X10	M.S.	8
28	CHEESED SCREW	CHEESED SCREW M6X10	M.S.	7
29	SCREW CSK	END BUSH 5X10 CSK	M.S.	6
30	HEX NUT	M5	M.S.	6
31	PLAIN WASHER	11X5.5X1.5	M.S.	8
32	SPRING WASHER	WASHER A5	SPRING STEEL	8
33	PLAIN WASHER	13X6.5X1.5 PLAIN WASHER M6	M.S.	7
34	SPRING WASHER	WASHER A6	SPRING STEEL	7
35	GRUB SCREW	8X10 MM M8 THREAD	M.S.	1
36	LOCK	HOUSING LOCK	M.S.	2
37	NAME PLATE	71X33X0.5 (4 HOLES 2MM)	ALUMINIUM	1
38	ARROW STICKER	ARROW STICKER		1
39	TERMINAL STICKER	TERMINAL STICKER		1
40	ERTHING STICKER	ERTHING STICKER		1
41	STEP LONG STCIKER	STEP LONG STICKER		1
42	STICKER	DOWN ARROW STICKER		1
43	SHORT STICKER	SHORT STICKER		1
44	RIVET	RIVET FOE NAME PLATEB 4.5 MM	AB 4	1
45	E TYPE CIRCLIP	5MM CIRCLIP		1
46	BOLT	HEX BOLT 6X20	ALUMINIUM	1
47	CONTACT BLOCK	CONTACT BLOCK ASSEMBLY IP-41 40AMP		7

COMPANY NAME: **ANAND SYSTEM ENGINEERING PVT LTD**  
 Email id: info@anandcontrol.in  
 CONTACT NO: 9137620579  
 DO NOT SCALE DRAWING  
 TITLE: **MASTER CONTROLLER SMALL IP41-CM 1-3-IP41 2D**  
 DWG NO. A1  
 SCALE: 1:10  
 SHEET 1 OF 2



FRONT VIEW

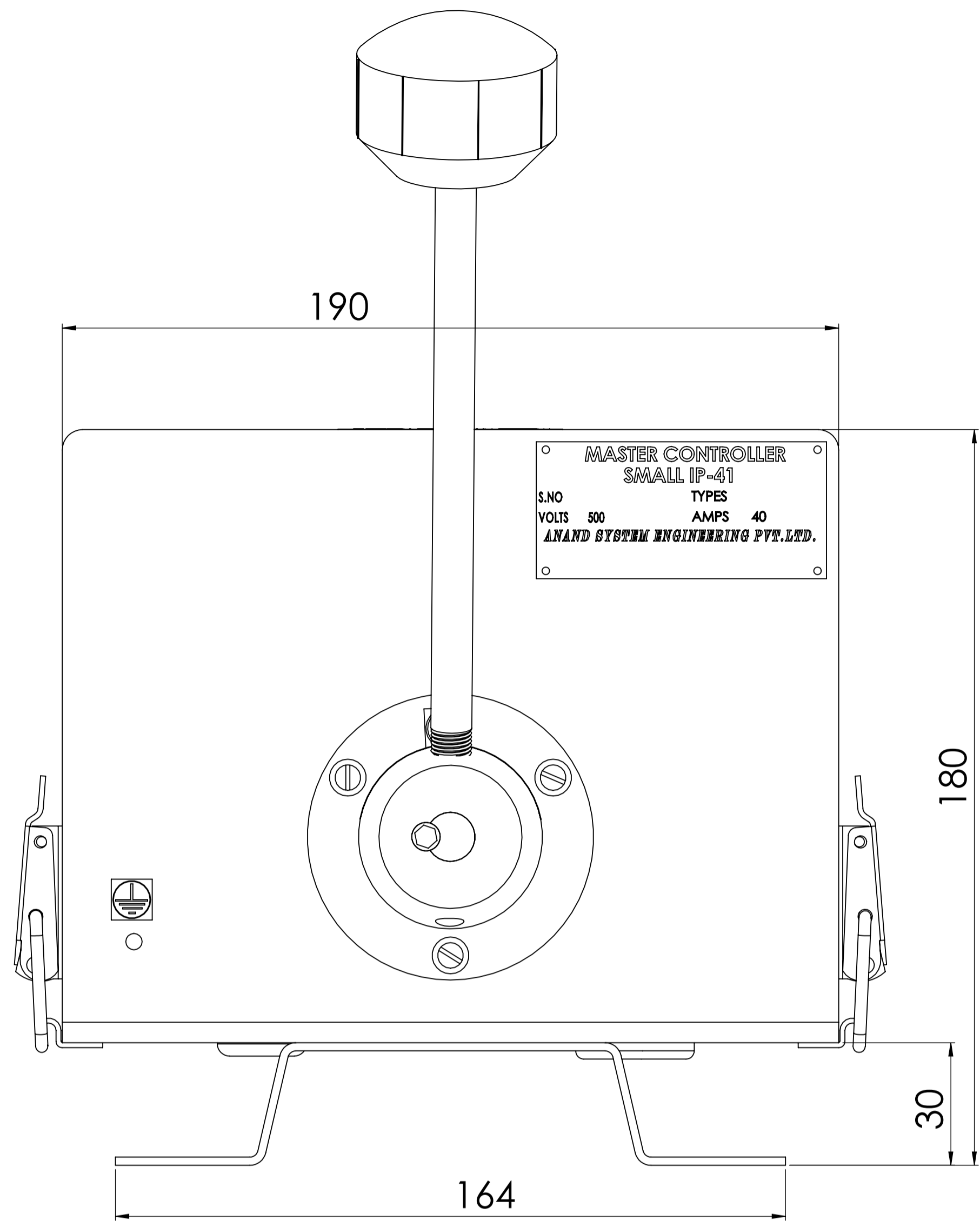

SIDE VIEW

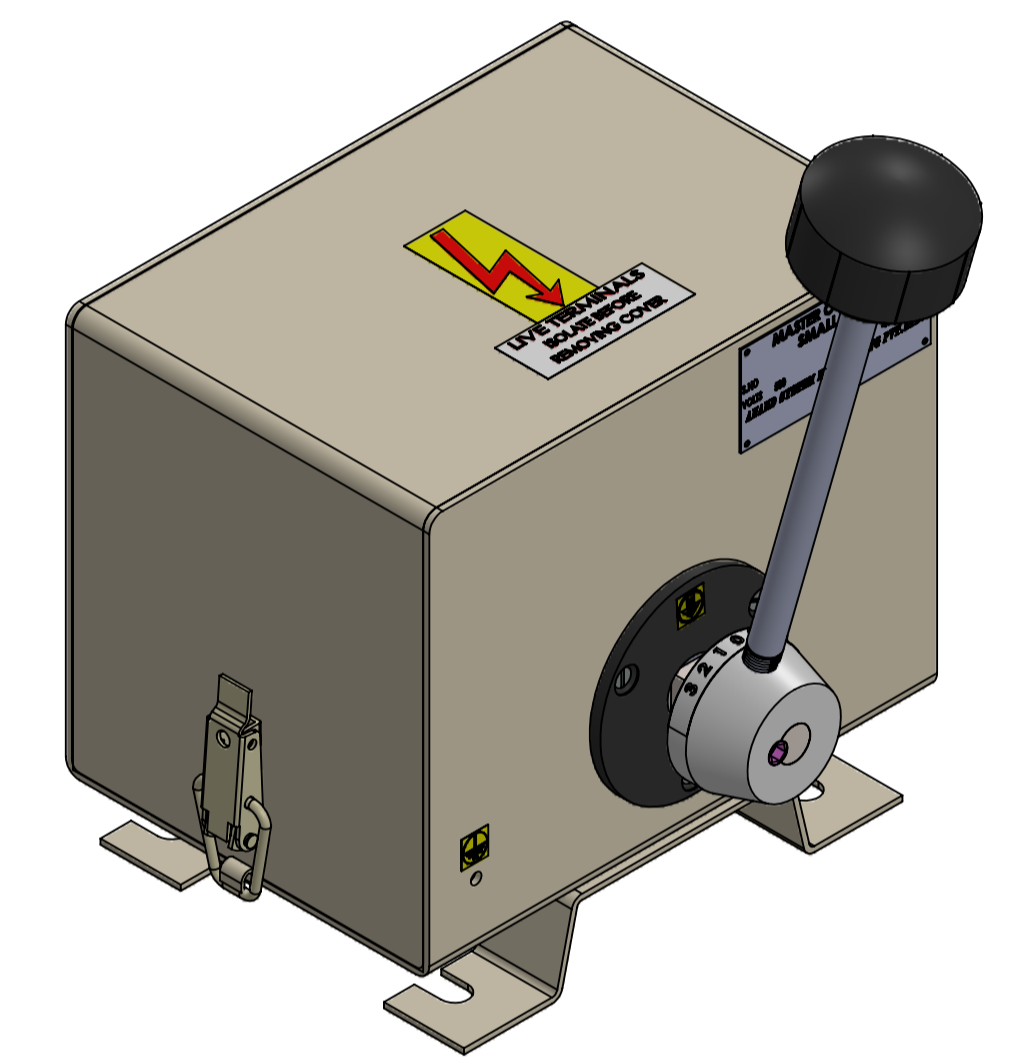
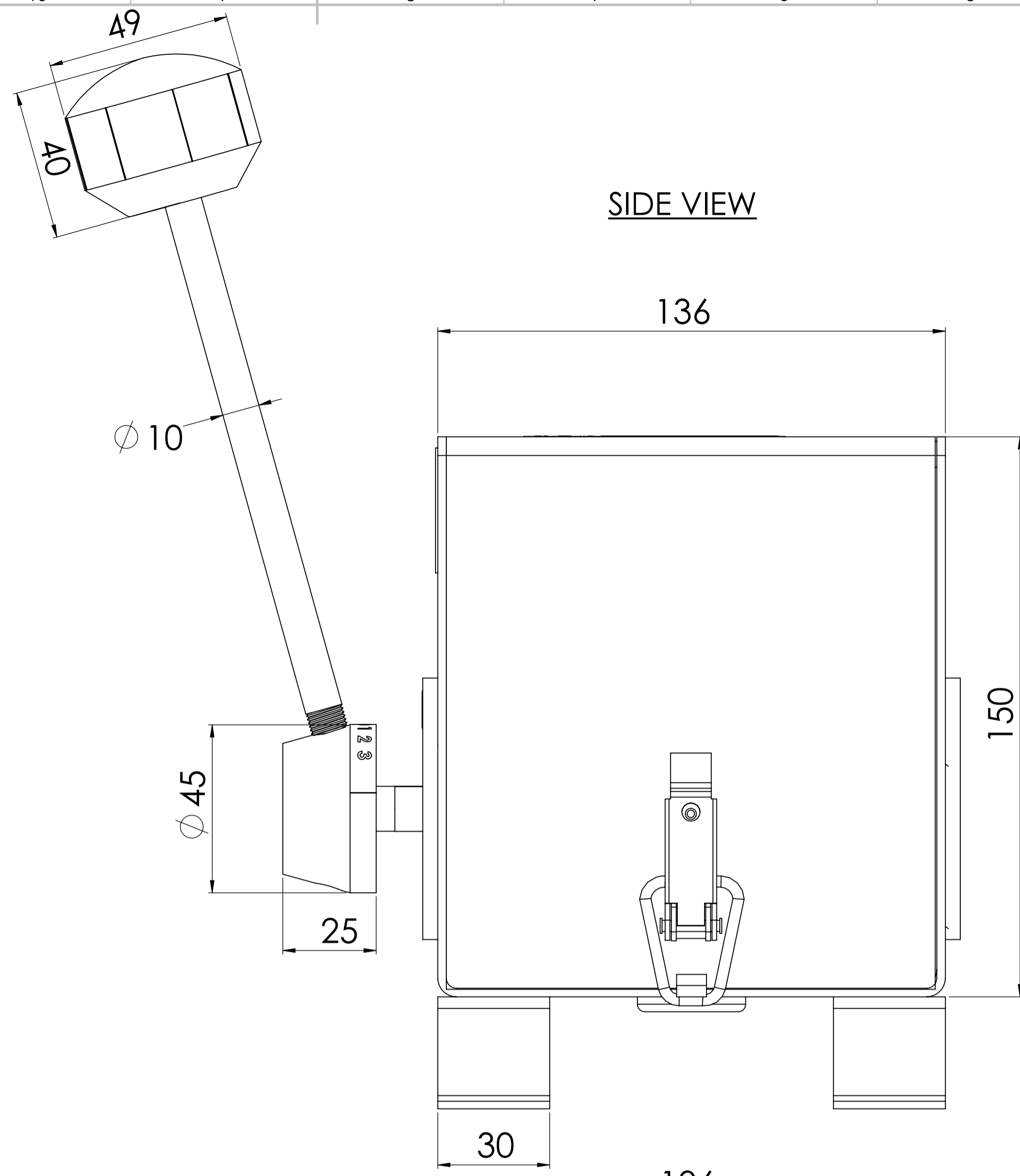

TOP VIEW

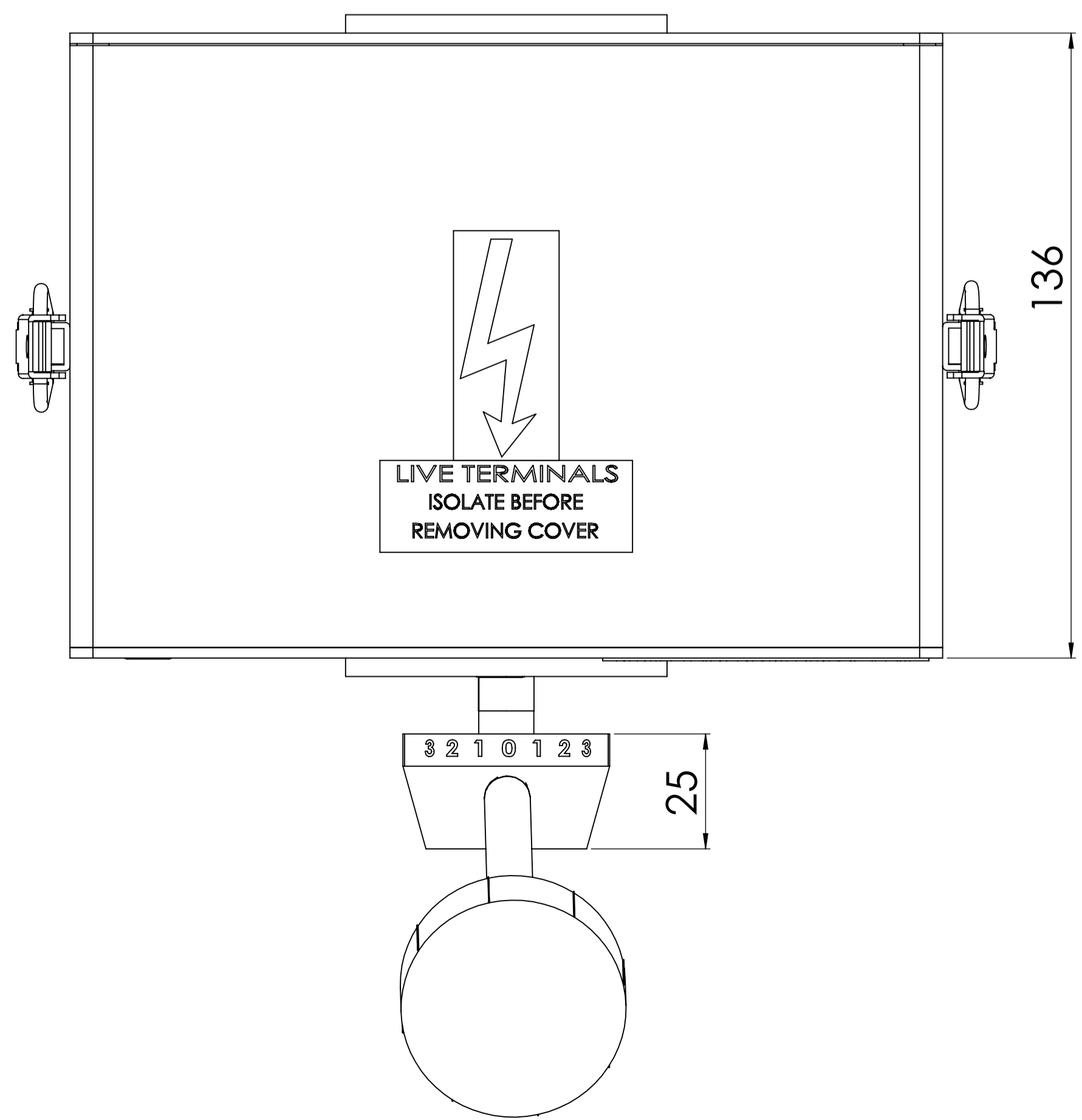

BOTTOM VIEW

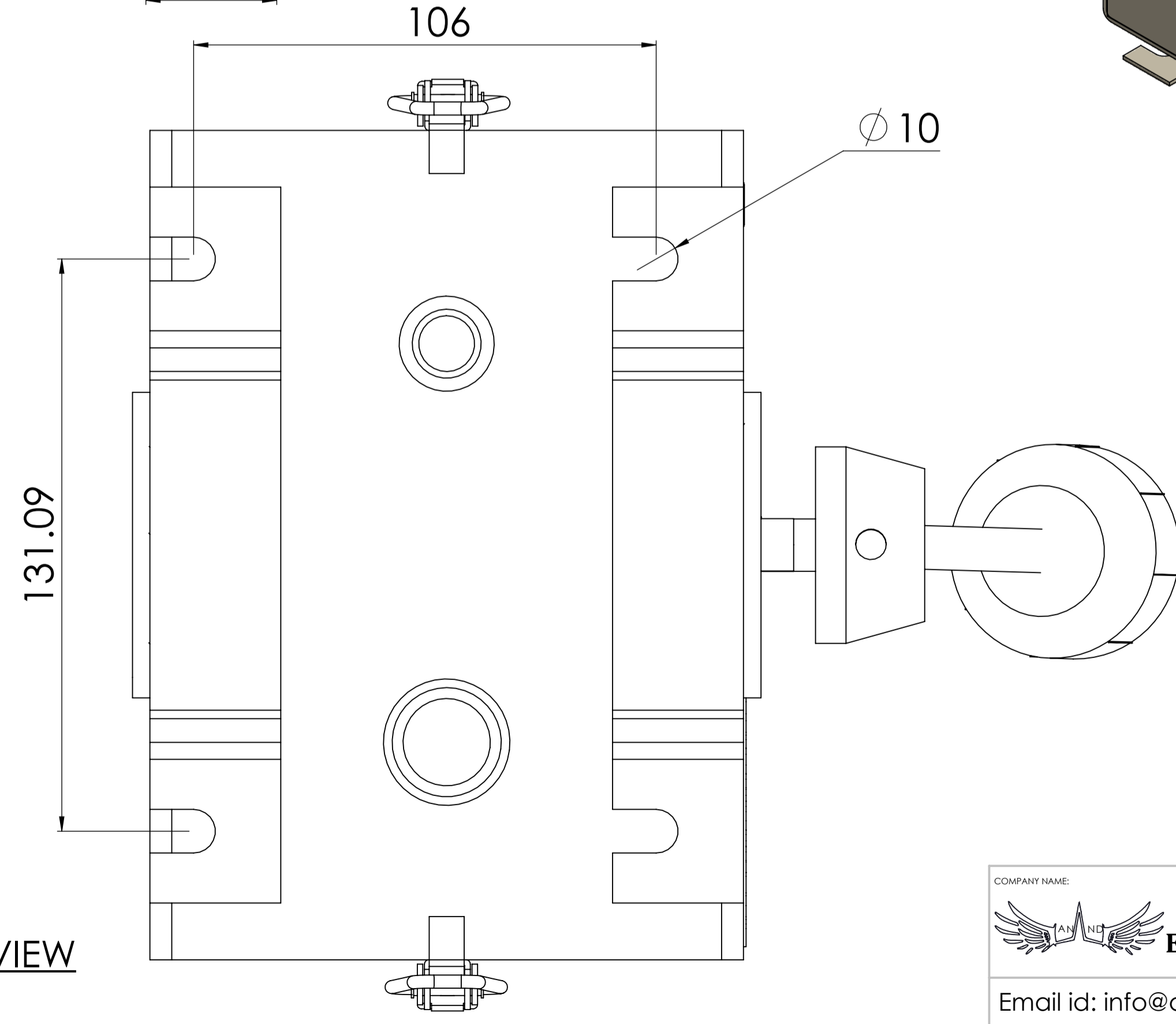

COMPANY NAME	<b>ANAND SYSTEM ENGINEERING PVT LTD</b>	DO NOT SCALE DRAWING	REVISION
Email id: info@anandcontrol.in		TITLE	<b>MASTER CONTROLLER SMALL IP-41 ASSEMBLY</b>
CONTACT NO: 9137620579		DWG NO.	A1
		SCALE:1:10	SHEET 2 OF 2