

EXPLODED VIEW

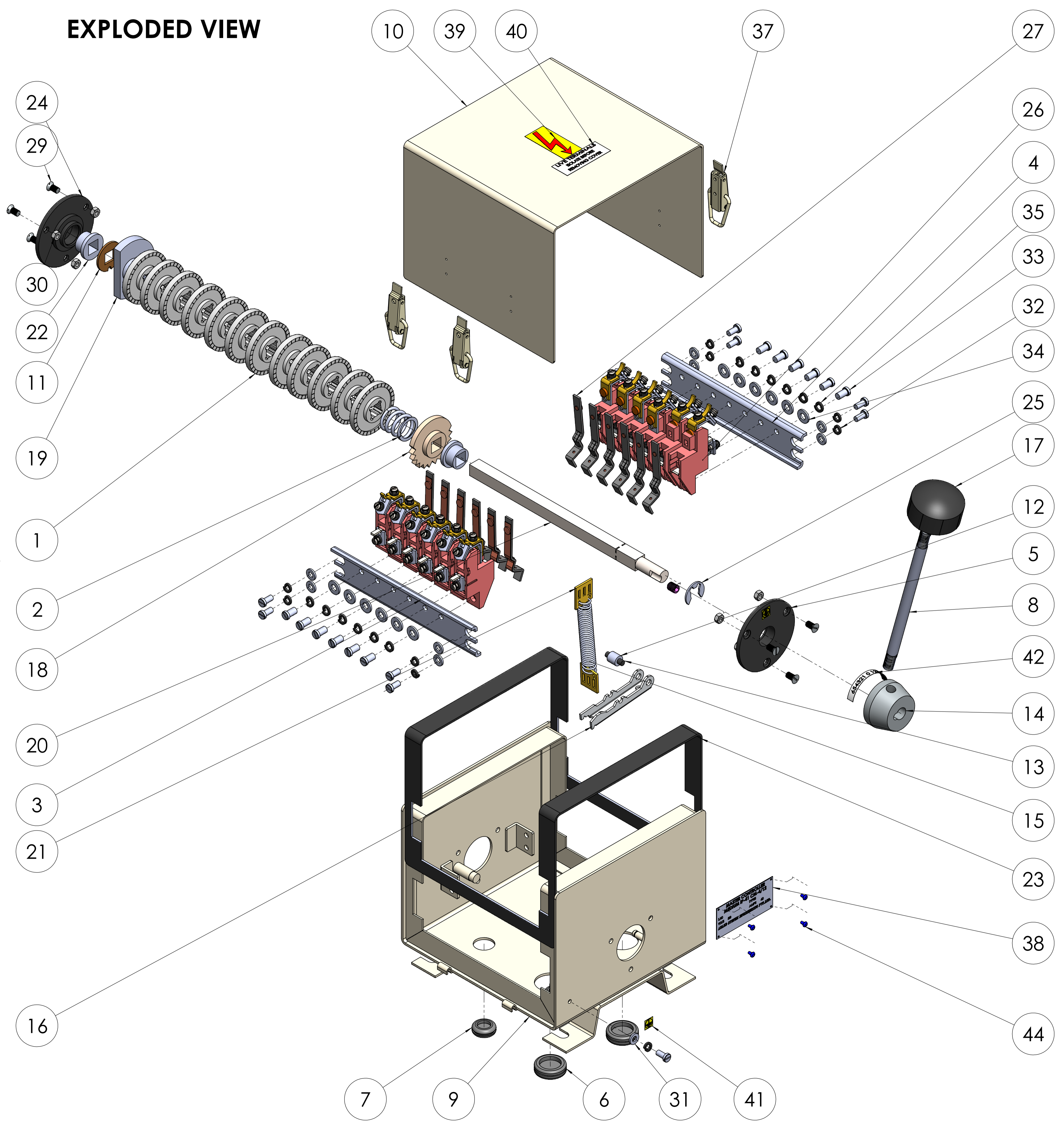

ITEM NO.	PART NAME	DESCRIPTION	Material	QTY.
1	CAM	CAM	NYLON	12
2	COMPRESSING SPRING	SHAFT & CAM FIXING	SPRING STEEL	1
3	CONTACT STRIP	LEFT SIDE CONTACT FIXING STRIP 6 HOLES	M.S.	1
4	CONTACT STRIP	RIDE SIDE CONTACT FIXING STRIP 7 HOLES	M.S.	1
5	END BUSH	END BUSH OPEN	NYLON	1
6	GRUMET	GRUMET 1"	RUBBER	2
7	GRUMET	GRUMET 3/4"	RUBBER	2
8	HANDLE ROD	MS HUB HANDLE ROD	MS	1
9	HOUSING	MEDIUM 190X190X180	SHEET METAL	1
10	TOP COVER	190X190	SHEET METAL	1
11	LOCK WASHER	12X12 SQ 29X1.5MM	M.S.	1
12	ROLLER	10X5X10MM ROLLER	M.S.	1
13	PIN	5X20 MM ROLLER PIN	M.S.	1
14	HUB	12X45X25 MM MS HUB	M.S.	1
15	SPRING	NOTCHING SPRING	SPING STEEL	1
16	NOTCHING LEVER	80X15 MM	M.S.	1
17	KNOB	PLATIC KNOB	NYLON 6	1
18	MS RATCHET WHEEL	RATCHET WHEEL 18"	M.S.	1
19	PLASTIC STOPER	22X12X8MM	NYLON	1
20	SHAFT	12X12X240 SQ	M.S.	1
21	SPRING HOLDER	SPRING FITTING	M.S.	2
22	SQUARE BUSH	20X25X13MM , 12X12 MM SQ	NYLON 6	2
23	GASKET PATTI	BODY FIXING	RUBBER	1
24	END BUSH CLOSED	20X25X 35X70 X4MM	NYLON	1
25	E TYPE CIRCLIP	E CIRCLIP 11.5 MM, GEAR SHAFT	M.S.	1
26	CONTACT BLOCK	CONTACT BLOCK ASSEMBLY IP-4140AMP	-	12
27	CONTACT STRIP	CONTACT BREAK STRIP	BRASS	12
28	CSK SCREW	CHEESED 5X10	M.S.	9
29	SCREW CSK	END BUSH 5X10 CSK	M.S.	6
30	HEX NUT	M5	M.S.	6
31	PLAIN WASHER	11X5.5X1.5	M.S.	9
32	SPRING WASHER	WASHER A5	SPRING STEEL	9
33	CHEESED SCREW	CHEESED SCREW M6X10	M.S.	12
34	PLAIN WASHER	13X6.5X1.5 PLAIN WASHER M6	M.S.	12
35	SPRING WASHER	WASHER A6	SPRING STEEL	12
36	GRUB SCREW	8X10 MM M8 THREAD	M.S.	1
37	LOCK	HOUSING LOCK	M.S.	4
38	NAME PLATE	71X33X0.5 (4 HOLES 2MM)	ALUMINIUM	1
39	ARROW STICKER	ARROW STICKER	-	1
40	TERMINAL STICKER	TERMINAL STICKER	-	1
41	ERTHING STICKER	ERTHING STICKER	-	1
42	STEP LONG STICKER	STEP LONG STICKER	-	1
43	STICKER	DOWN ARROW STICKER	-	1
44	RIVET AB4	NAME PLATE FIXING	ALUMINIUM	4

COMPANY NAME: **ANAND SYSTEM ENGINEERING PVT LTD**

TITLE: **MASTER CONTROLLER MEDIUM IP-41 4-12 ASSEMBLY 2D**

Email id: info@anandcontrol.in

CONTACT NO: [9137620579](tel:9137620579)

SCALE: 1:2

SHEET 1 OF 2

FRONT VIEW

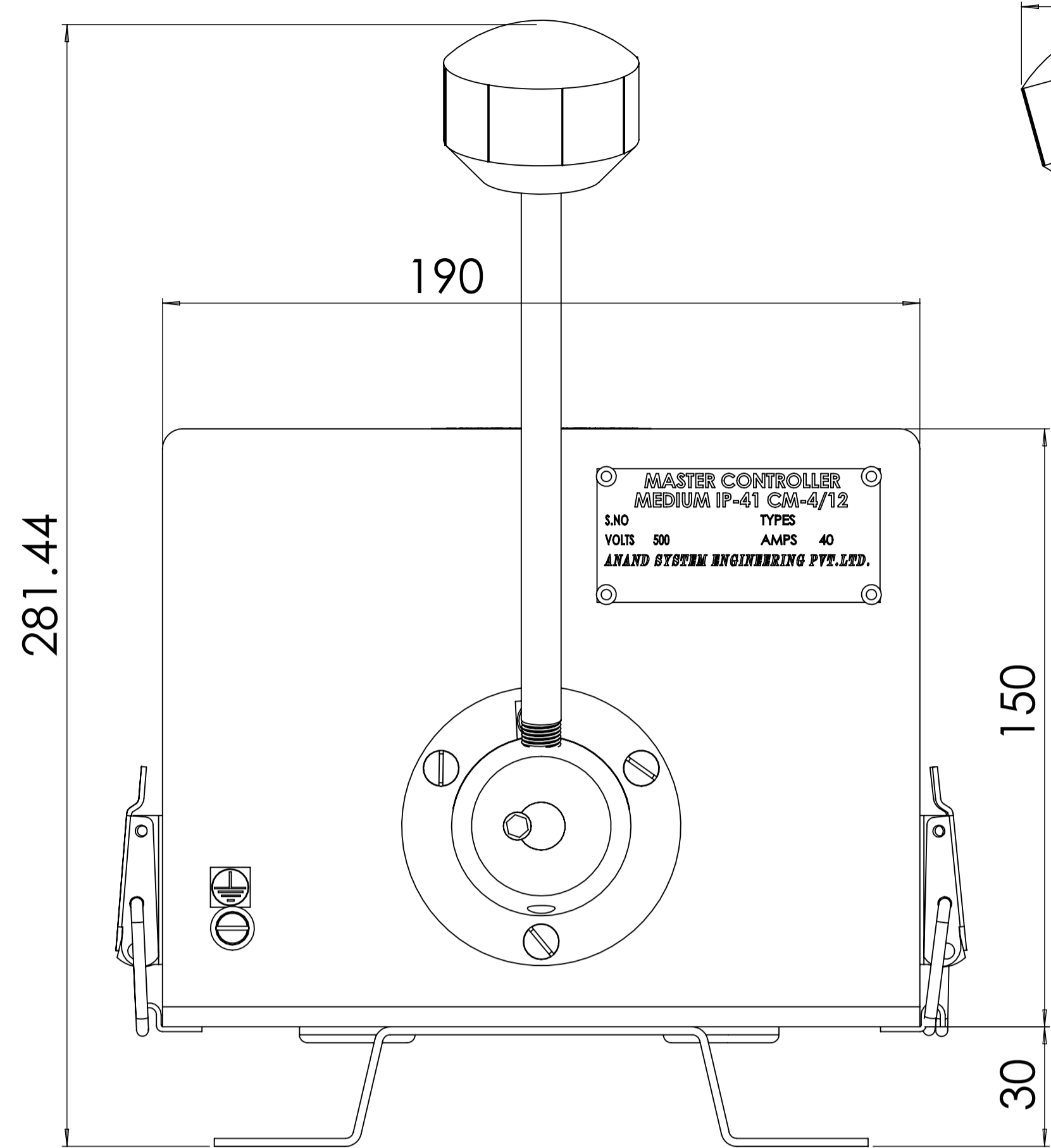

SIDE VIEW

299.88

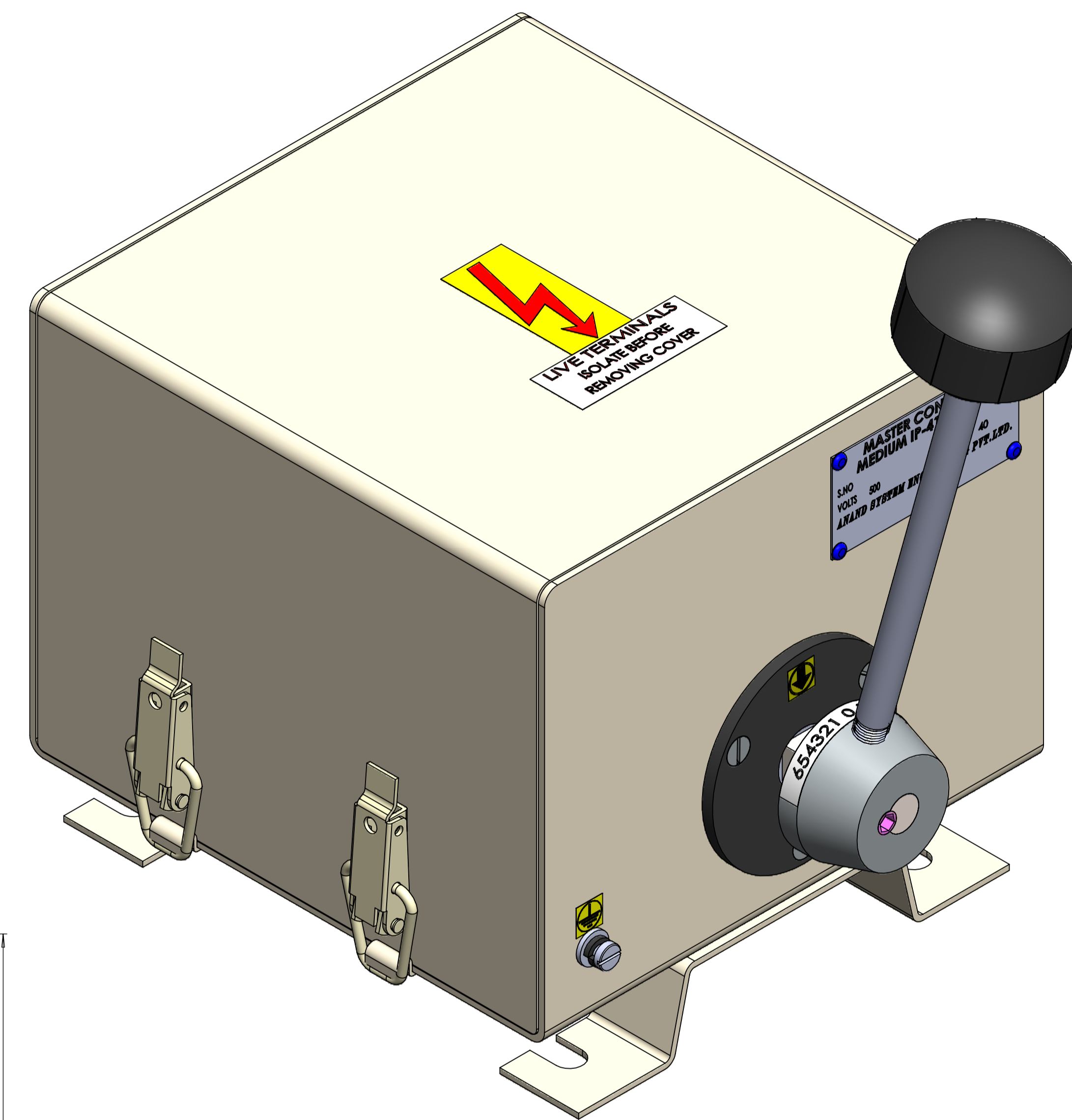
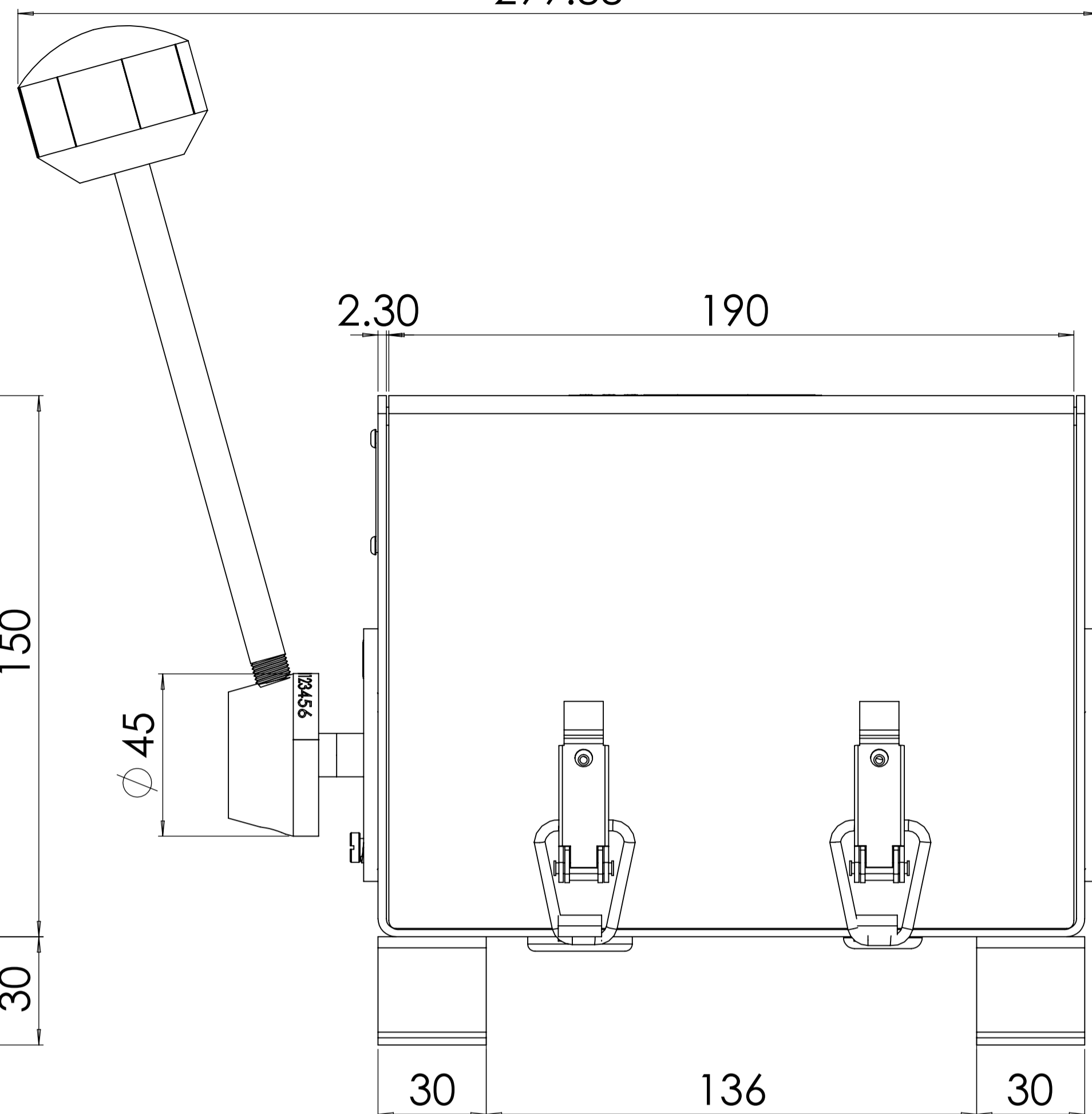

213.41

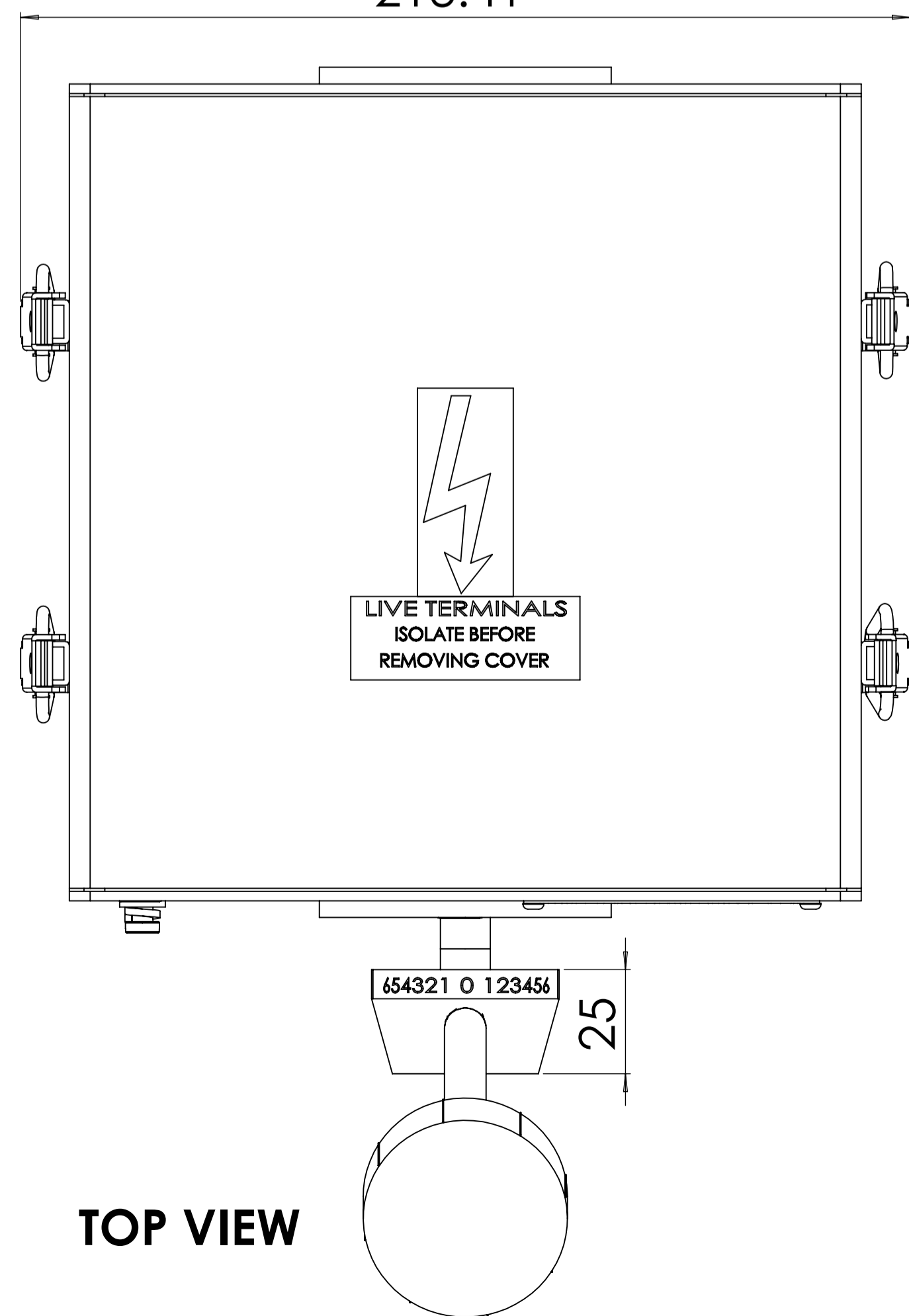

196

165.99

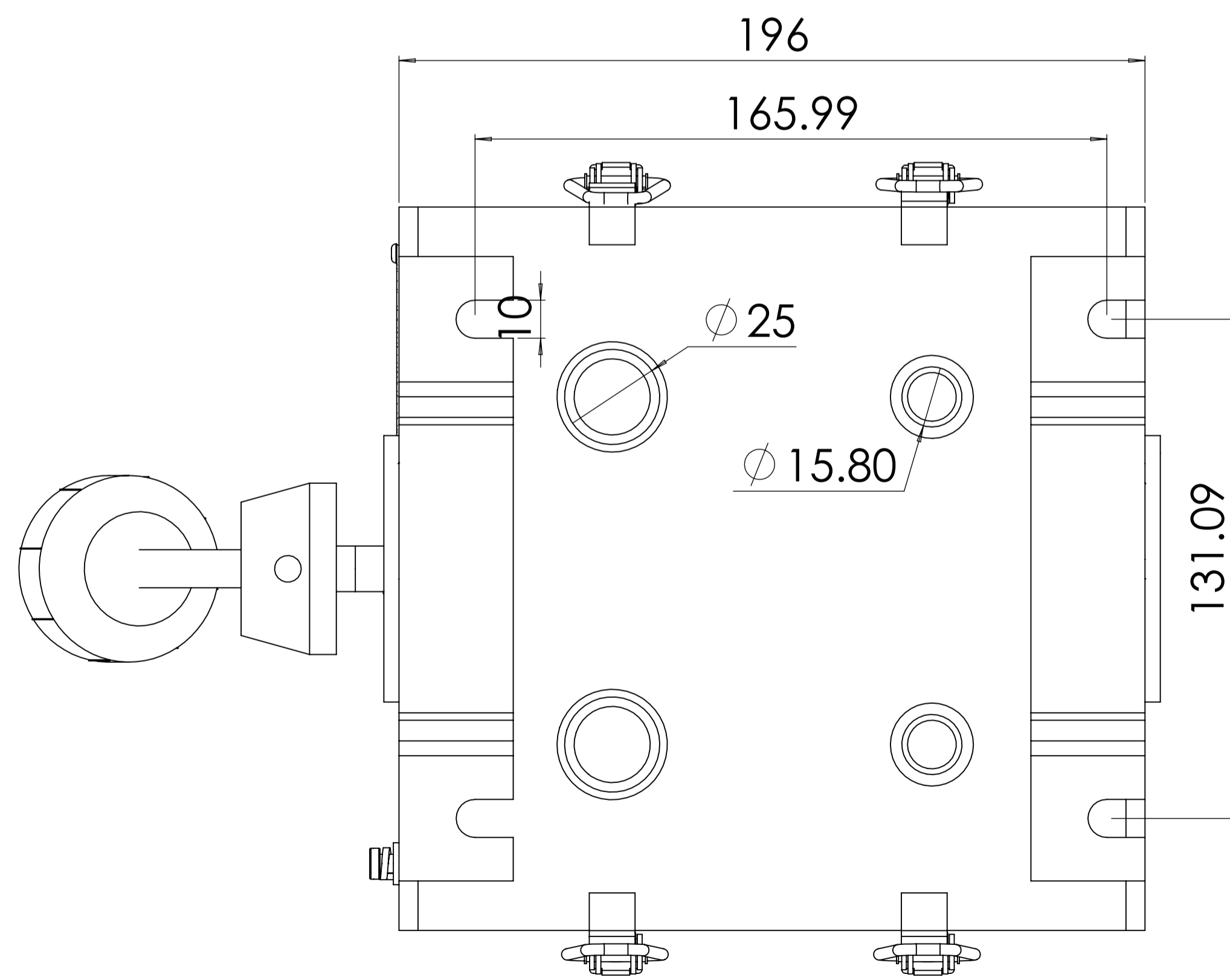

TOP VIEW

BOTTOM VIEW

COMPANY NAME:		ANAND SYSTEM ENGINEERING PVT LTD		DO NOT SCALE DRAWING	REVISION
		Email id: info@anandcontrol.in CONTACT NO: 9137620579		TITLE: MASTER CONTROLLER MEDIUM IP-41 4-12 ASSEMBLY 2D	
DRAWN:	SAURABH	DATE:	11-08-2024	MATERIAL:	
CHKD:					
APPVD:					
QA:					
				DATE:	SIGNATURE
				SCALE:1:2	SHEET 2 OF 2