

# EXPLODED VIEW

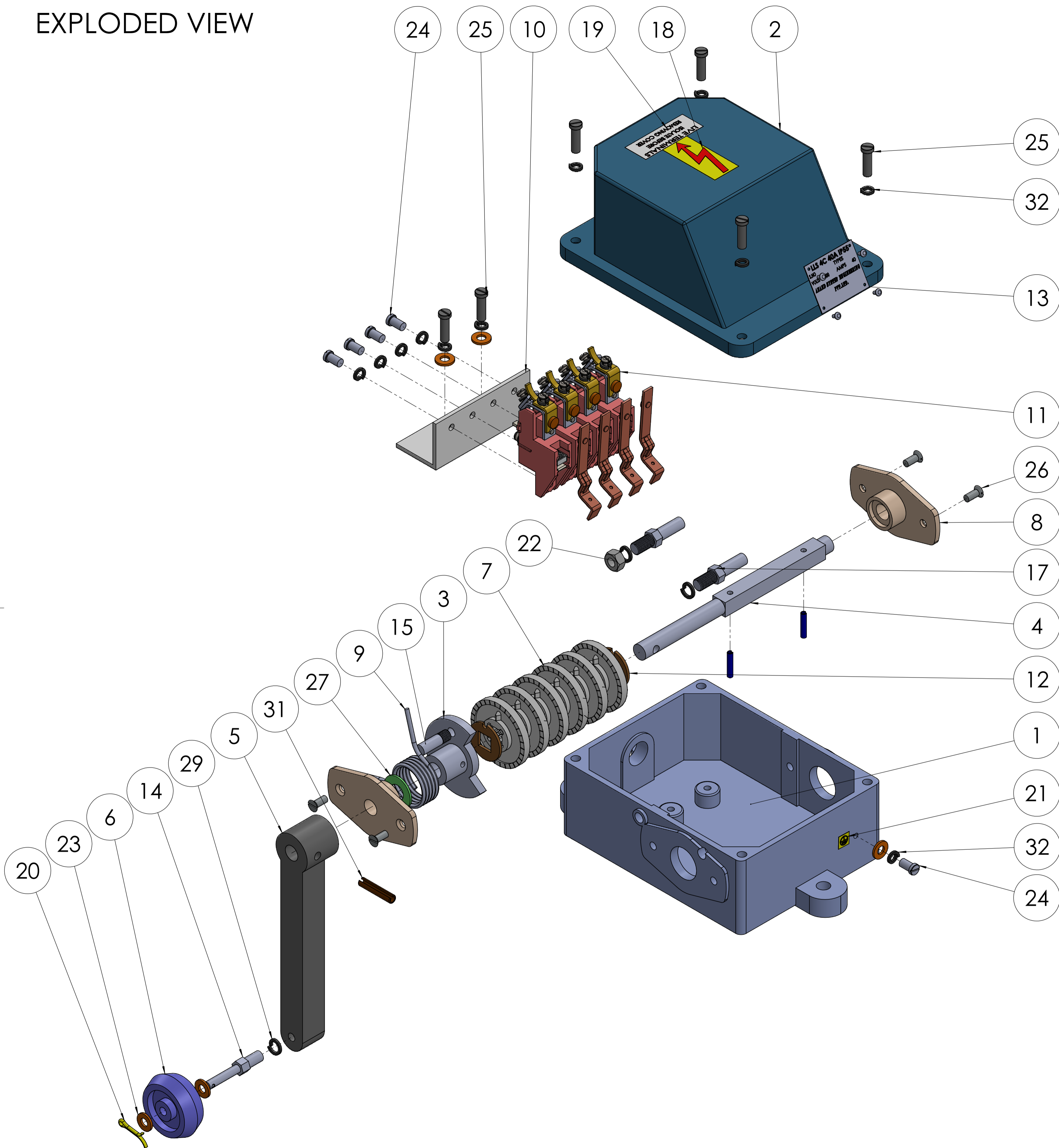

ITEM NO.	PART NAME	DESCRIPTION	Material	QTY.
1	BOTTOM COVER	172X135X61	ALUMINIUM DIE CAST	1
2	TOP COVER	180X143X78	ALUMINIUM DIE CAST	1
3	STOPER	22X12X8MM	M.S.	1
4	SHAFT	SQ SHAFT 12X180X MIDDLE 95MM	M.S.	1
5	HANDLE	C.I. HANDLE	C.I.	1
6	HANDLE ROLLER	20X Ø 47	NYLON	1
7	CAM	CAM	NYLON	6
8	END BUSH	Ø 12MM	NYLON	2
9	REVERSE SPRING	REVERSE SPRING 3MM	SPRING STEEL	1
10	CONTACT STRIP	90MM LONG THK-3MM	ALUMINIUM	1
11	CONTACT BLOCK	CONTACT BLOCK ASSEMBLY	-	4
12	LOCK WASHER	LOCK WASHER 12X12 SQ 29X1.5MM	M.S.	2
13	NAME PLATE	45X35X0.5(4 HOLES 2MM)	ALUMINIUM	1
14	HANDLE ROLLER PIN	6X9X50, M8 THREAD	M.S.	1
15	SPLIT PIN	8X26 , M8 THREAD	M.S.	1
17	STOPPER PIN	HEX ROD 11X50, M8 THREAD	M.S.	2
18	ARROW STICKER	ARROW STICKER	PVC	1
19	TERMINAL STICKER	TERMINAL STICKER	PVC	1
20	COTTER PIN 1-16"X 3-4"	1/16"X 3/4"	M.S.	1
21	ERTHING STICKER	ERTHING LEVEL	PVC	1
22	HEX NUT	M8	M.S.	1
23	PLAIN WASHER M6	13X6.5X1.5	M.S.	5
24	CHEESED SCREW	CHEESED SCREW M6X10	M.S.	5
25	SCREW	6X20	M.S.	6
26	SCREW CSK	END BUSH 5X10 (CSK)	M.S.	4
27	PLAIN WASHER	25X13.5X1.5	M.S.	1
28	RIVET AB4	NAME PLATE FIXING	ALUMINIUM	4
29	SPRING WASHER M8	M8	SPRING STEEL	3
30	TUBLER PIN	4X20 SHAFT FIXING TUBLER PIN	SPRING STEEL	2
31	TUBLER PIN	6X30 HANDLE FIXING TUBLER PIN	SPRING STEEL	1
32	SPRING WASHER	M6	SPRING STEEL	11

COMPANY NAME: **ANAND SYSTEM ENGINEERING PVT LTD**

EMAIL ID: info@anandcontrol.in

CONTACT NO: 9137620579

TITLE: **LEVER LIMIT SWITCH 4C 40 AMP IP55 ASSEMBLY 2D**

SCALE: 1:15

SHEET 1 OF 2

DO NOT SCALE DRAWING

REVISION

DWG NO.

DATE

SIGNATURE

A1

FRONT VIEW

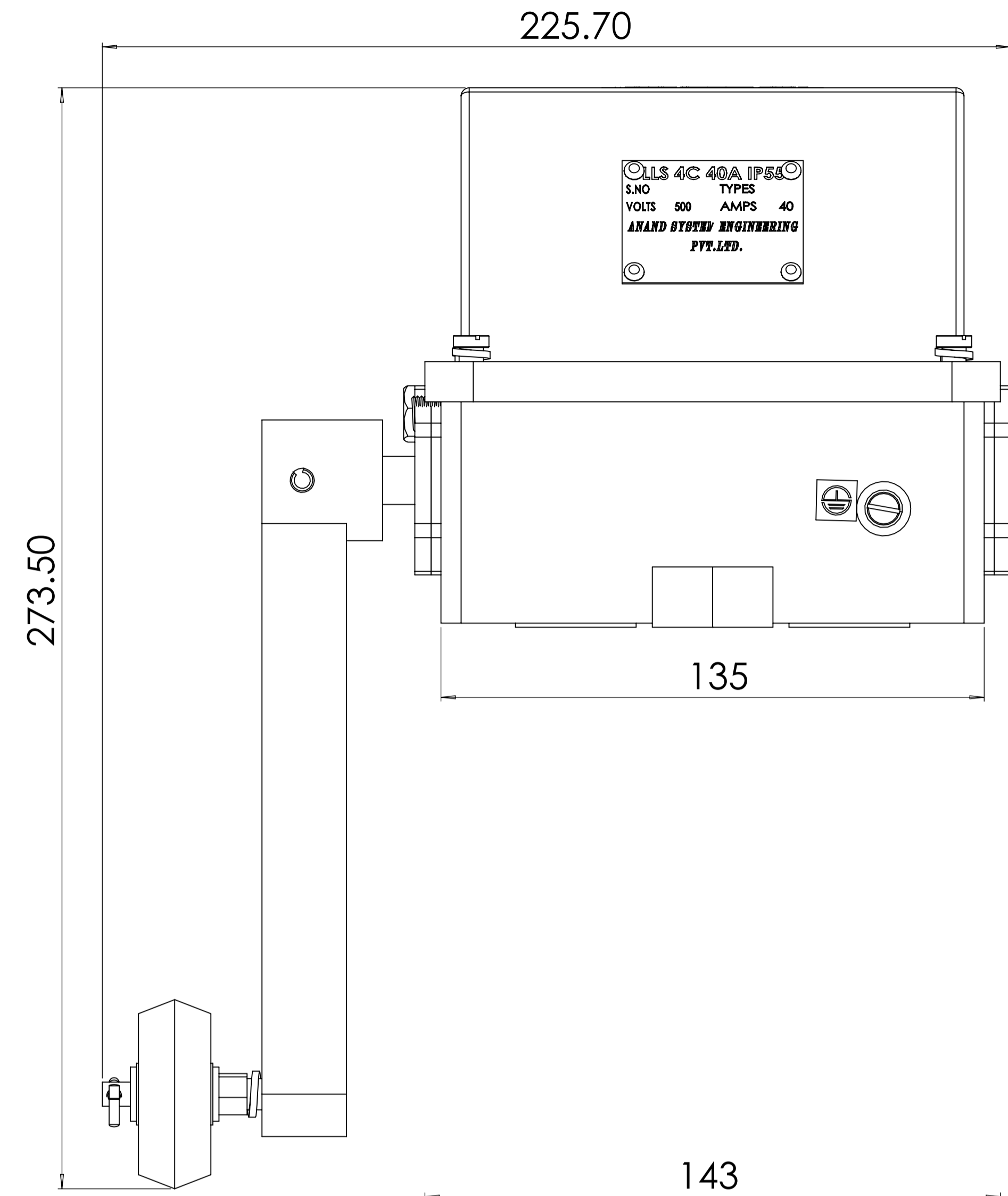

SIDE VIEW

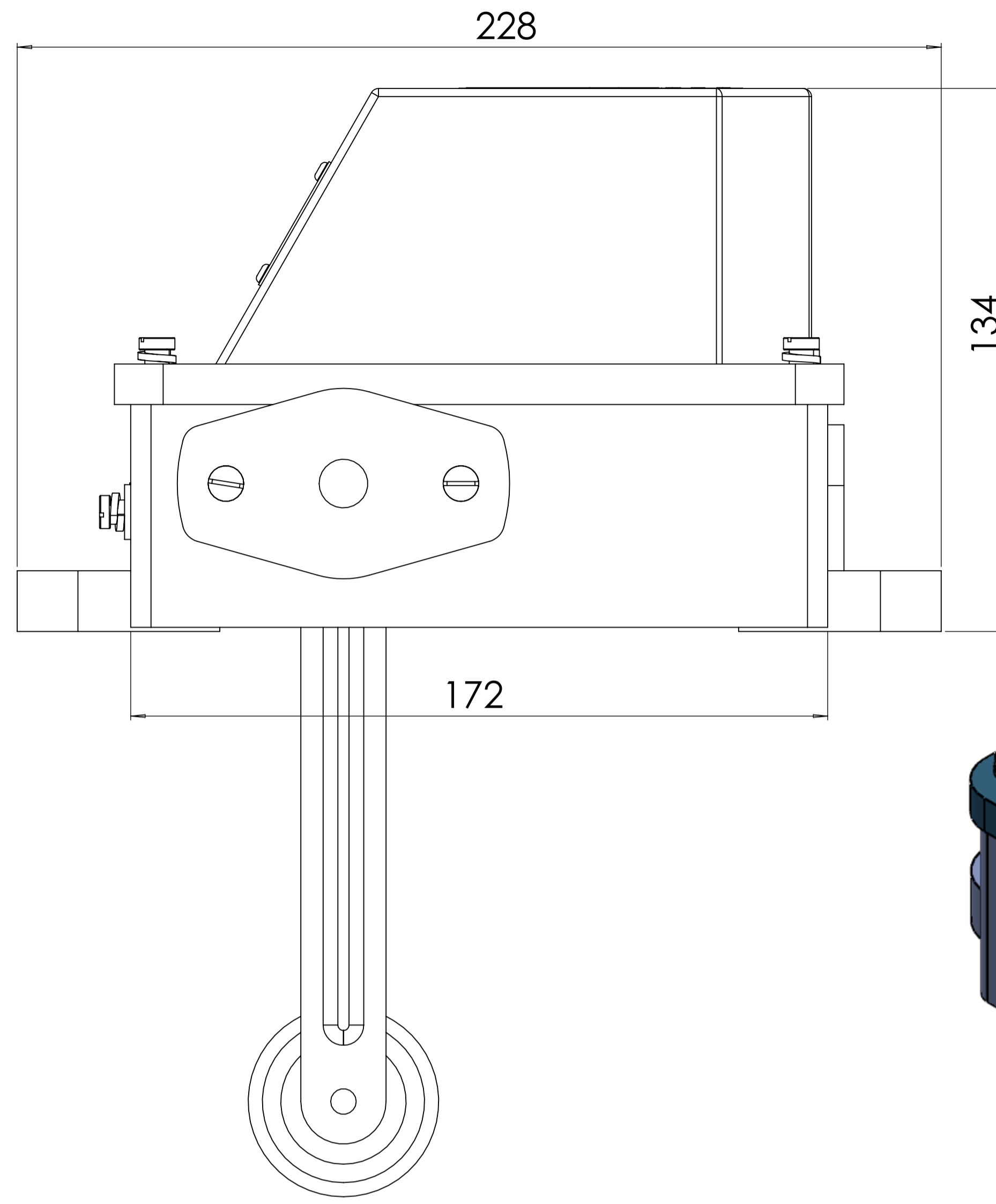

TOP VIEW

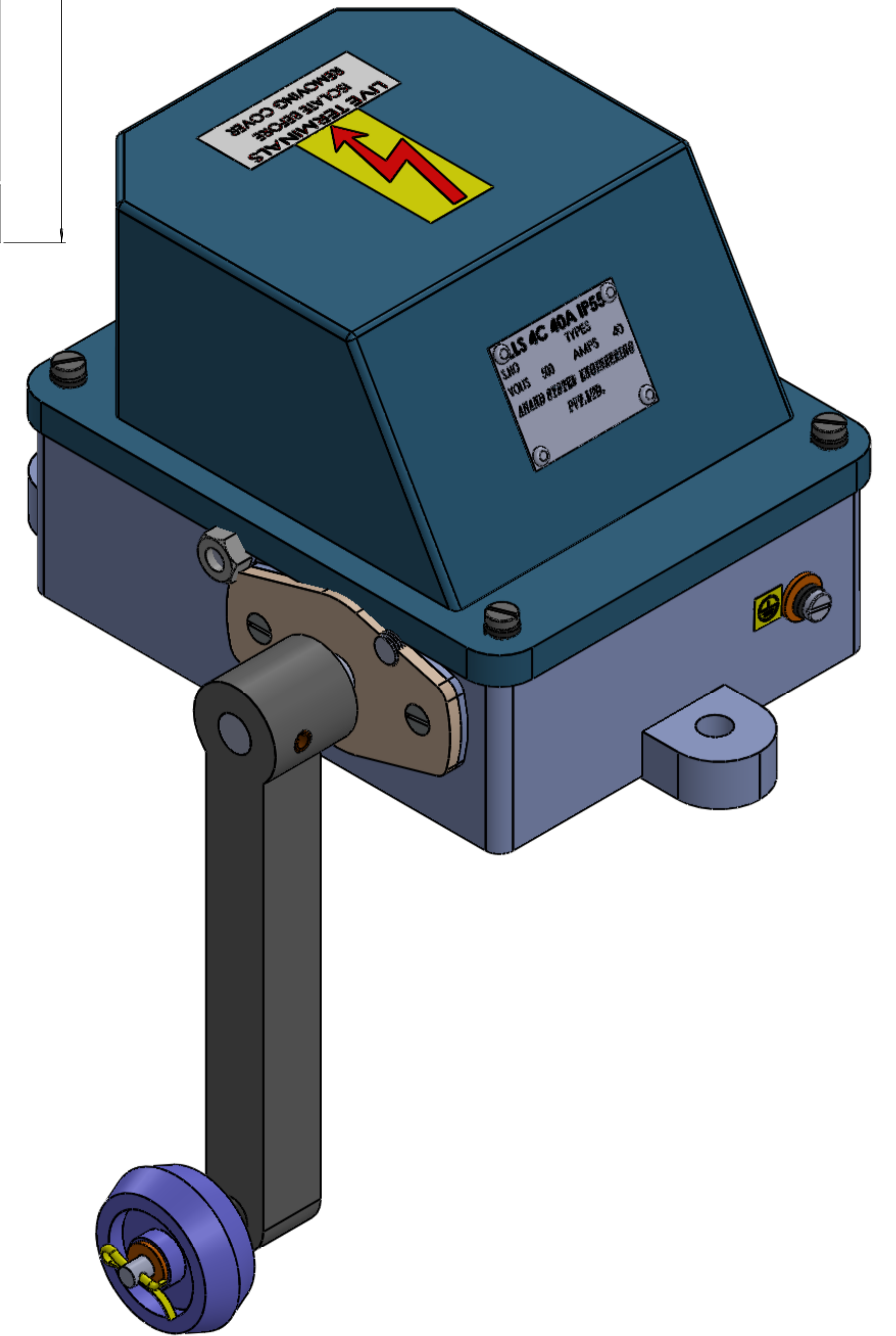
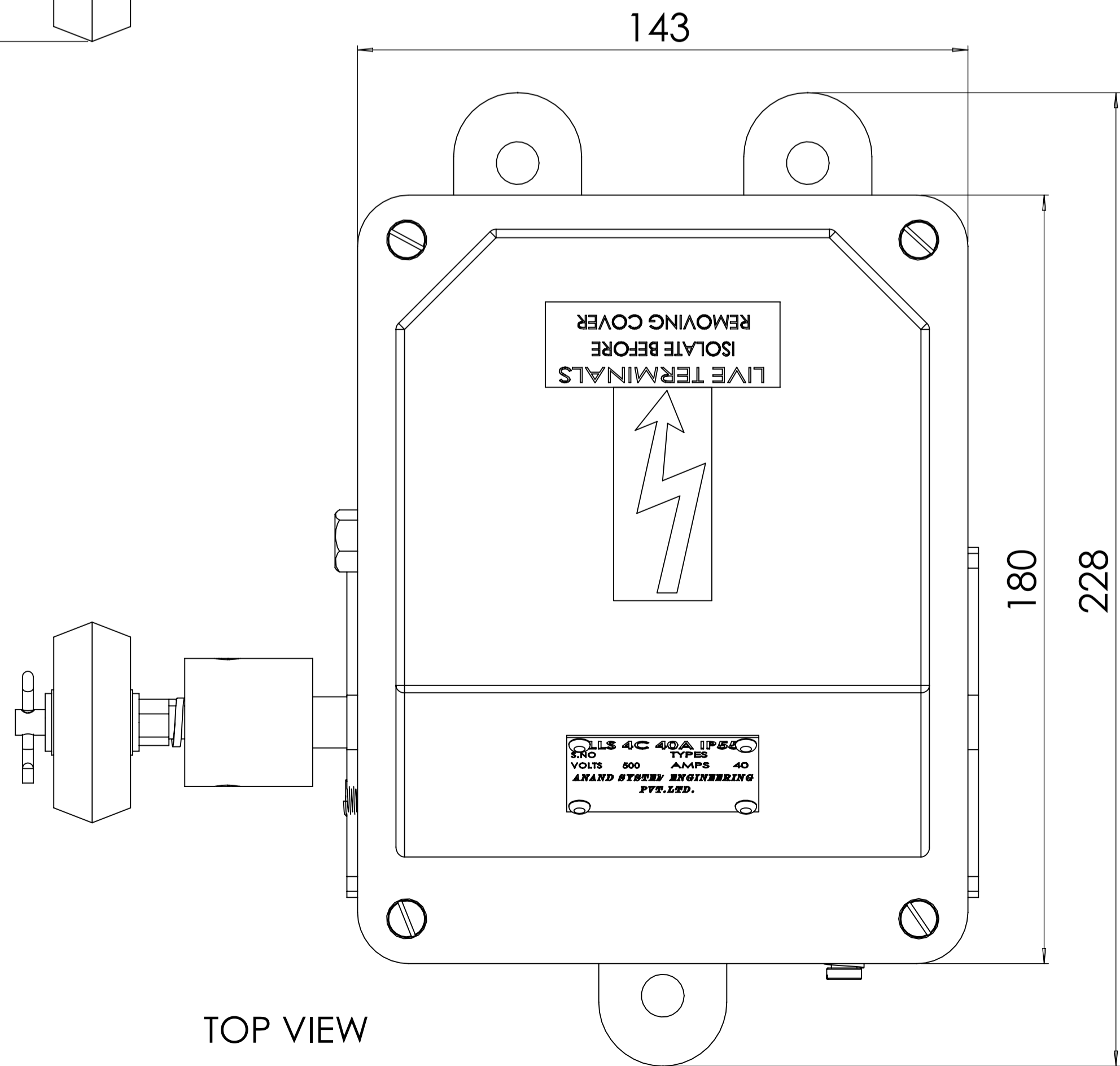

COMPANY NAME  
 **ANAND SYSTEM ENGINEERING PVT LTD**

Email id: info@anandcontrol.in

CONTACT NO: 9137620579

DO NOT SCALE DRAWING REVISION  
 TITLE: **LEVER LIMIT SWITCH 4C 40 AMP IP55 ASSEMBLY 2D**

DATE: 30-08-2024  
 DRAWN: SAURABH  
 CHECKED: \_\_\_\_\_  
 APPVED: \_\_\_\_\_  
 MFG: \_\_\_\_\_

DWG NO: \_\_\_\_\_  
 SIGNATURE: \_\_\_\_\_  
 SCALE: 1:15  
 SHEET 2 OF 2