

# EXPLODED VIEW

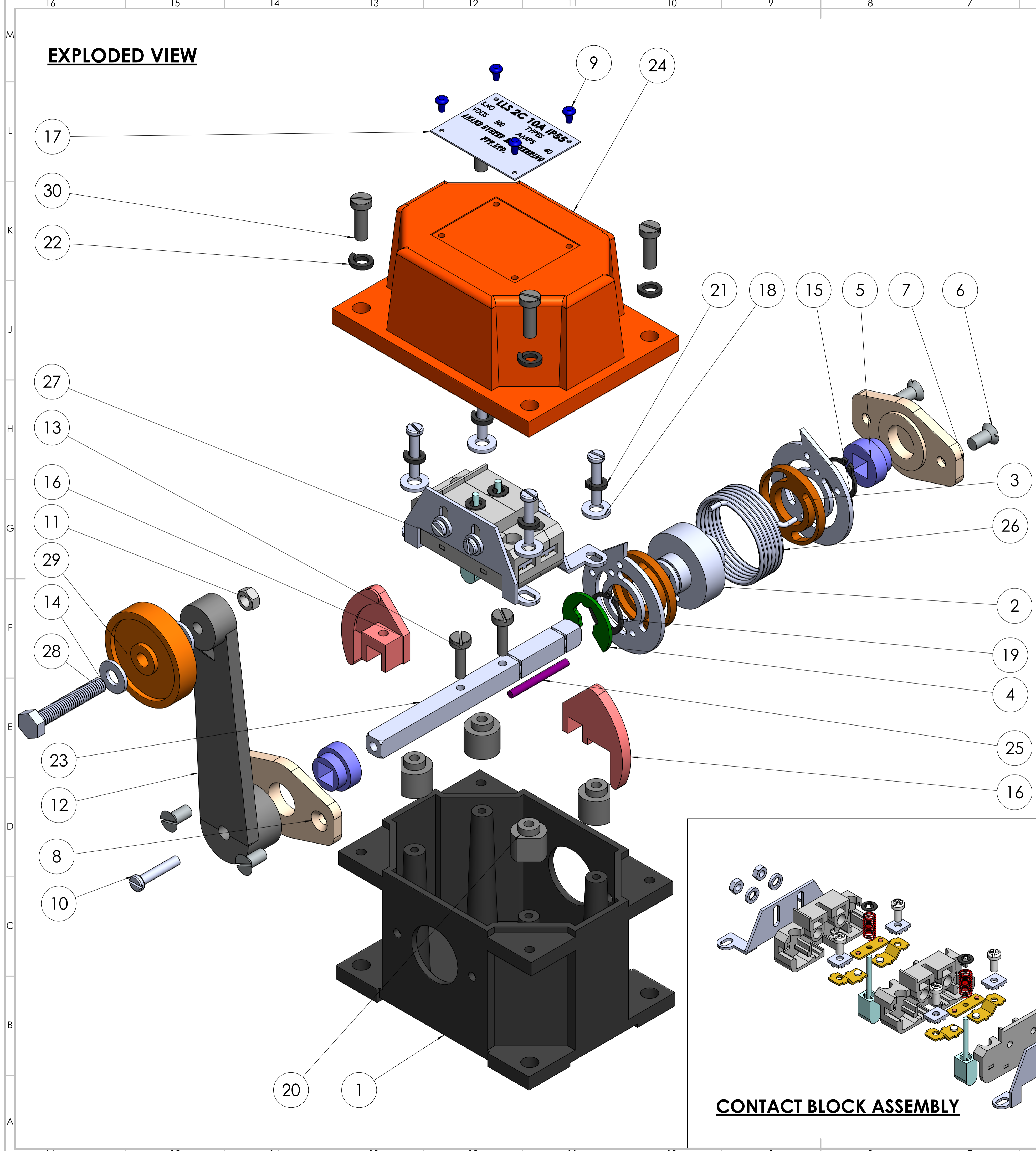

ITEM NO.	PART NAME	DESCRIPTION	MATERIAL	QTY.
1	BOTTOM COVER	106X75X63	ALUMINIUM	1
2	DAMRU MIDDLE	32X24	PLASTIC DERLINE	1
3	DAMRU SIDE	32X24	PLASTIC DERLINE	2
4	E CIRCLIP 8mm	8X25	M.S.	1
5	END BUSH	10X17.5X 8 SQ	NYLON 6	2
6	SCREW CSK	END BUSH 5X10 (CSK)	M.S.	4
7	END BUSH PLATE CLOSE	55X32X4.3THK	NYLON 6	1
8	END BUSH PLATE OPEN	55X32X4.3THK	NYLON 6	1
9	RIVET AB4	4.5MM	ALUMINIUM	4
10	M4 SCREW	4X20 HANDLE FIXING	M.S.	5
11	HEX NUT	M6	M.S.	1
12	LEVER HANDLE ROLLER	40X6.5	NYLON 6	1
13	HEX BOLT	5X15 SLOTTED	M.S.	2
14	PLAIN WASHER M6	13X6.5X1.5	M.S.	2
15	MAJAK	Ø 42MM	M.S. DIE CAST	2
16	MOLDED CAM	Ø 31.5X26	NYLON 6	2
17	NAME PLATE	45X35X0.5(4 HOLES 2MM)	ALUMINIUM	1
18	PLAIN WASHER	11X5.5X1.5	M.S.	4
19	RING TYPE CIRCLIP	12MM	M.S.	2
20	SPACER	GFN MOLDED, 4MM	PLASTIC	4
21	SPRING WASHER	WASHER M5	SPRING STEEL	4
22	SPRING WASHER	WASHER M6	SPRING STEEL	4
23	SQUARE SHAFT	8X104, M5 TAP	M.S.	1
24	TOP COVER	105X80X45	ALUMINIUM DIE CAST	1
25	TORSION PIN	30X3	M.S.	1
26	TORSION SPRING	COIL2.6, 35X42, 6 TURNS	SPRING STEEL	1
27	CONTACT BLOCK ASSEMBLY 1	-	-	1
28	HEX BOLT	5X35, HANDLE FIXING	M.S.	1
29	LEVER HANDLE ROLLER	125X26X18	ALUMINIUM SAND CAST	1

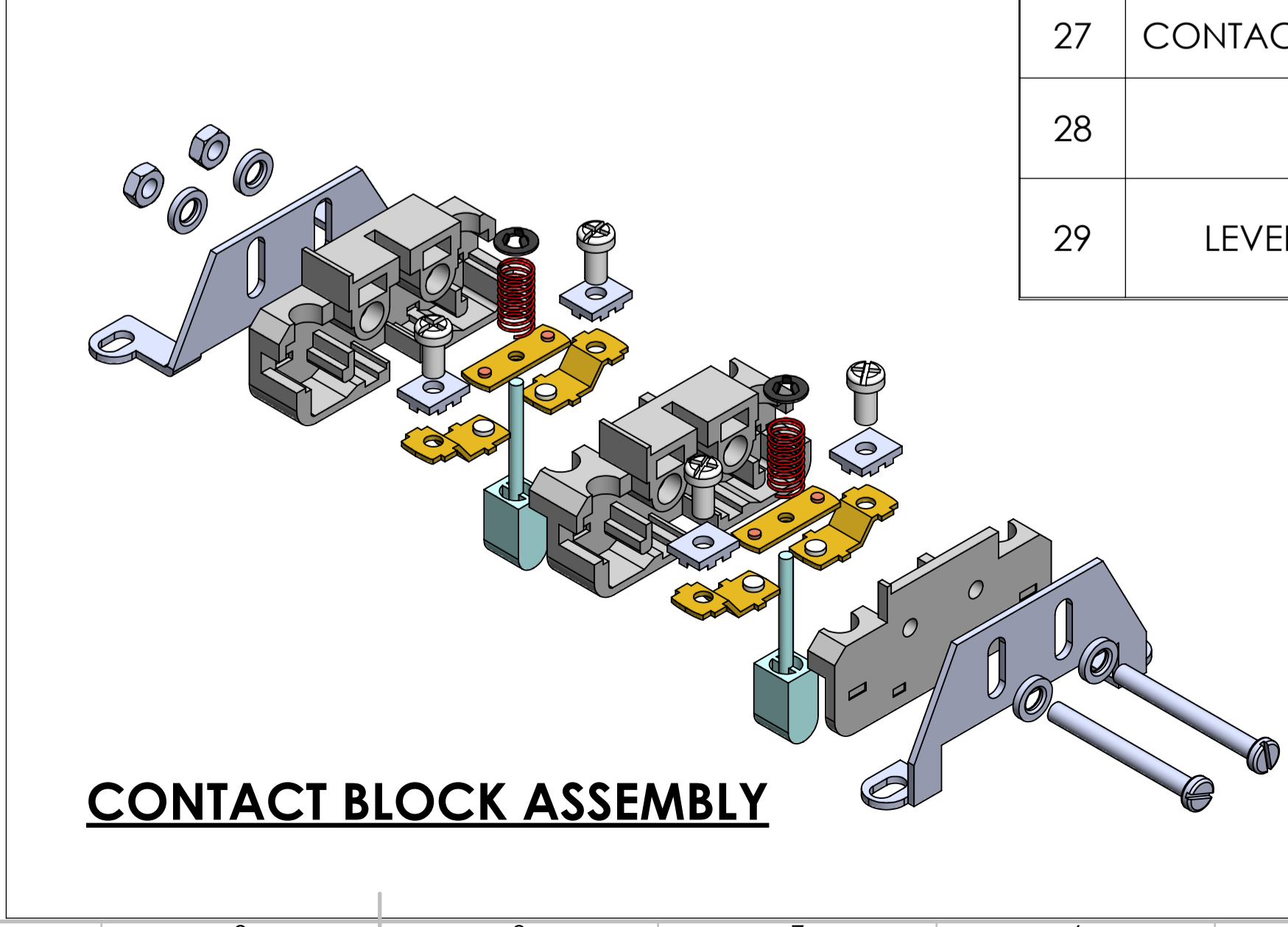

COMPANY NAME: **ANAND SYSTEM ENGINEERING PVT LTD**

DO NOT SCALE DRAWING

TITLE: **LEVER LIMIT SWITCH 2C 10A IP-55 2D**

REVISION

EMAIL ID: [info@anandcontrol.in](mailto:info@anandcontrol.in)

CONTACT NO: [9137620579](tel:9137620579)

DWG NO.

DATE

SIGNATURE

SCALE: 1:1

SHEET 1 OF 2

DRAWN

CHK'D

APP'VD

G.A.

MATERIAL:

WEIGHT:

A1



FRONT VIEW

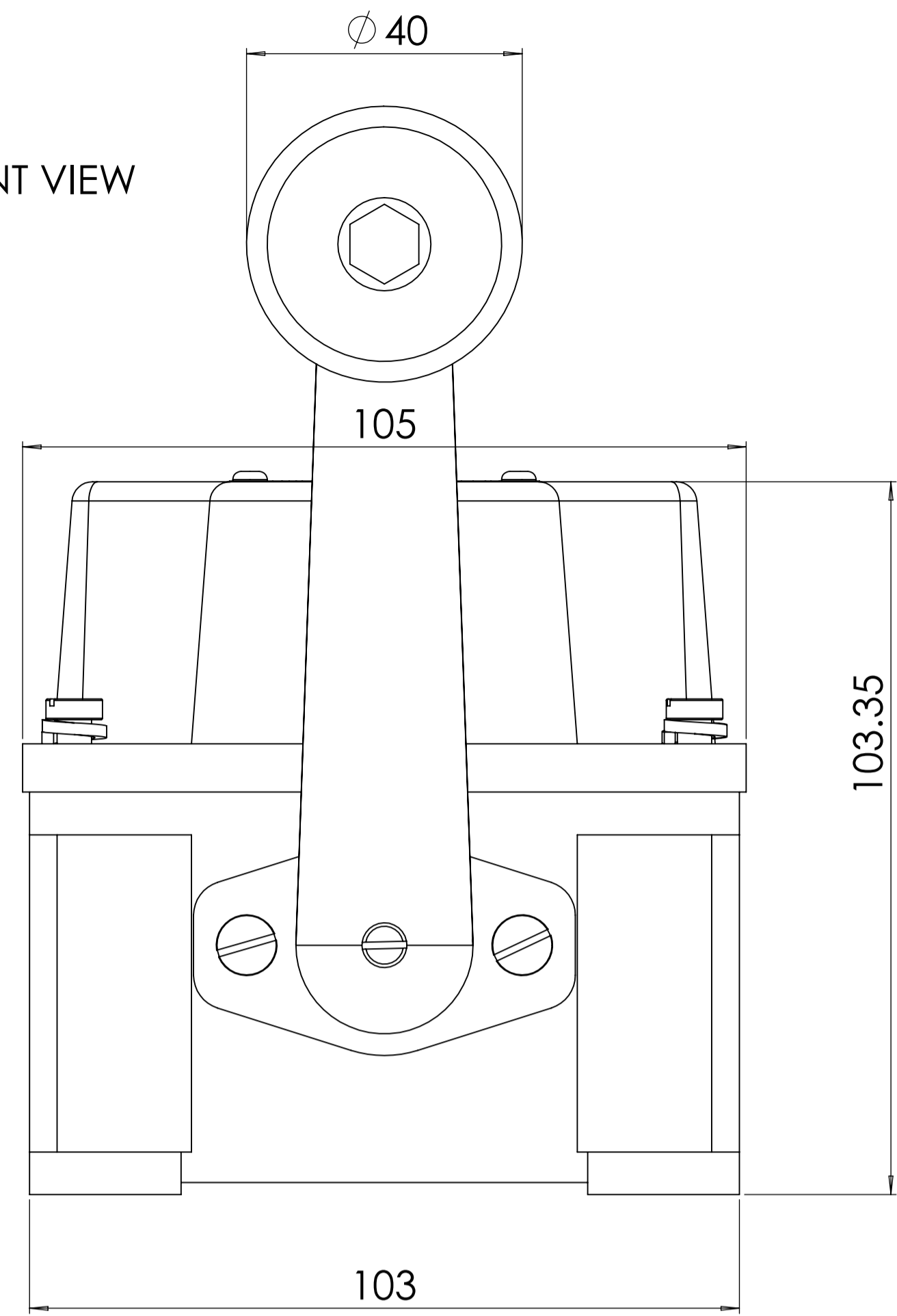

SIDE VIEW

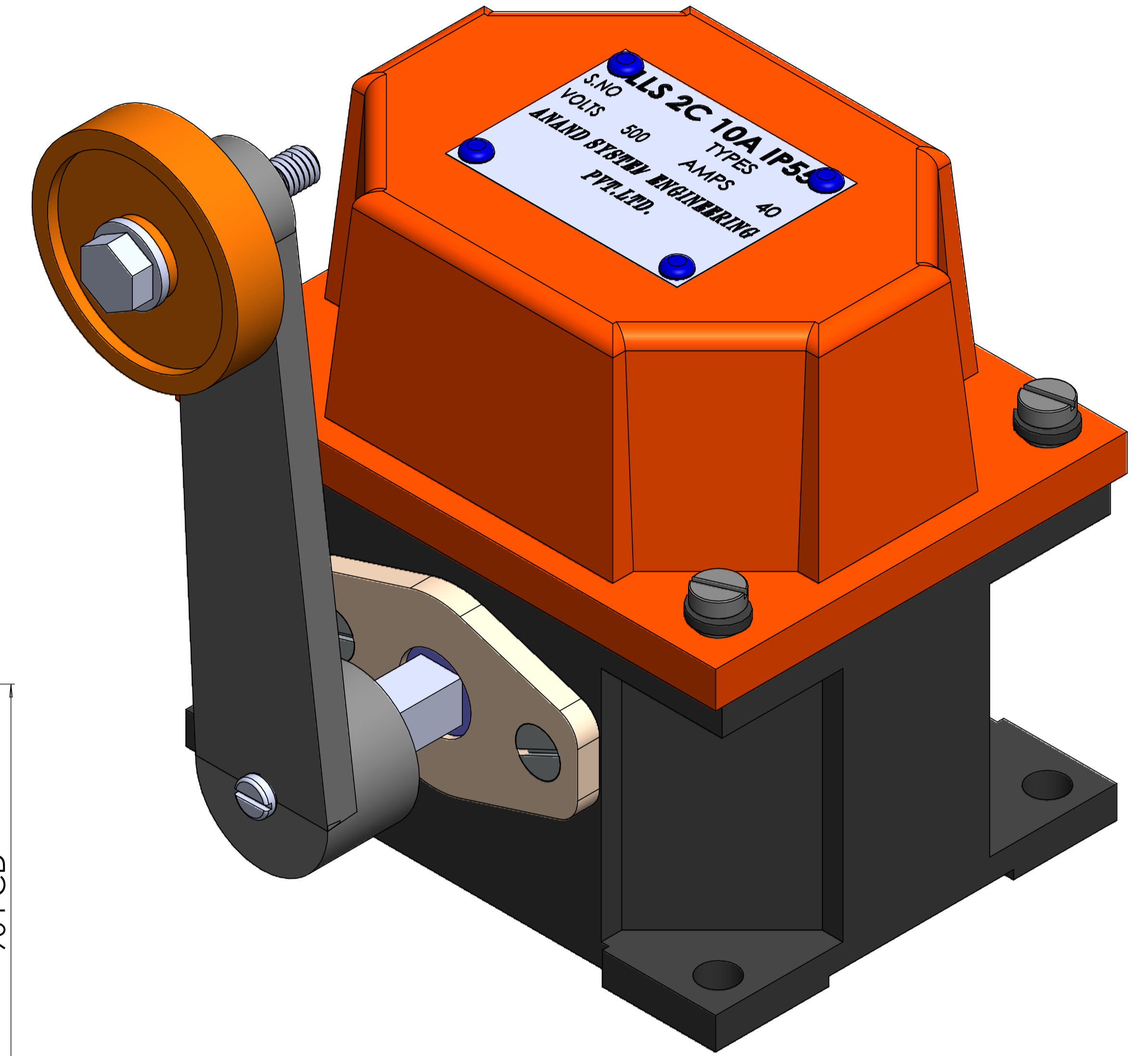
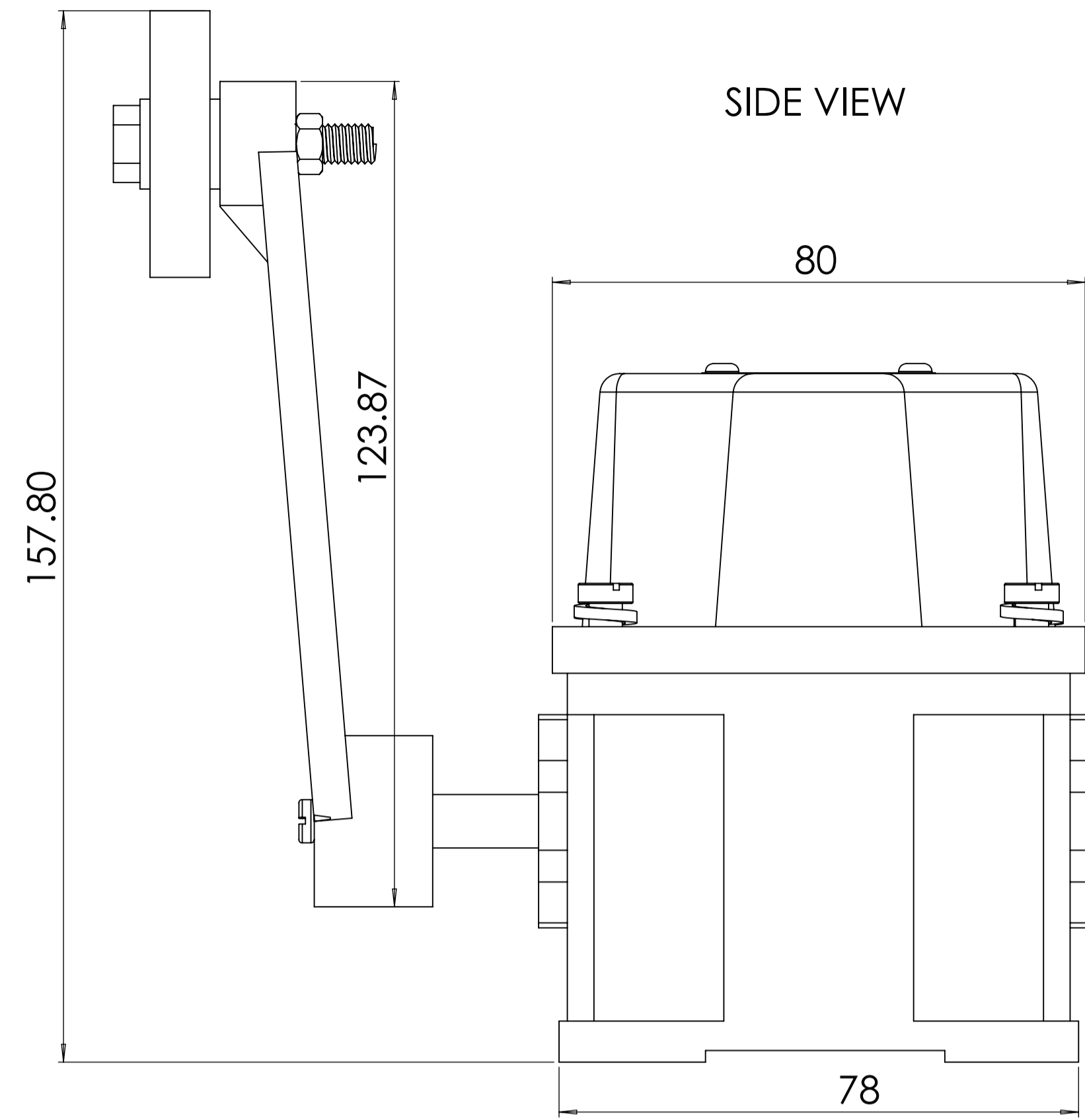

Ø 8.20X4 HOLES

Ø 4X4 HOLES

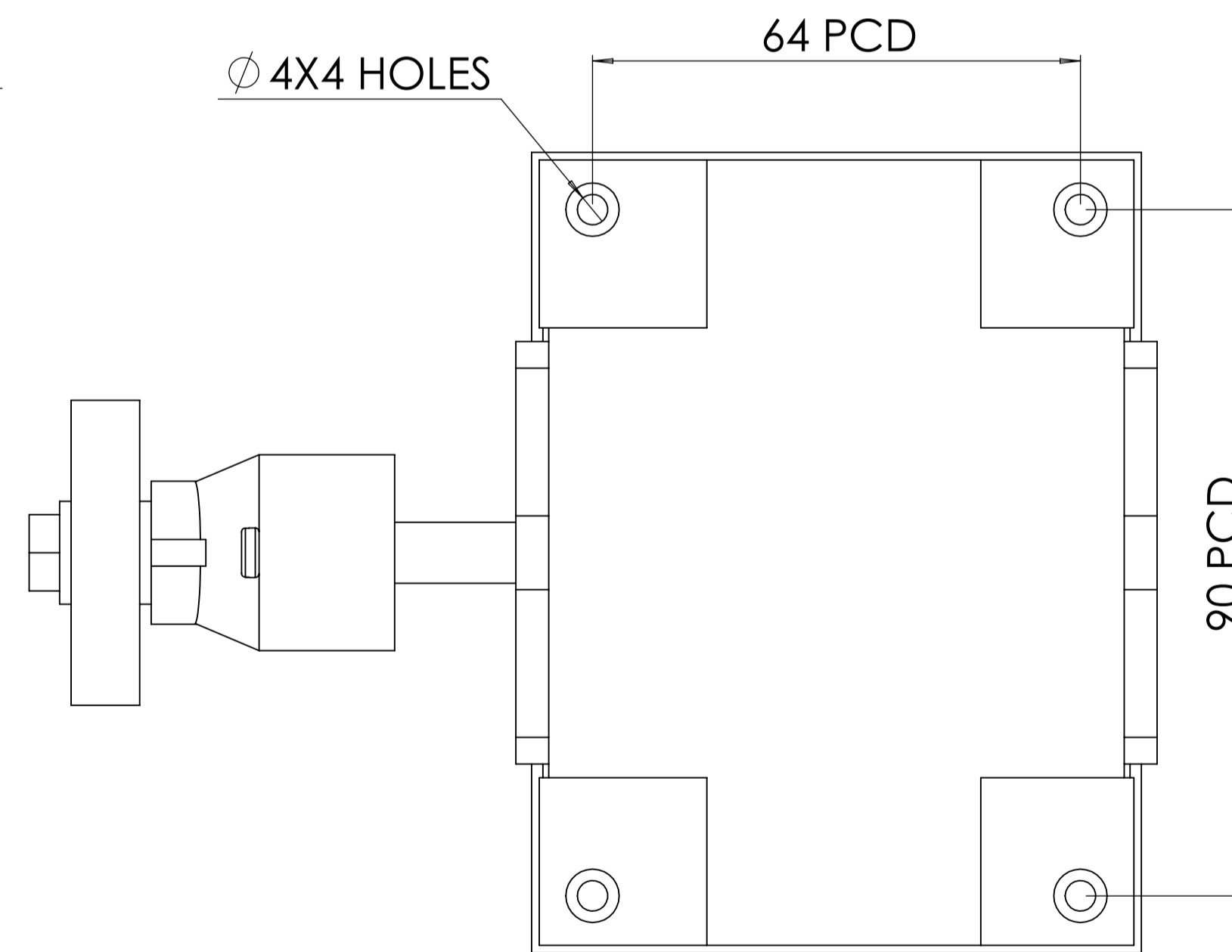
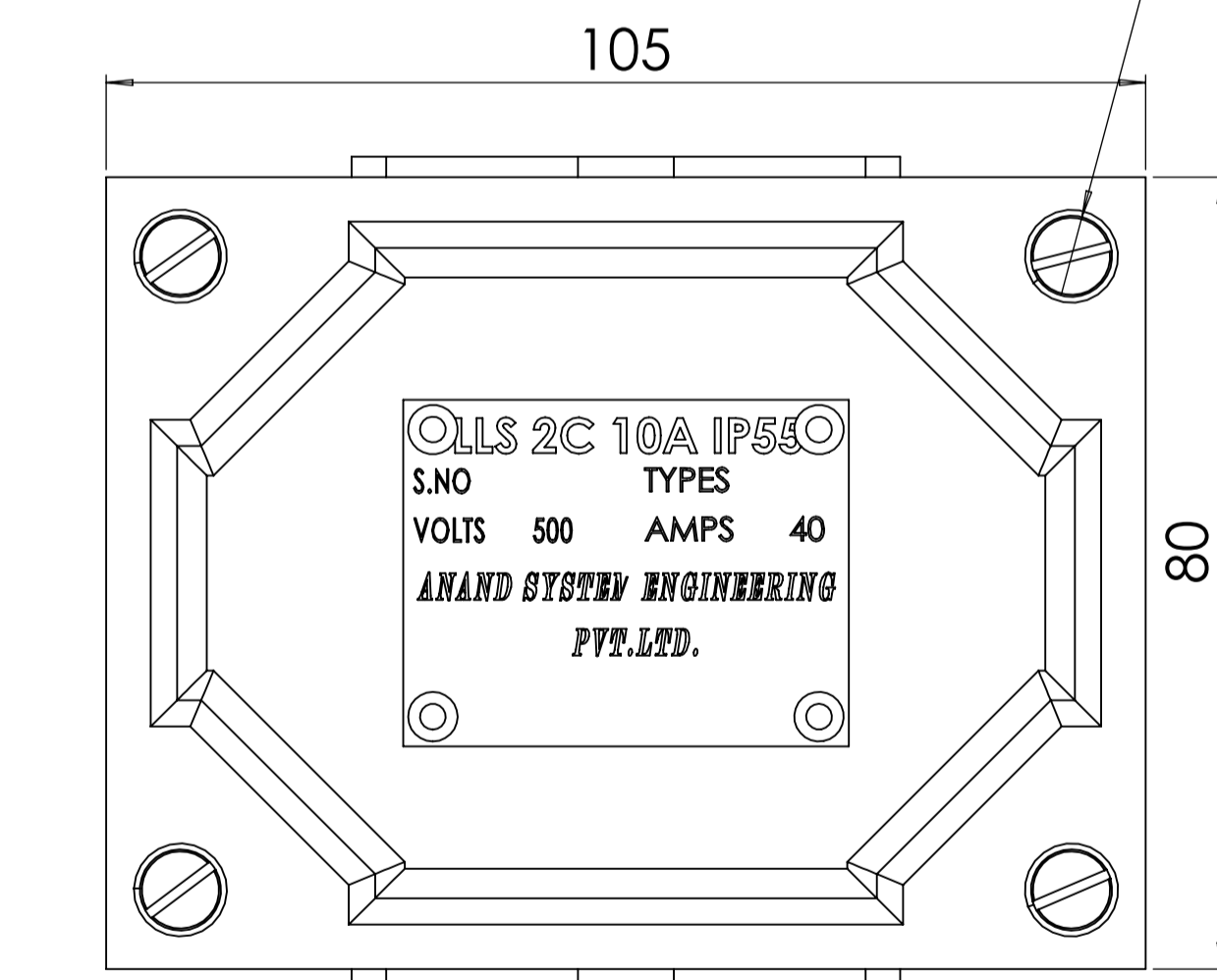

TOP VIEW

BOTTOM VIEW

COMPANY NAME:		ANAND SYSTEM ENGINEERING PVT LTD		DO NOT SCALE DRAWING	REVISION
		<b>ANAND SYSTEM ENGINEERING PVT LTD</b>		TITLE: LEVER LIMIT SWITCH 2C 10A IP-55 2D	
Email id: <a href="mailto:info@anandcontrol.in">info@anandcontrol.in</a>		CONTACT NO: 9137620579		DWG NO.	
DRAWN:		MATERIAL:		DATE	
CHKD:		WEIGHT:		SIGNATURE	
APPVD:		SCALE: 1:1		SHEET 2 OF 2	
G.A.				A1	