

EXPLODED VIEW

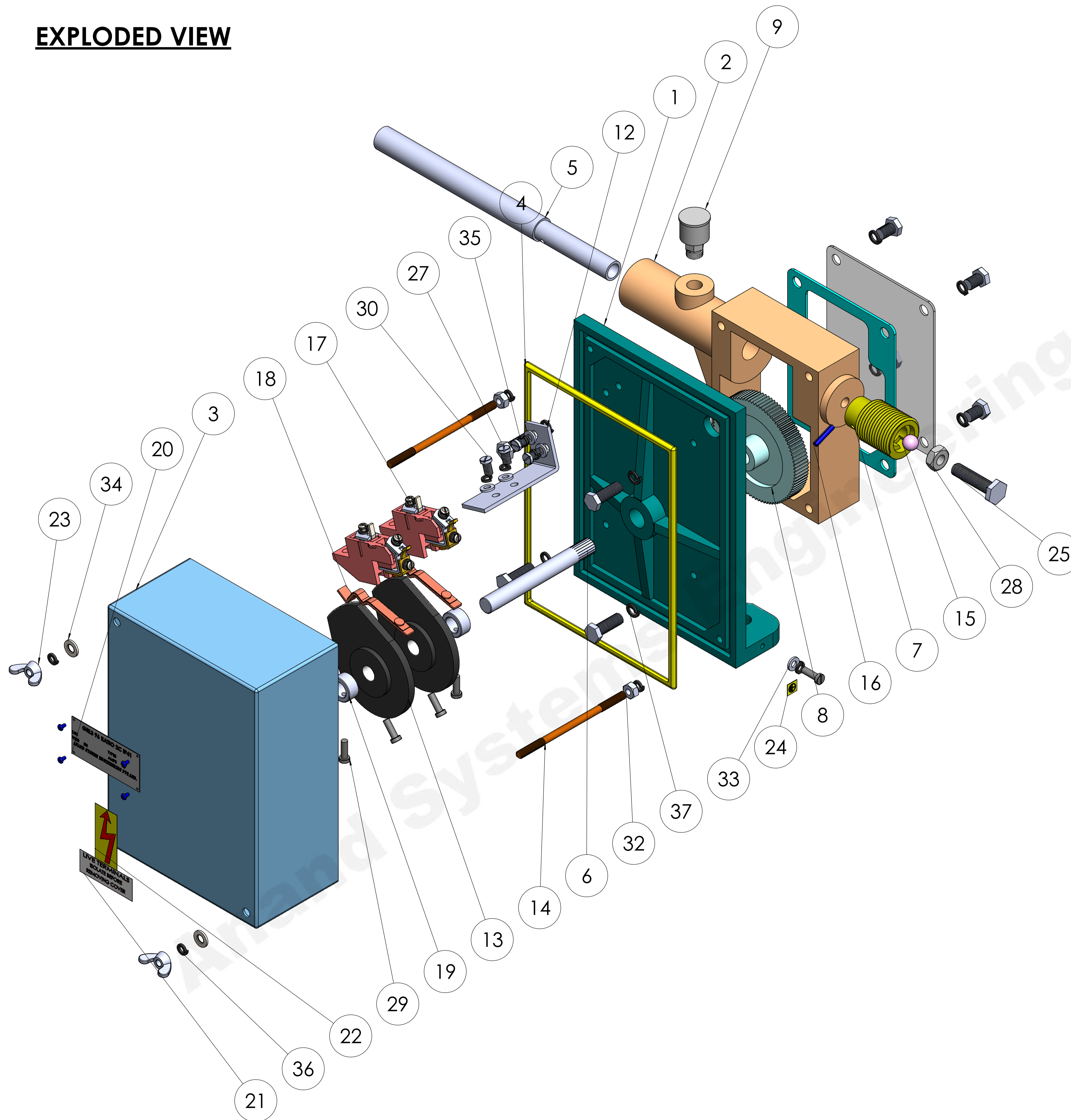
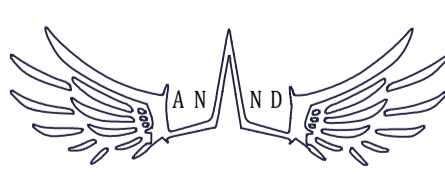

ITEM NO.	PART NAME	DESCRIPTION	Material	QTY.
1	RLS BOTTOM MAIN BODY	223X170X70	CAST IRON	1
2	RLS BOTTOM GEAR BOX	138X112X42.8, ϕ 40	CAST IRON	1
3	TOP COVER	217X157X86	M.S.	1
4	ROUND GASKET GEAR BOX	5MM	RUBBER	1
5	GEAR WARM SHAFT	ϕ 19X 245	M.S.	1
6	GEAR SHAFT	110X12.7	M.S.	1
7	GEAR WARM SHAFT CAP	ϕ 35 THREADING L- 49	PLASTIC	1
8	GEAR WORM WHEEL	RATIO 90:1, ϕ 87	N6	1
9	GREASE CAP	ϕ 22X18	PLASTIC	1
10	GEAR BOX COVER	140X110	M.S.	1
11	GASKET	MAIN BODY, 140X110X2	RUBBER	1
12	L- BRACKET	70X18.5X4 CONTACT ASSM FIXING	ALUMINIUM	1
13	MOLDED CAM	ϕ 77	N6	2
14	STUD	1/4"X110 MM	M.S.	2
15	STEEL BALL	ϕ 12	STEEL	1
16	TUBLER PIN	4X20 SHAFT FIXING TUBLER PIN	SPRING STEEL	1
17	CONTACT BLOCK	CONTACT BLOCK ASSEMBLY IP-41 40AMP	-	2
18	CONTACT STRIP	CONTACT FIXING STRIPS	M.S.	2
19	BUSH	19X10X1/2" CAM FIXING	M.S.	2
20	NAME PLATE	72X34 (4 HOLES 2MM)	ALUMINIUM	1
21	TERMINAL STICKER	TERMINAL STICKER	PVC	1
22	ARROW STICKER	ARROW STICKER	-	1
23	BUTTERFLY NUT	1/4 MM COVER FIXING	M.S.	2
24	ERTHING STICKER	ERTHING LEVEL	-	1
25	BOLT	10X40	M.S.	1
26	BOLT	8X12	M.S.	4
27	BOLT	8X25	M.S.	4
28	HEX NUT-M10	M 10 G.I.	M.S.	1
29	IMPELLER COVER AND TERMINAL SCREW	CHHS 5X15	M.S.	5
30	SCREW	CHEESED M6X15	M.S.	4
31	NAME PLATE RIVET	AB4	ALUMINIUM	4
32	NUT 1-4	RB-1/4 NUT	M.S.	2
33	PLAIN WASHER	11X5.5X1.5	M.S.	5
34	PLAIN WASHER	13.5X6X1.5	M.S.	2
35	SPRING WASHER M5	M5X8.7X1.7	SPRING STEEL	4
36	SPRING WASHER	M6	SPRING STEEL	5
37	SPRING WASHER	M8	SPRING STEEL	8

COMPANY NAME:  ANAND SYSTEM ENGINEERING PVT LTD

DO NOT SCALE DRAWING

TITLE: GRLS 90 RATIO 2C IP-41 ASSEMBLY 2D

EMAIL ID: info@anandcontrol.in

CONTACT NO: 9137620579

SCALE: 1:1

SHEET: 1 OF 1

TOP VIEW

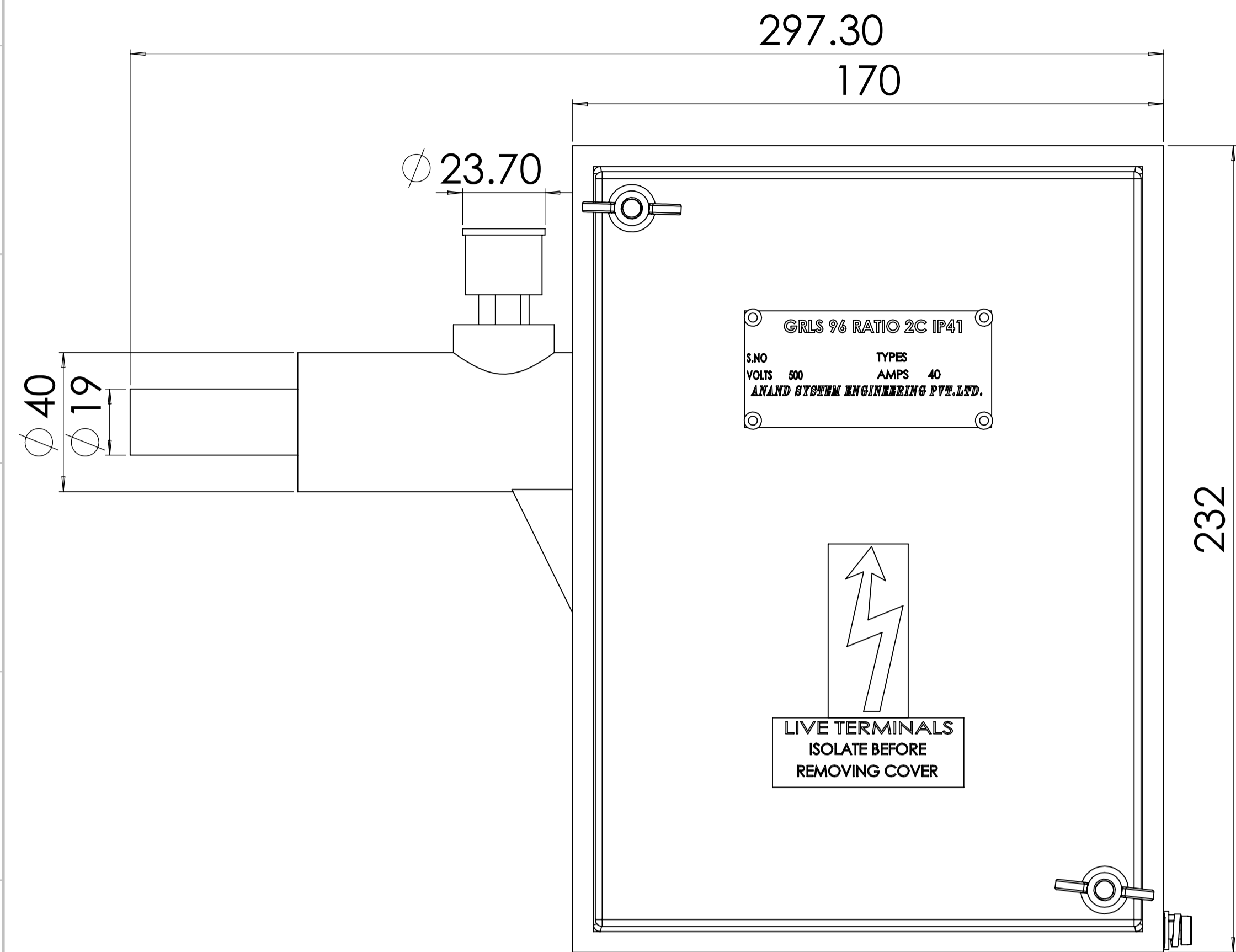

BOTTOM VIEW

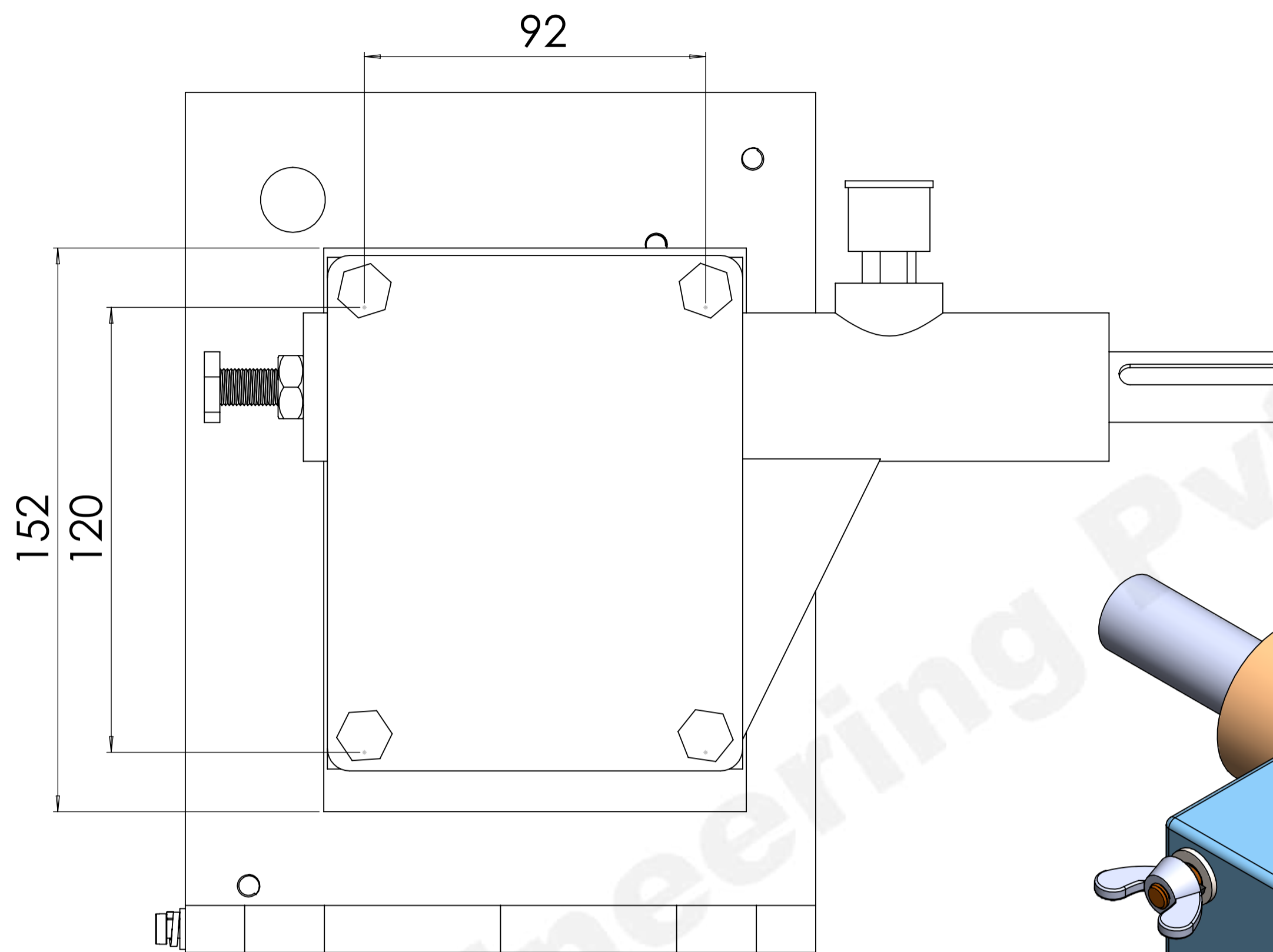

FRONT VIEW

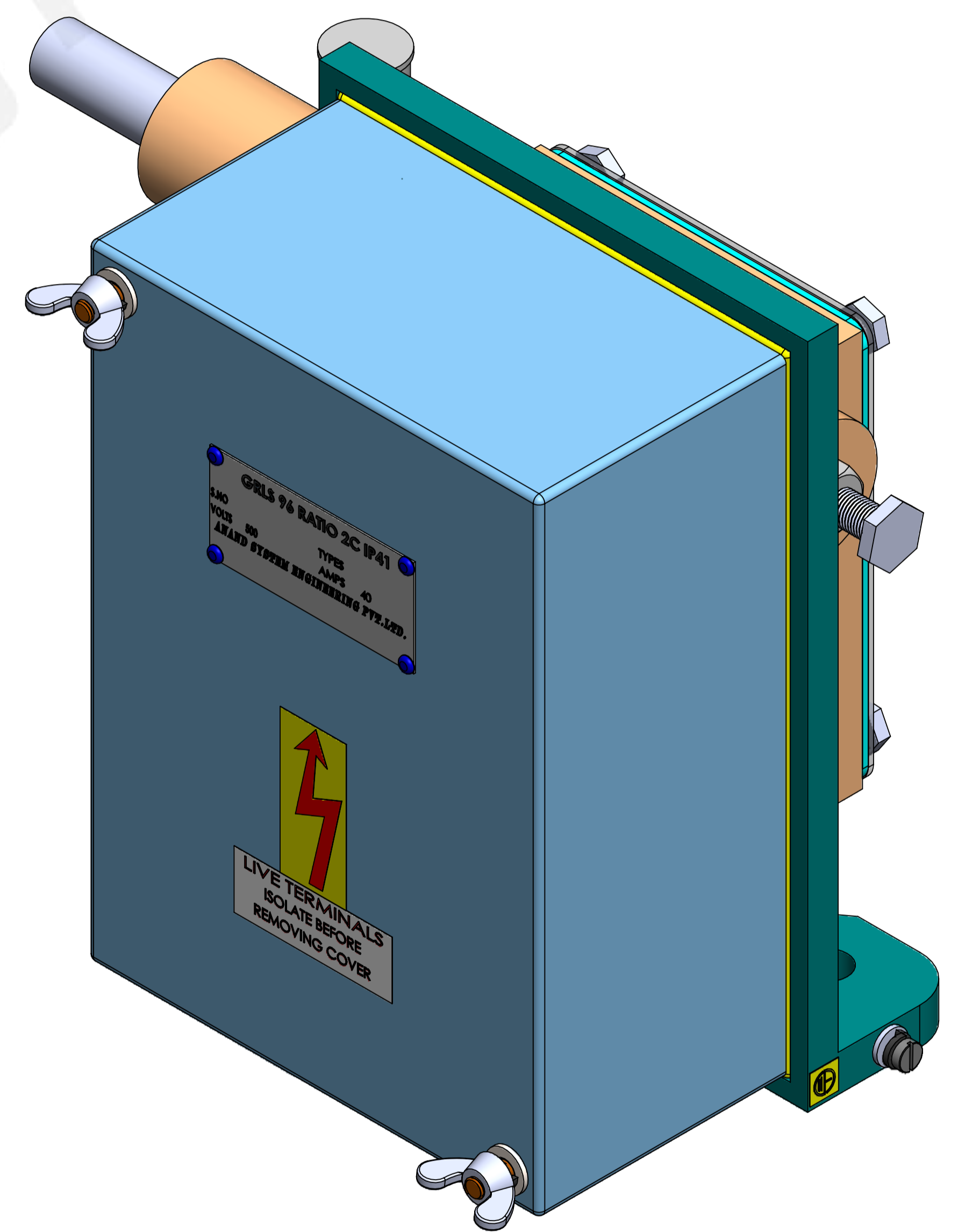
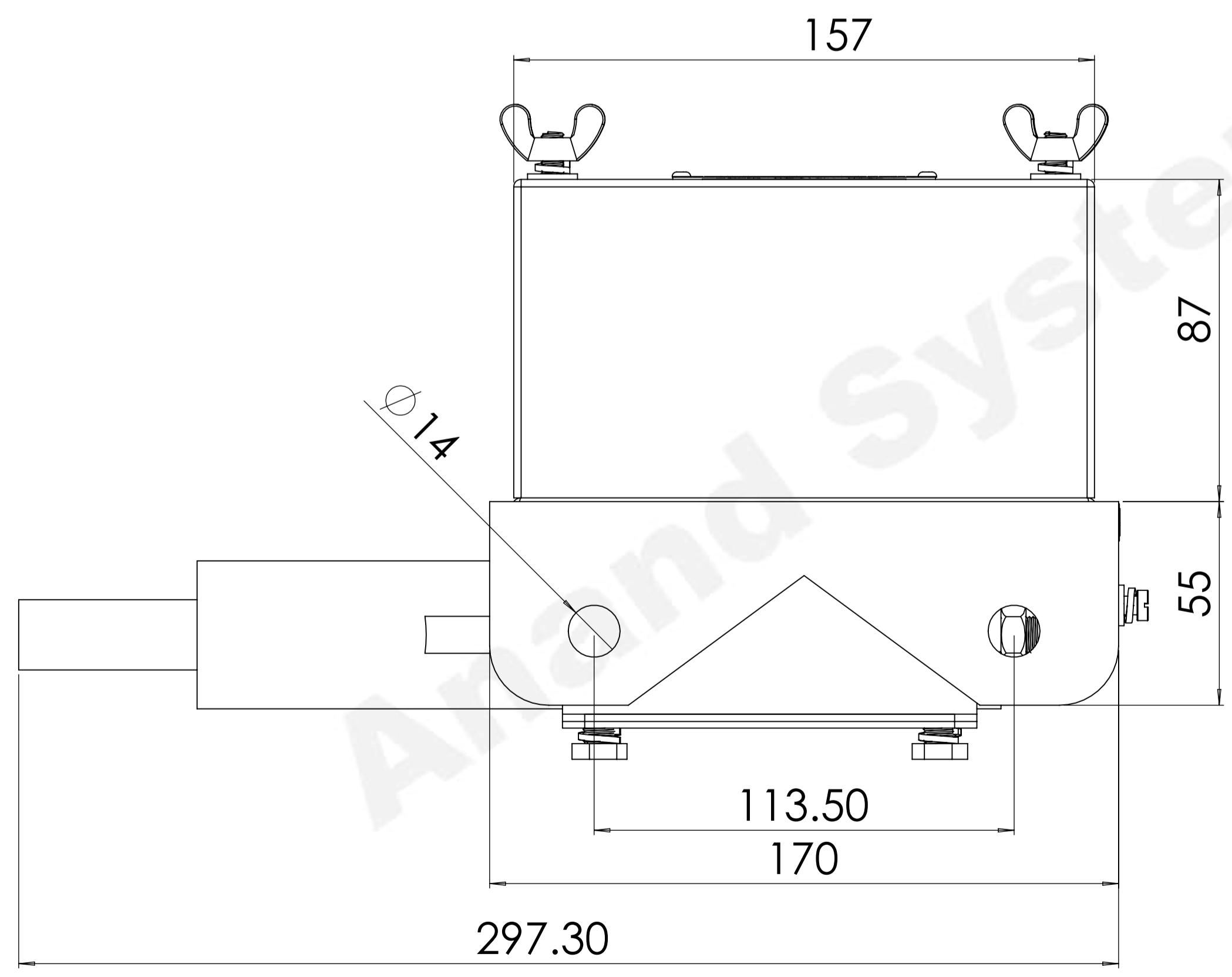

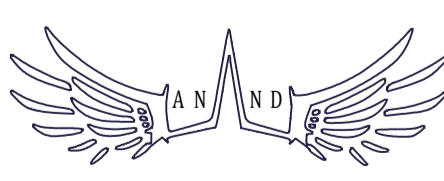
COMPANY NAME:  ANAND SYSTEM ENGINEERING PVT LTD		DO NOT SCALE DRAWING	REVISION:
Email id: info@anandcontrol.in		TITLE: GRLS 90 RATIO 2C IP-41 ASSEMBLY 2D	
CONTACT NO: 9137620579		DWG NO.:	
DATE:	SIGNATURE:	SCALE:	
DRWN: SAURABH	CHECK:	MATERIAL:	A
APPR:	WEIGHT:	SHEET: 1 OF 1	