

EXPLODED VIEW

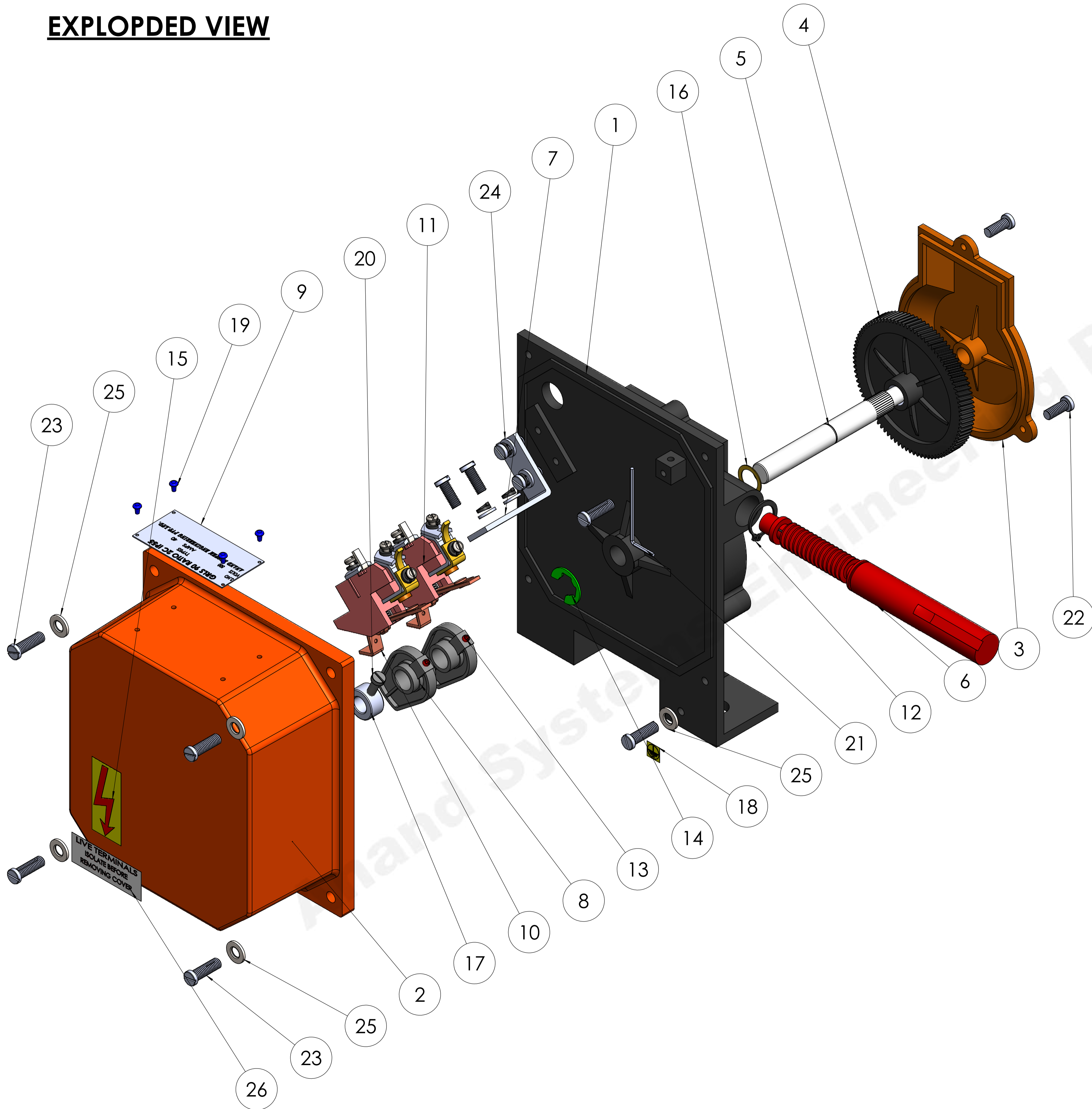

ITEM NO.	PART NAME	DESCRIPTION	Material	QTY.
1	BOTTOM COVER	205X158X46	ALUMINIUM DIE CAST	1
2	TOP COVER	174X158X76	ALUMINIUM DIE CAST	1
3	GEAR BOX COVER	Ø 104, 123X73	N6	1
4	GEARS WARM WHEEL	90:1 , 86.5X12.7	N6	1
5	GEAR WORM SHAFT	110X12.75	M.S.	1
6	WARM SHAFT	19X175	M.S.	1
7	L-BRACKET	BRACKET CONTACT FIXING	M.S.	1
8	MOLDED CAM	Ø 12.7	PLASTIC	2
9	NAME PLATE	71X33X0.5 (4 HOLES 2MM)	ALUMINIUM	1
10	CONTACT STRIP	CONTACT BREAK STRIP	BRASS	2
11	CONTACT BLOCK	CONTACT BLOCK ASSEMBLY IP-4140AMP	-	2
12	RING TYPE CIRCLIP	Ø 17 GEAR WORM SHAFT	STAINLESS STEEL	1
13	ALLENKEY SCREW	4X12	M.S.	2
14	E CIRCLIP	11.5 GEAR SHAFT	CARBON STEEL	1
15	ARROW STICKER	ARROW STICKER	PVC	1
16	BRASS WASHER	18X13X0.5	BRASS	1
17	BUSH	19X10X1/2" CAM FIXING	M.S.	1
18	ERTHING STICKER	ERTHING STICKER	PVC	1
19	RIVET AB4	NAME PLATE RIVET	ALUMINIUM	4
20	SCREW	5X15	M.S.	1
21	M2 ALLENKEY	CAM FIXING	M.S.	1
22	SCREW	CHEESED M6 6X15	M.S.	7
23	SCREW	CHEESED M6 6X20	M.S.	6
24	PLAIN WASHER	11X5.5X1.5	M.S.	4
25	PLAIN WASHER	11X5X1.5	M.S.	5
26	TERMINAL STICKER	TERMINAL STICKER	PVC	1
27	SPRING WASHER	A5	SPRING STEEL	4

 ANAND SYSTEM ENGINEERING PVT LTD		DO NOT SCALE DRAWING TITLE: GRLS 90 RATIO 2C IP55 2D
Email id: info@anandcontrol.in CONTACT NO: 9137620579		DWG NO: DATE: _____ SIGNATURE: _____
DRAWN: SAURABH CHECKED: APPROVED: MFC:	MATERIAL: WEIGHT:	SCALE: SHEET: 1 OF 1

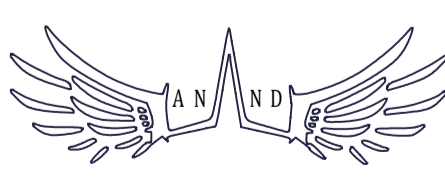
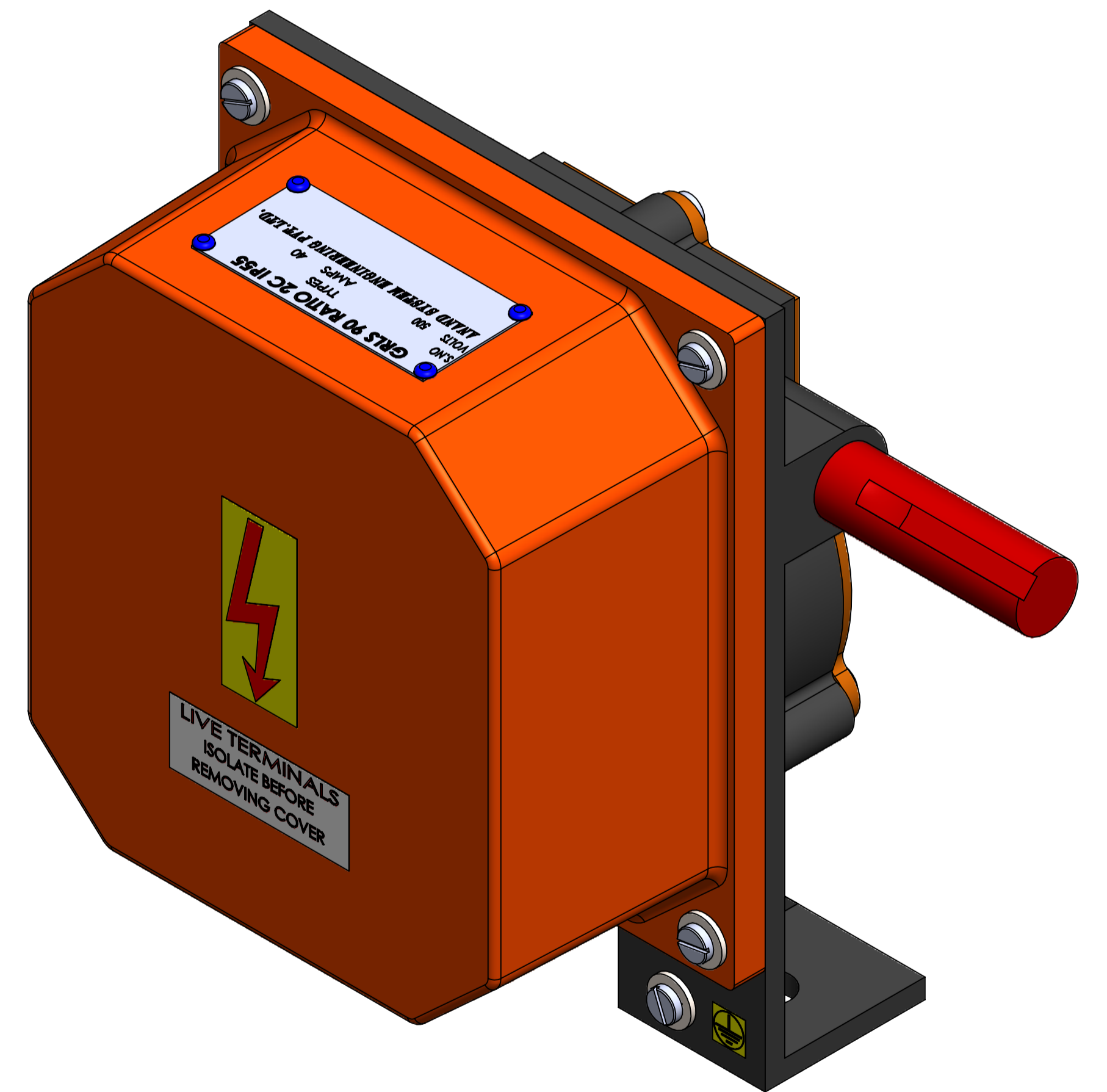
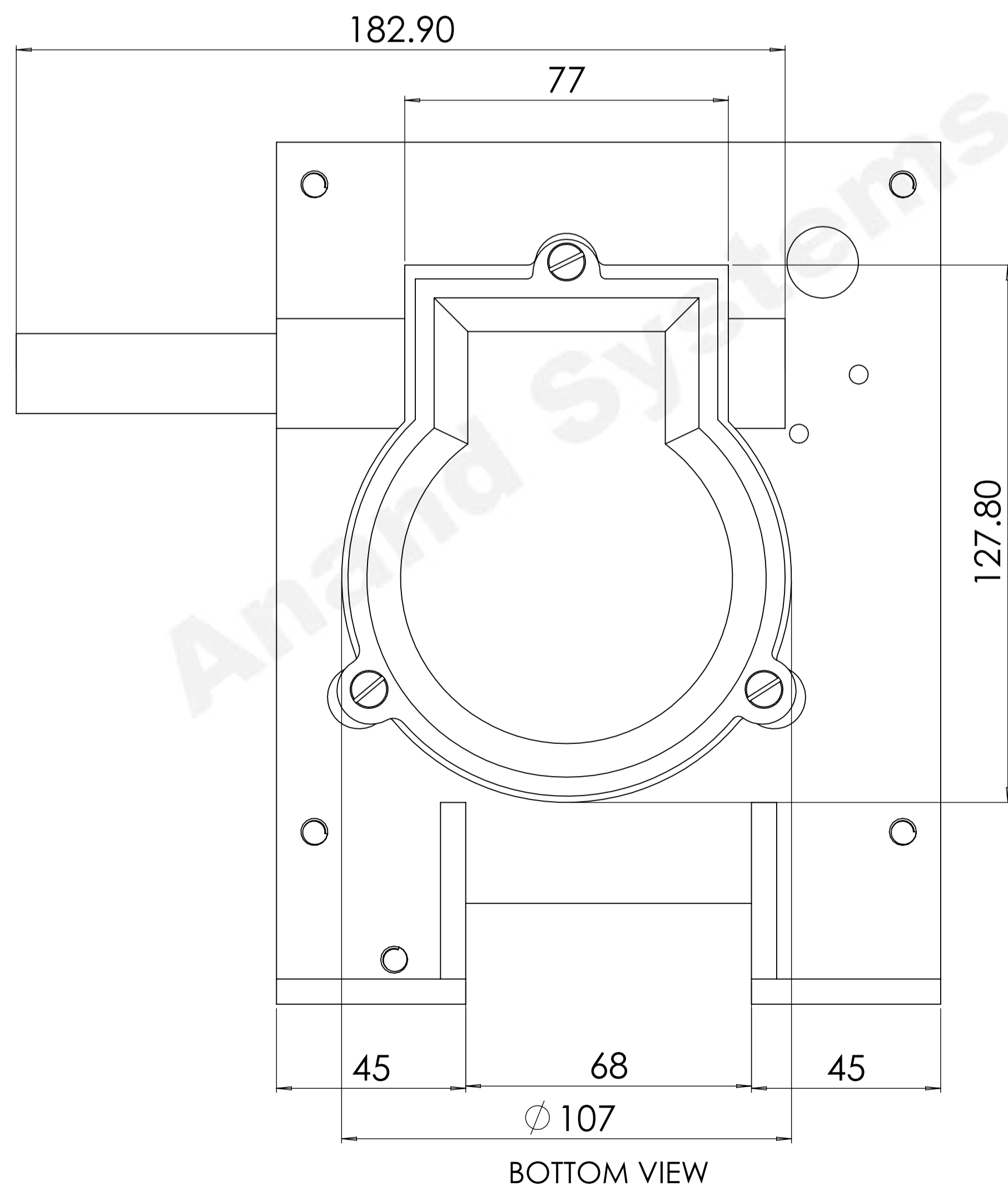
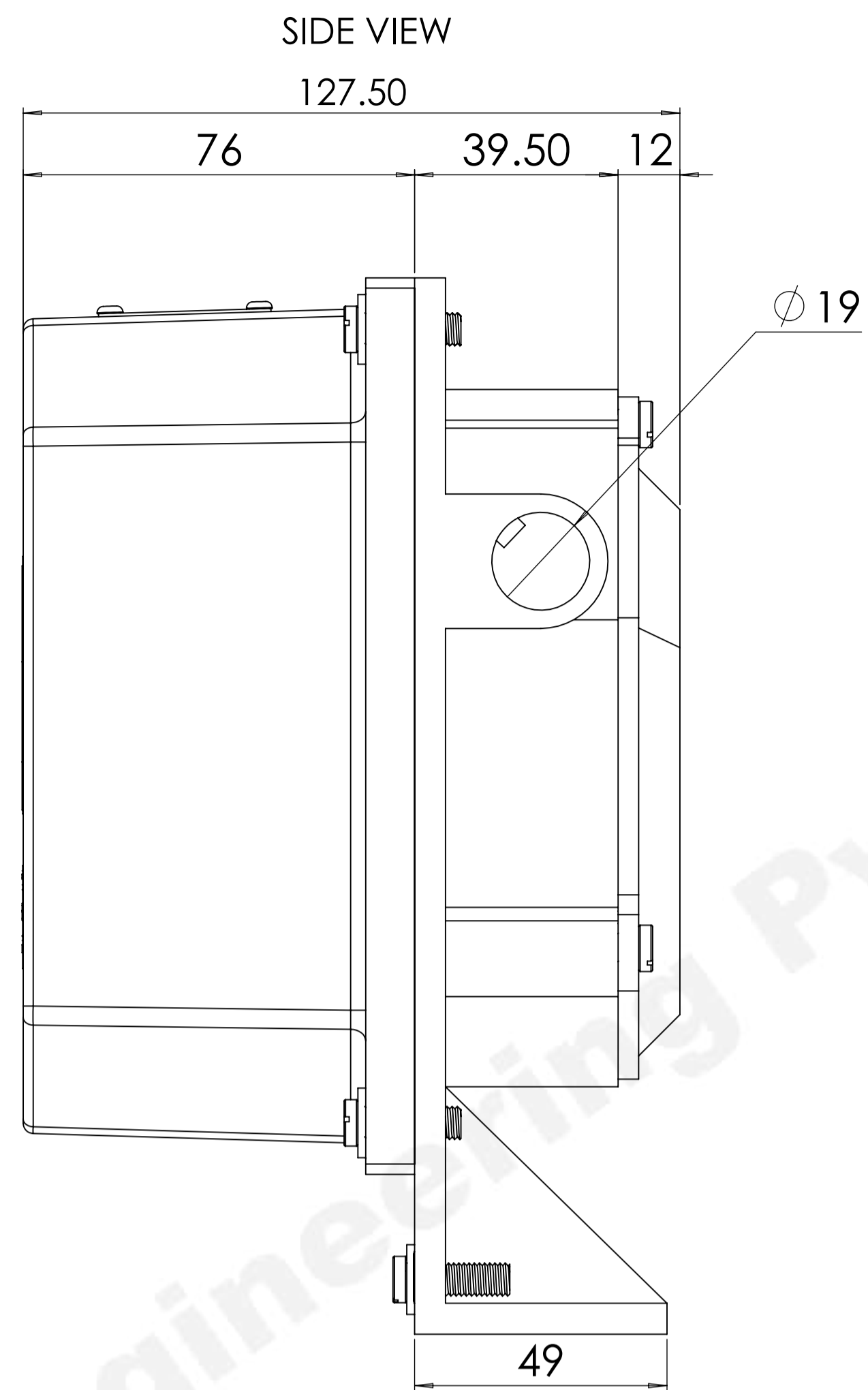
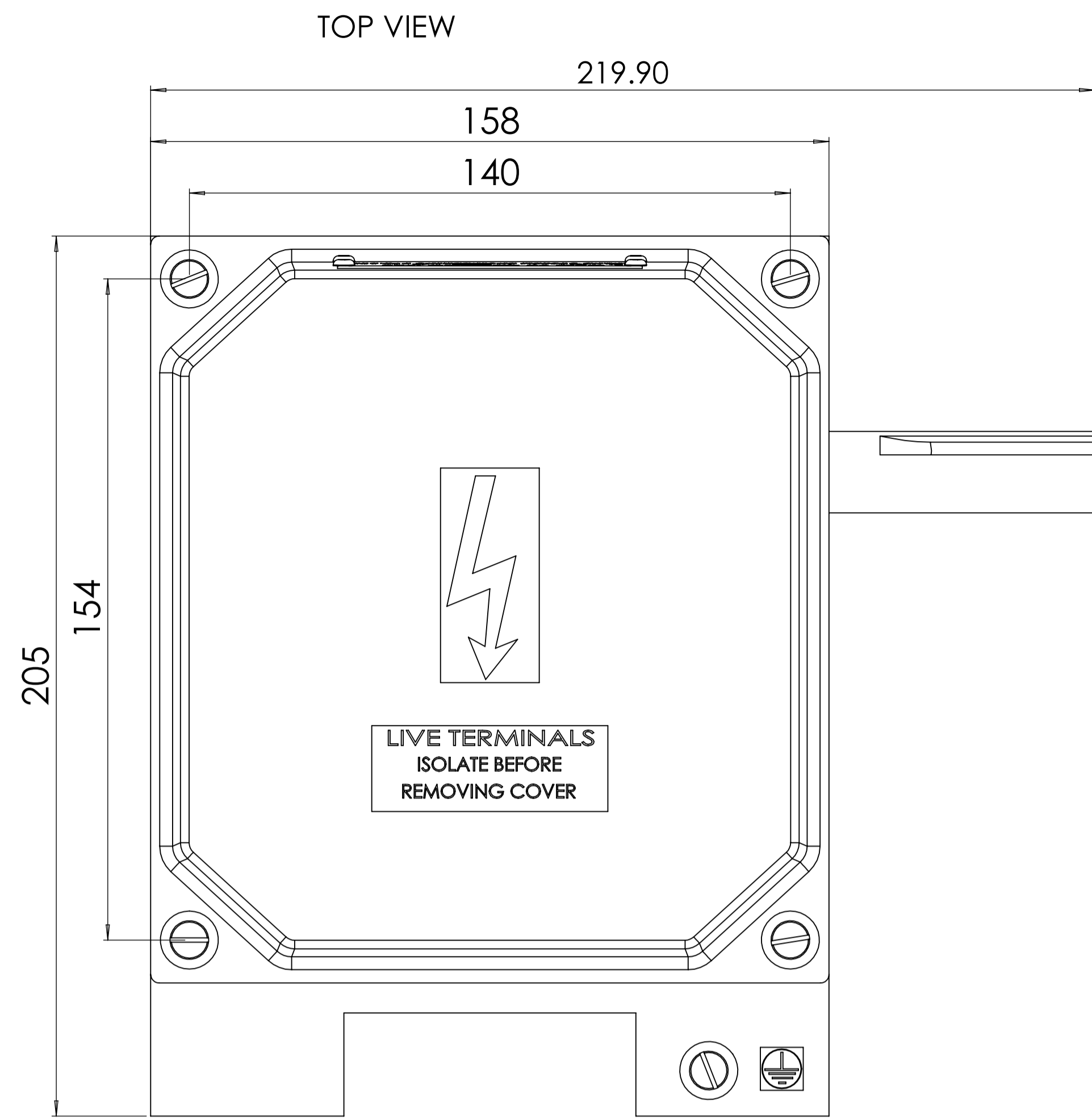

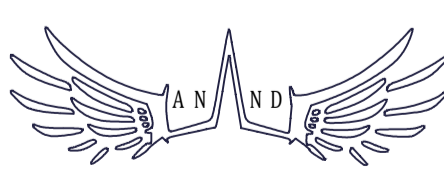
COMPANY NAME:		ANAND SYSTEM ENGINEERING PVT LTD		DO NOT SCALE DRAWING	REVISION:
		<p>EMAIL ID: info@anandcontrol.in</p> <p>CONTACT NO: 9137620579</p>		<p>TITLE:</p> <p>GRLS 90 RATIO 2C IP55 2D</p>	
DATE:	SIGNATURE:	FINISH:		DWG. NO.:	
SCALE:	SHEET: 1 OF 1	MATERIAL:		A	