

# EXPLODED VIEW

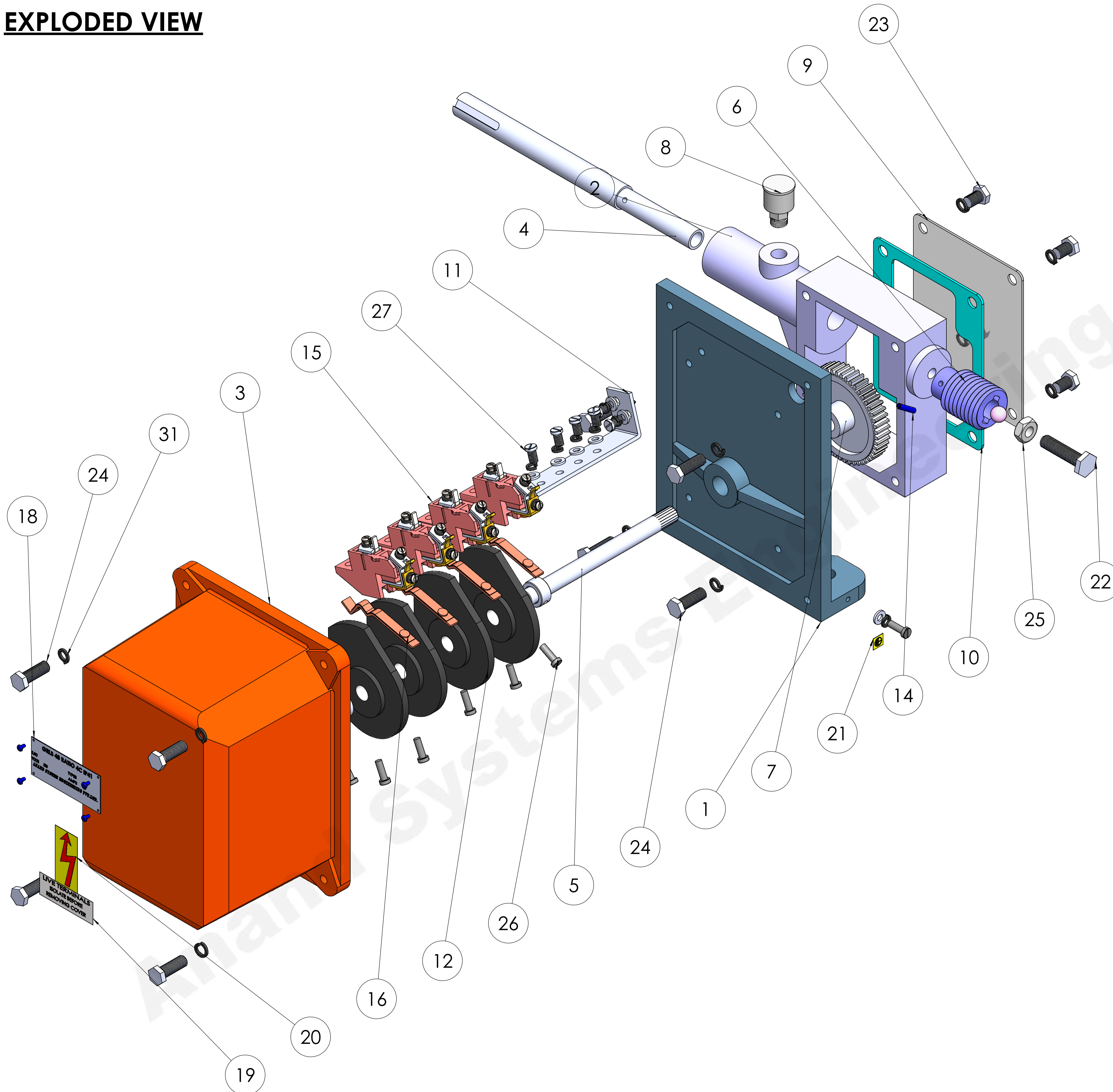

ITEM NO.	PART NAME	DESCRIPTION	Material	QTY.
1	RLS BOTTOM MAIN BODY	223X170X70	CAST IRON	1
2	RLS BOTTOM GEAR BOX	112X138X212	CAST IRON	1
3	TOP COVER	174X158X76	ALUMINIUM DIE CAST	1
4	GEAR WARM SHAFT	Ø19X 245	M.S.	1
5	GEAR SHAFT	110X12.7	M.S.	1
6	GEAR WARM SHAFT CAP	Ø35 THREADING L- 49	PLASTIC	1
7	GEAR WORM WHEEL	RATIO 48:1, Ø78	N6	1
8	GREASE CAP	Ø22X18	PLASTIC	1
9	GEAR BOX COVER	140X110	M.S.	1
10	GASKET	MAIN BODY, 140X110X2	RUBBER	1
11	L- BRACKET	123.5X18.5X4 CONTACT ASSM FIXING	ALUMINIUM	1
12	MOLDED CAM	Ø77	N6	4
13	STEEL BALL	Ø12	STEEL	1
14	TUBLER PIN	4X20 SHAFT FIXING TUBLER PIN	SPRING STEEL	1
15	CONTACT BLOCK	CONTACT BLOCK ASSEMBLY IP-4140AMP	-	4
16	CONTACT STRIP	CONTACT FIXING STRIPS	M.S.	4
17	BUSH	19X10X1/2" CAM FIXING	M.S.	2
18	NAME PLATE	72X34 (4 HOLES 2MM)	ALUMINIUM	1
19	TERMINAL STICKER	TERMINAL STICKER	PVC	1
20	ARROW STICKER	ARROW STICKER	PVC	1
21	ERTHING STICKER	ERTHING LEVEL	PVC	1
22	BOLT	10X40	M.S.	1
23	BOLT	8X12	M.S.	4
24	BOLT	8X25	M.S.	8
25	HEX NUT-M10	M 10 G.I.	M.S.	1
26	IMPELLER COVER AND TERMINAL SCREW	CHHS 5X15	M.S.	7
27	SCREW	CHEESED HEAD M6X15	M.S.	6
28	NAME PLATE RIVET	AB4	ALUMINIUM	4
29	PLAIN WASHER	11X5.5X1.5	M.S.	7
30	SPRING WASHER M5	M5X8.7X1.7	SPRING STEEL	6
31	SPRING WASHER	M8	SPRING STEEL	12
32	SPRING WASHER	M6	SPRING STEEL	1

COMPANY NAME: **ANAND SYSTEM ENGINEERING PVT LTD**

DO NOT SCALE DRAWING

TITLE: **GRLS 48 RATIO 4C IP-55 ASSEMBLY 2D**

Email id: [info@anandcontrol.in](mailto:info@anandcontrol.in)

CONTACT NO: 9137620579

DATE: \_\_\_\_\_ SIGNATURE: \_\_\_\_\_

SCALE: 1:2 SHEET 1 OF 2

16 15 14 13 12 11 10 9 8 7 6 5 4 3 2 1

M L K J H G F E D C B A

**TOP VIEW**

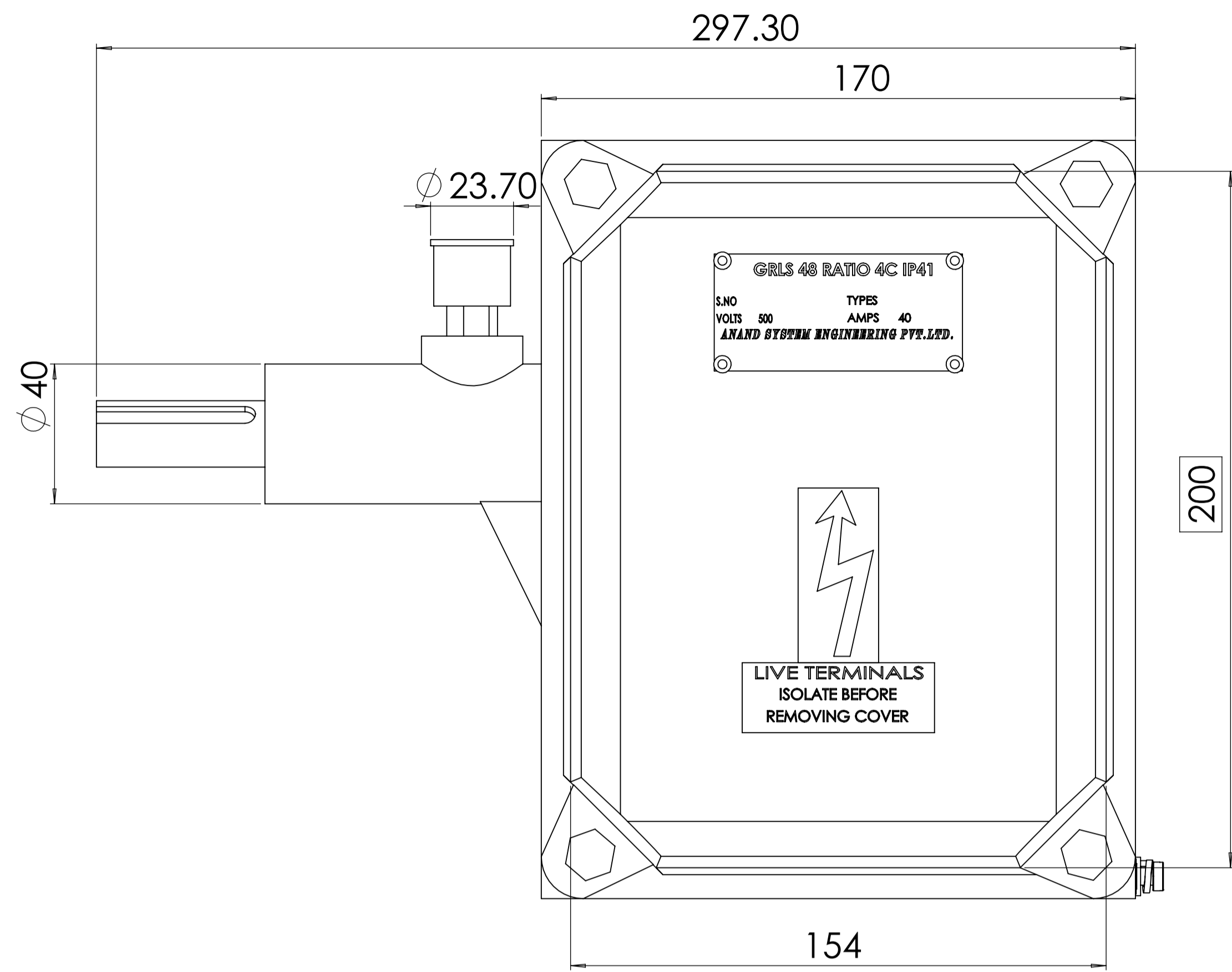

**BOTTOM VIEW**

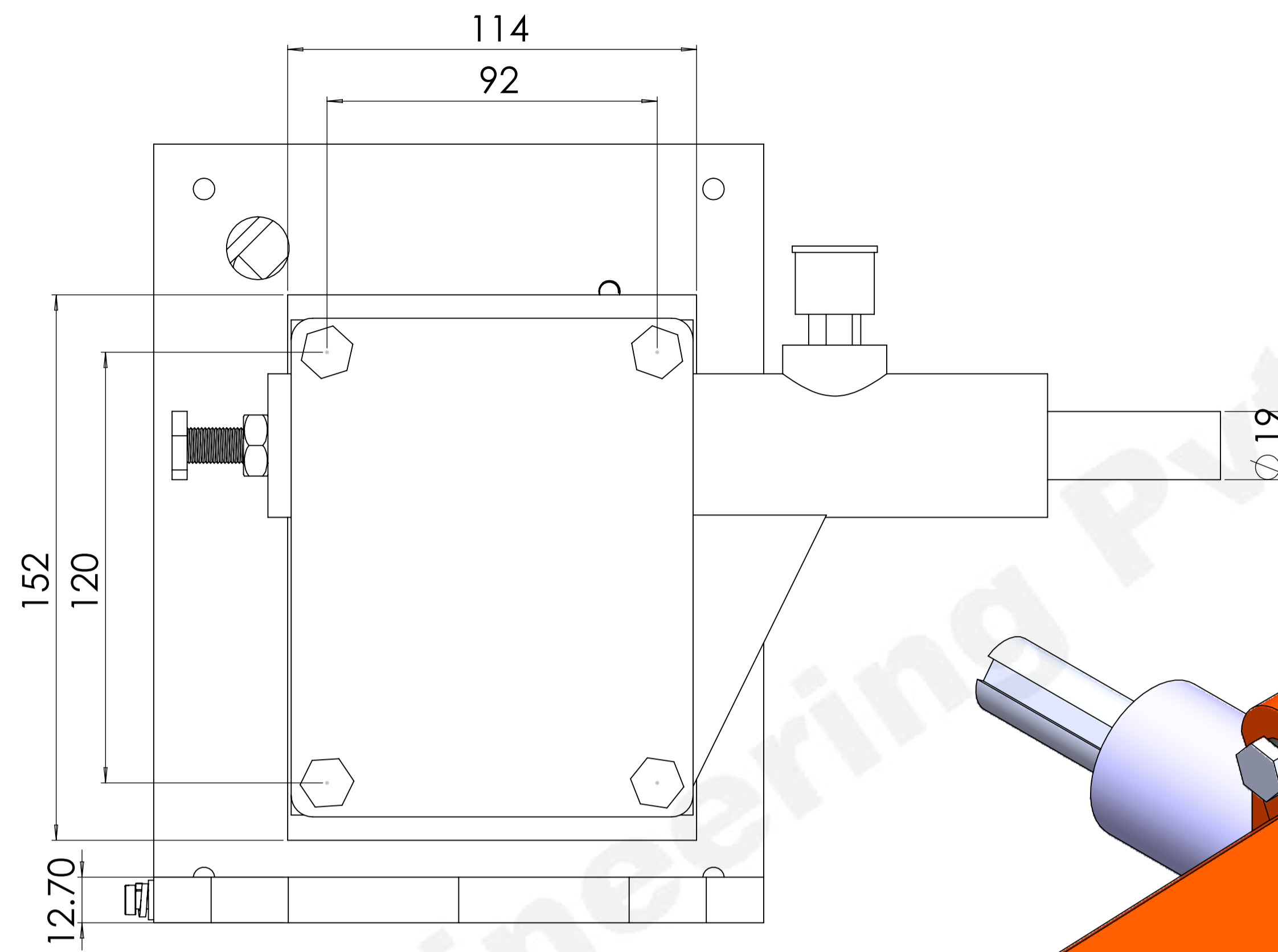

**FRONT VIEW**

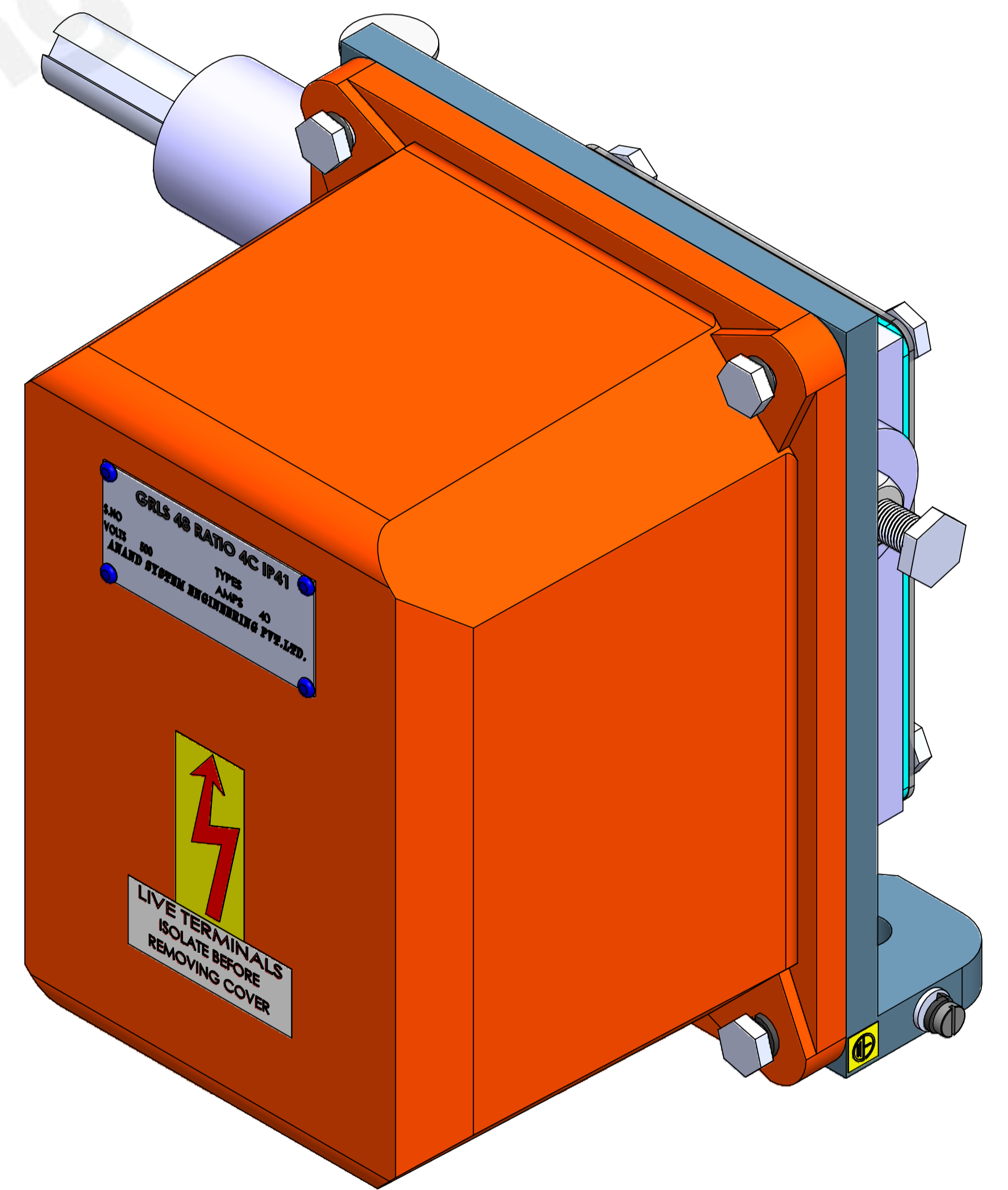
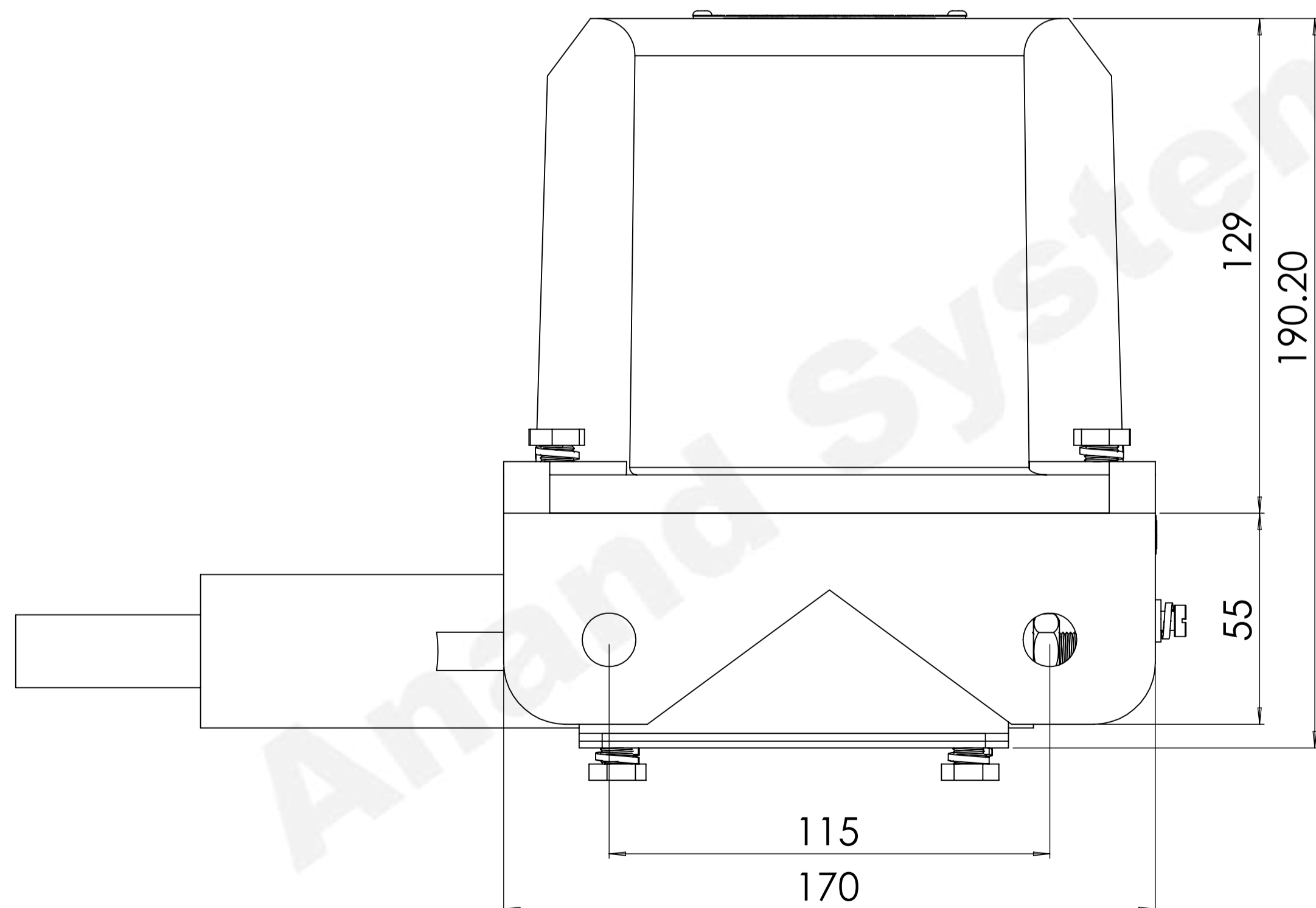

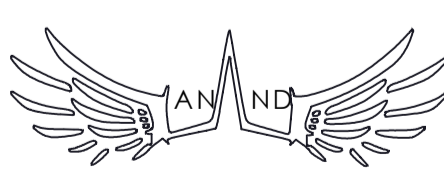
COMPANY NAME:		ANAND SYSTEM ENGINEERING PVT LTD		DO NOT SCALE DRAWING	REVISION
		<b>ANAND SYSTEM ENGINEERING PVT LTD</b>		TITLE:	
Email id: <a href="mailto:info@anandcontrol.in">info@anandcontrol.in</a>		CONTACT NO : 9137620579		GRLS 48 RATIO 4C IP-55 ASSEMBLY 2D	
DRAWN:	SAURABH	MATERIAL:		DATE:	SIGNATURE
CHK'D:		WEIGHT:		SCALE: 1:2	SHEET 2 OF 2
APP'VD:					
G.A.					

16 15 14 13 12 11 10 9 8 7 6 5 4 3 2 1