

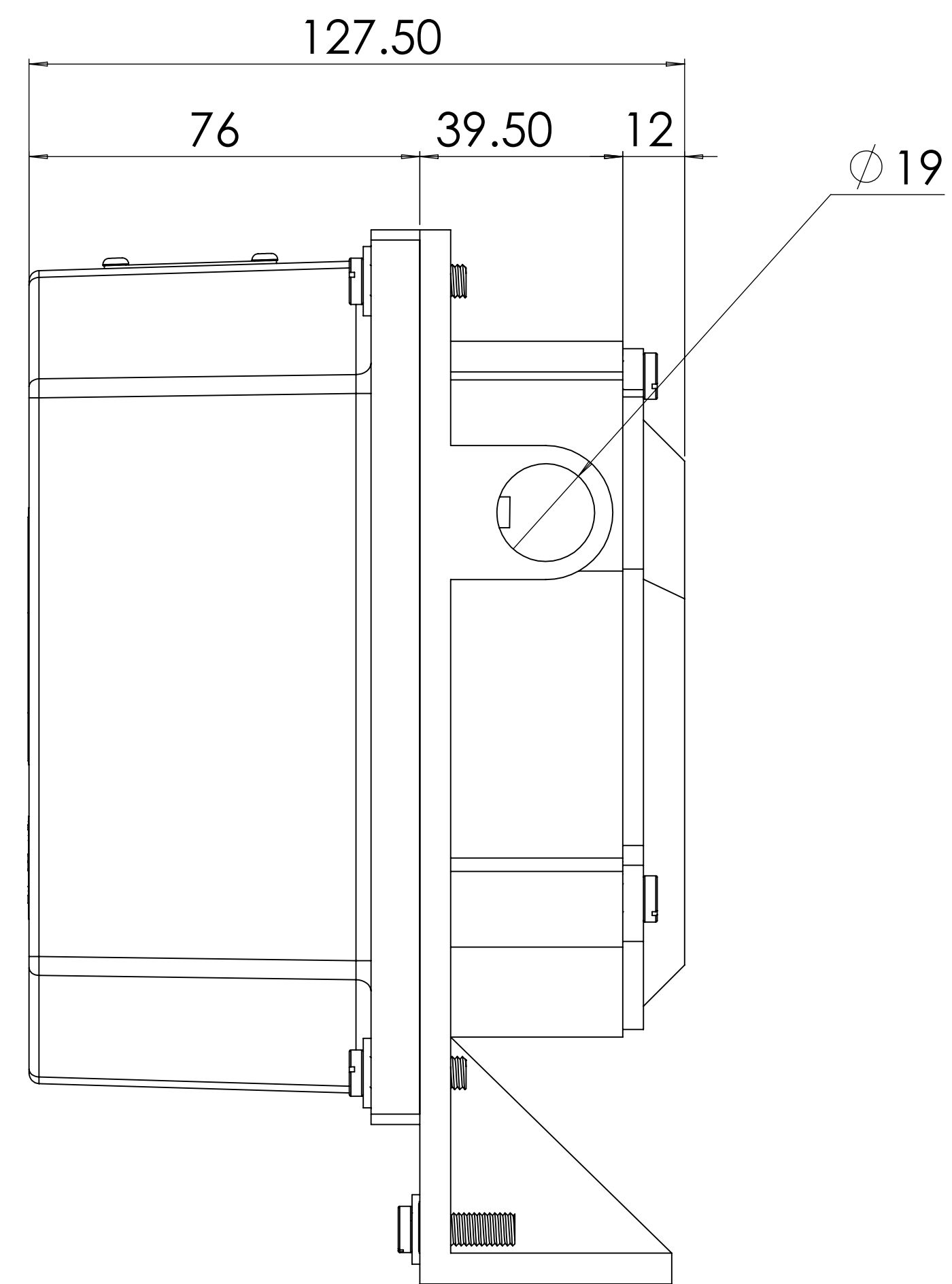

TOP VIEW

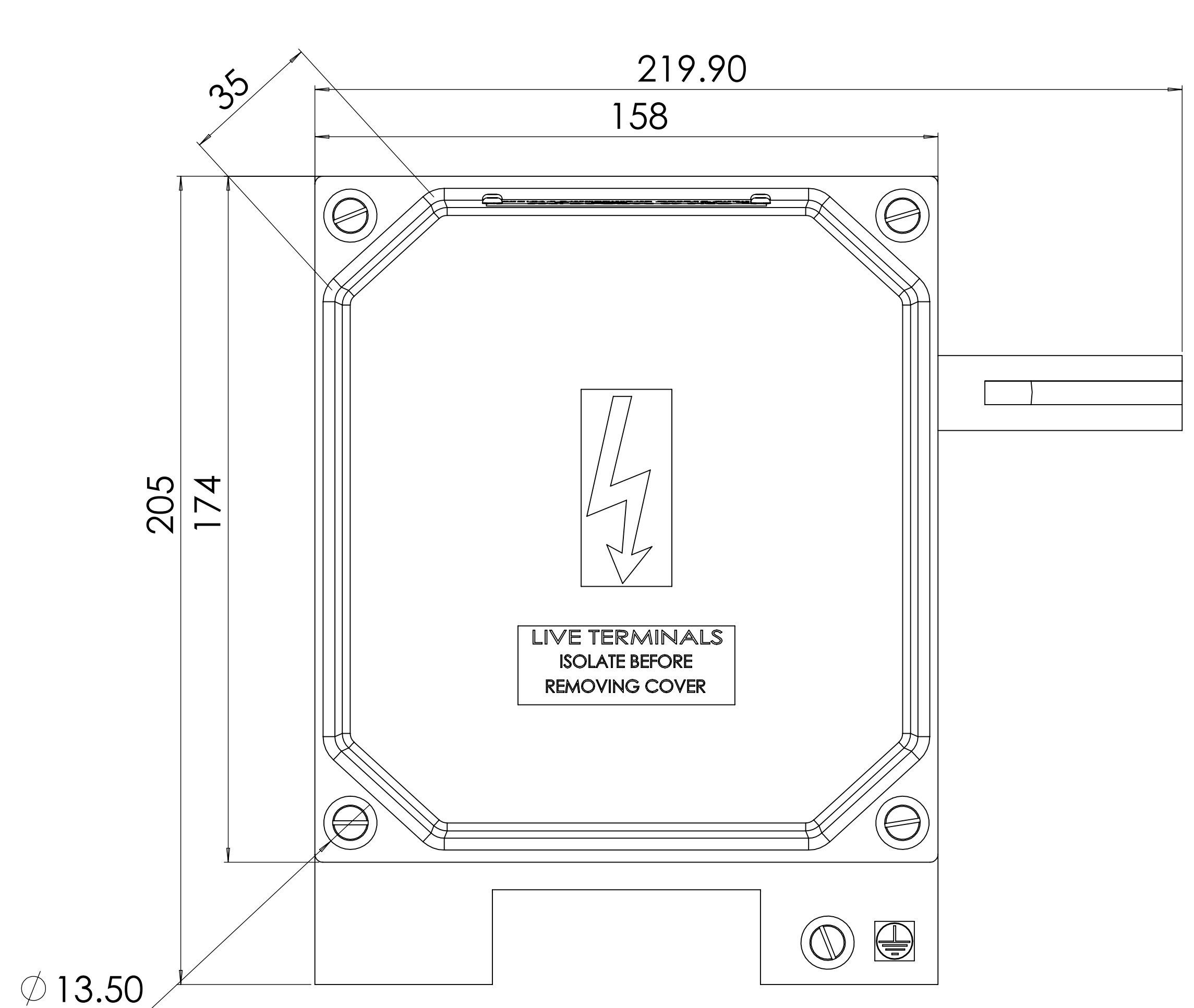

BOTTOM VIEW

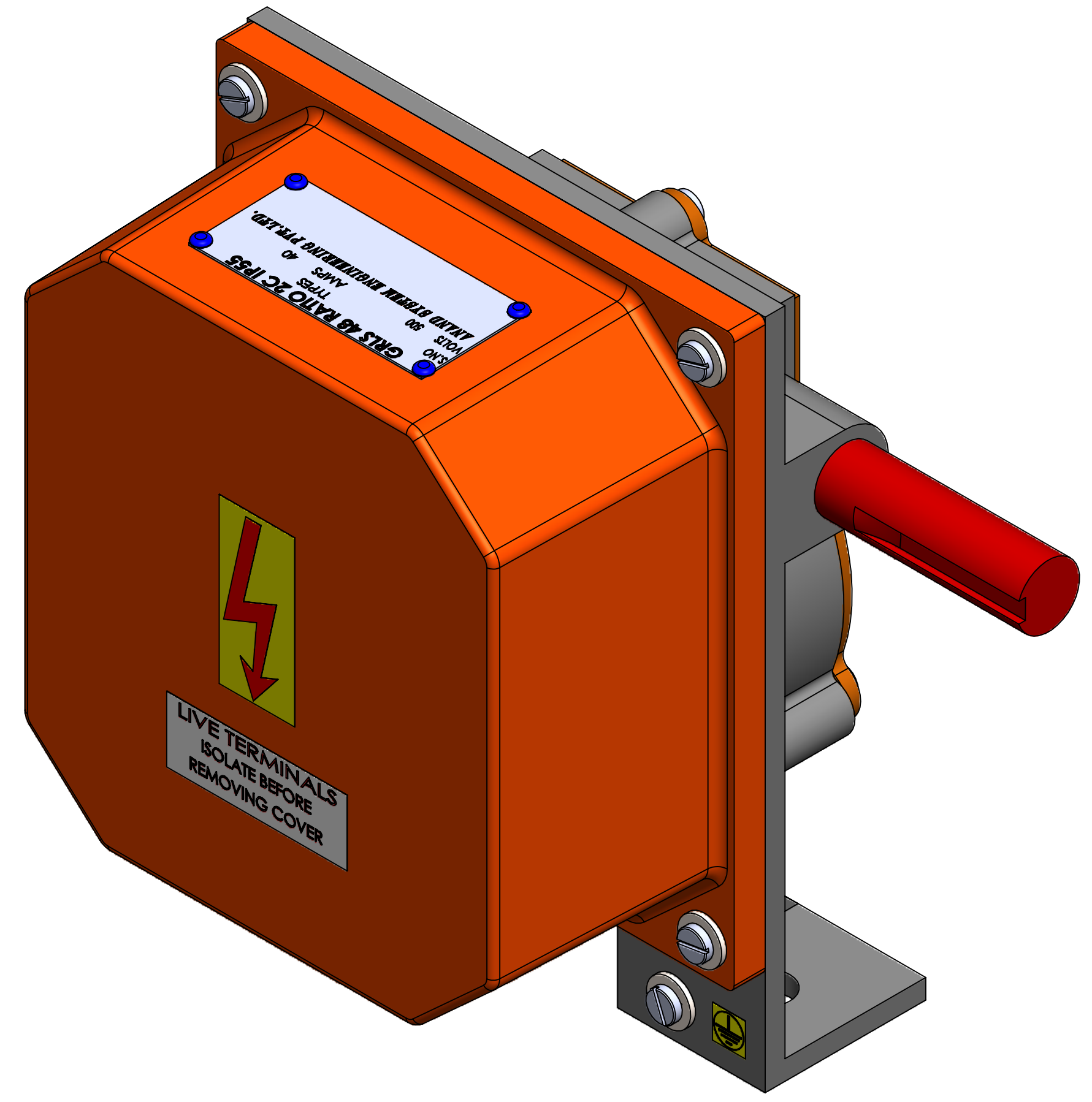
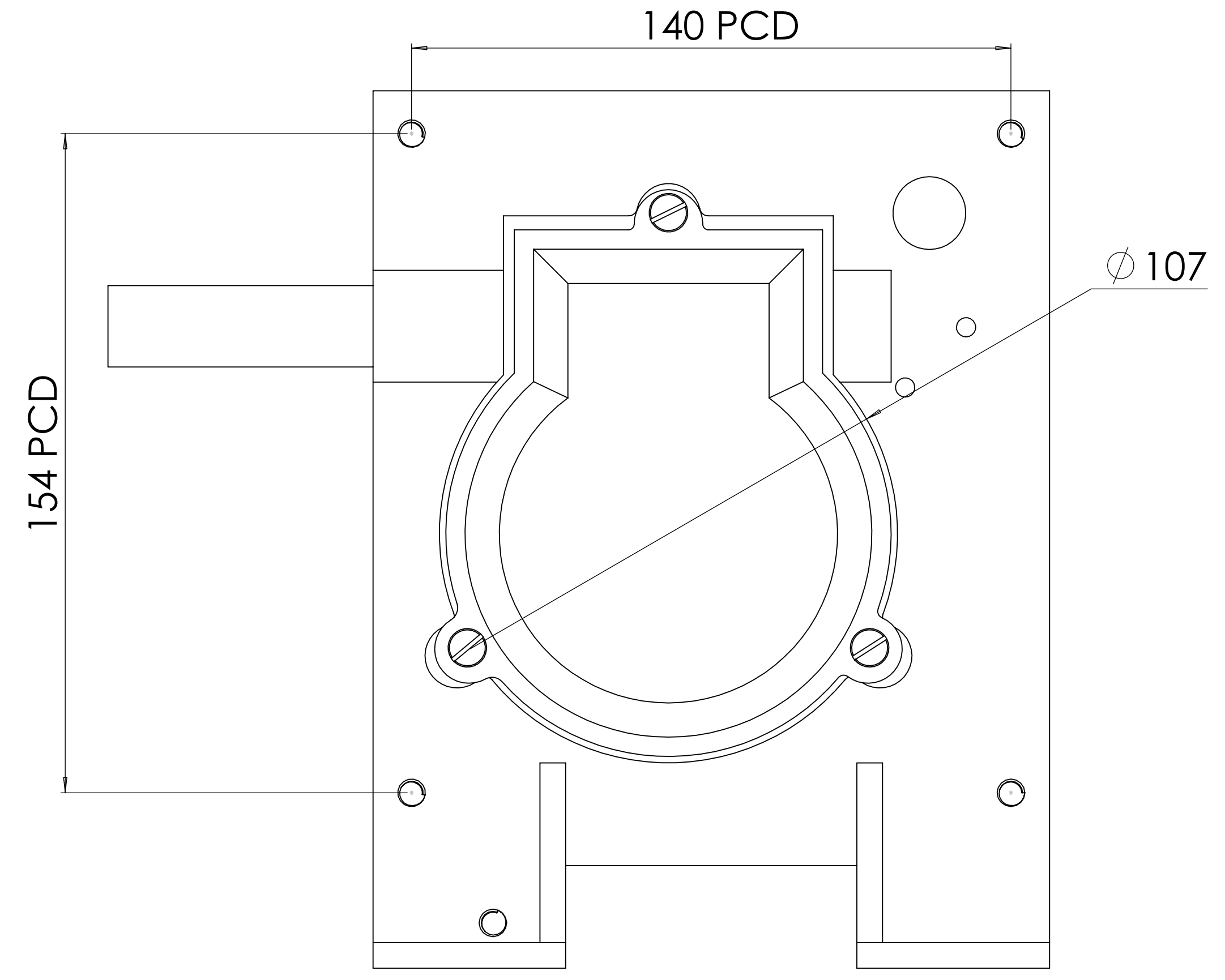

COMPANY NAME		DO NOT SCALE DRAWING		REVISION	
 ANAND SYSTEM ENGINEERING PVT LTD		TITLE:		GRLS 48 RATIO 2C IP55 2D	
		DWC NO.		SIGNATURE	
Email id: info@anancontrol.in		DATE		A1	
CONTACT NO: 9137620579		SCALE: 1:2		SHEET 1 OF 2	
DRAWN	CHK'D	APP'VD	G.A.	MATERIAL:	WEIGHT:

EXPLODED VIEW

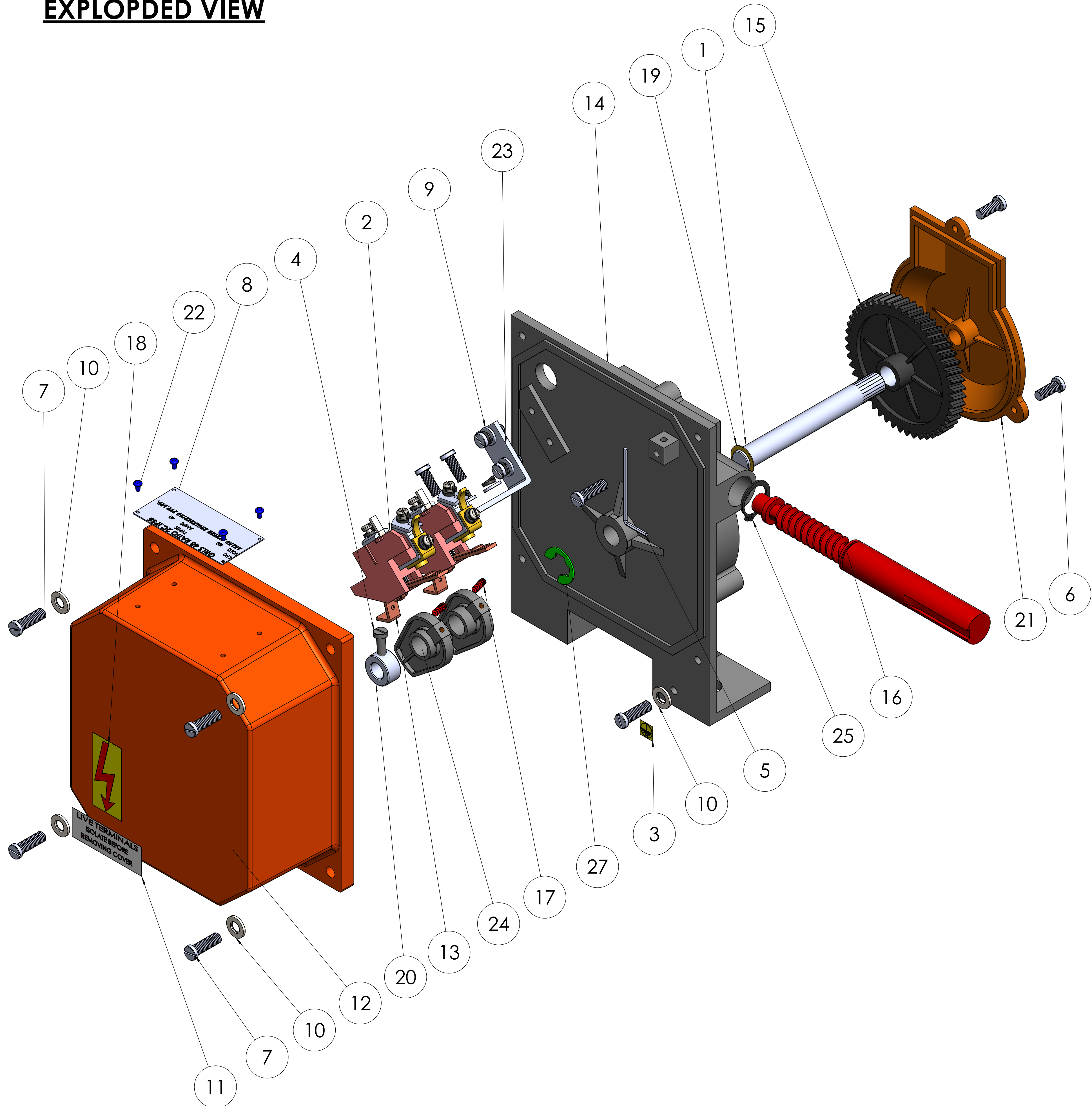

ITEM NO.	PART NAME	DESCRIPTION	Material	QTY.
1	GEAR SHAFT	110X12.7	M.S.	1
2	CONTACT BLOCK	CONTACT BLOCK ASSEMBLY IP-4140AMP	-	2
3	ERTHING STICKER (GRLS 2C IP55)	ERTHING STICKER	-	1
4	SCREW	5X15	M.S.	1
5	M2 ALLENKEY	CAM FIXING	M.S.	1
6	SCREW	CHEESED M6 6X15	M.S.	7
7	SCREW	CHEESED M6 6X20	M.S.	6
8	NAME PLATE	71X33X0.5 (4 HOLES 2MM)	ALUMINIUM	1
9	PLAIN WASHER	11X5.5X1.5	M.S.	4
10	PLAIN WASHER	11X5X1.5	M.S.	5
11	TERMINAL STICKER(GRLS 2C IP55)	TERMINAL STICKER	-	1
12	TOP COVER	174X158X76	ALUMINIUM DIE CAST	1
13	CONTACT STRIP	CONTACT BREAK STRIP	BRASS	2
14	BOTTOM COVER	205X158X46	ALUMINIUM DIE CAST	1
15	GEARS WARM WHEEL	48:1 , 86.5X12.7	N6	1
16	WARM SHAFT	19X175	M.S.	1
17	ALLENKEY SCREW	4X12	M.S.	2
18	ARROW STICKER	ARROW STICKER	-	1
19	BRASS WASHER	18X13X0.5	BRASS	1
20	BUSH	19X10X1/2" CAM FIXING	M.S.	1
21	GEAR BOX COVER	∅ 104, 123X73	N6	1
22	RIVET AB4	NAME PLATE RIVET	ALUMINIUM	4
23	L-BRAKET	BRACKET CONTACT FIXING	M.S.	1
24	MOLDED CAM	∅ 12.7	PLASTIC	2
25	RING TYPE CIRCLIP	∅ 17 GEAR WORM SHAFT	STAINLESS STEEL	1
26	SPRING WASHER	A5	SPRING STEEL	4
27	E CIRCLIP	11.5 GEAR SHAFT	CARBON STEEL	1

COMPANY NAME: **ANAND SYSTEM ENGINEERING PVT LTD**

DO NOT SCALE DRAWING

TITLE: **GRLS 48 RATIO 2C IP55 2D**

REVISION:

EMAIL ID: info@anandcontrol.in

CONTACT NO: [9137620579](tel:9137620579)

DATE: _____ SIGNATURE: _____

SCALE: 1:1 SHEET 2 OF 2