

# EXPLODED VIEW

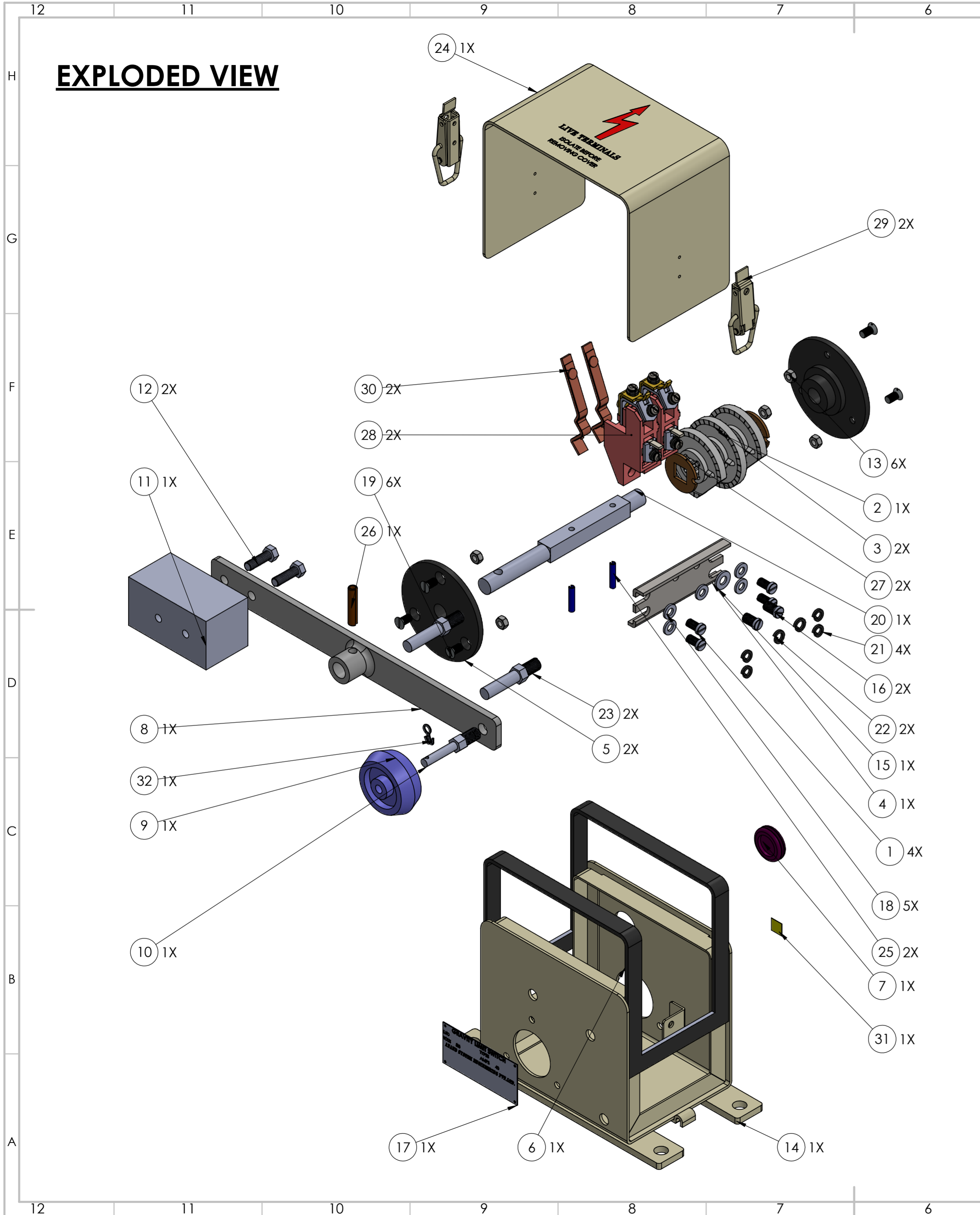

ITEM NO.	PART NUMBER	DESCRIPTION	MATERIAL	QTY.
1	BUFFELE SCREW 5X10	CHEESED 5X10	M.S.	4
2	CAM	SPARE CAM	NYLON	1
3	CAM	CAM1	NYLON	2
4	CONTACT STRIP	CONTACT FIXING STRIP	M.S	1
5	END BUSH	END BUSH 74MM OD	NYLON	2
6	GASKET PATTI	BODY FIXING	RUBBER	1
7	GRUMET	GRUMET 3/4"	RUBBER	1
8	HANDLE	MS HANDLE	M.S.	1
9	HANDLE ROLLER	HANDLE ROLLER 30X47	NYLON	1
10	PIN	HANDLE ROLLER PIN 6X9X50	M.S	1
11	HANDLE WEGHT	SQ 40X40X72	M.S.	1
12	BOLT	HANDLE WEIGHT BOLT 6X20	ALUMINIUM	2
13	HEX NUT	M5	M.S.	6
14	HOUSING	HOUSING LEVER LIMIT SWITCH	M.S.	1
15	PLAIN WASHER	WASHER 13X6.5X1.5	M.S.	1
16	SCREW	CHEESED M6 SCREW	M.S.	2
17	NAME PLATE	71X33X0.5 (4 HOLES 2MM)	ALUMINIUM	1
18	PLAIN WASHER	11X5.5X1.5	M.S.	5
19	SCREW CSK	END BUSH 5X10 CSK	M.S.	6
20	SHAFT	SQ SHAFT 12X147X MIDDLE 77MM	M.S.	1
21	SPRING WASHER	WASHER A5	M.S.	4
22	SPRING WASHER	WASHER A6	M.S.	2
23	STOPPER PIN	HEX ROD 11X50 M8	M.S.	2
24	TOP COVER	HOUSING TOP COVER	M.S.	1
25	TUBLER PIN	4X20 SHAFT FIXING PIN	STEEL	2
26	TUBLER PIN	6X30 HANDLE FIXING PIN	STEEL	1
27	LOCK WASHER	LOCK WASHER 12X12 SQ 29X1.5 MM	M.S.	2
28	CONTACT BLOCK	CONTACT BLOCK ASSEMBLO 40AMP		2
29	LOCK	HOUSING LOCK	M.S.	2
30	CONTACT STRIP	CONTACT BREAK STRIP	BRASS	2
31	ERTHING STICKER	ERTHING LEVEL		1
32	cotter pin	HANDLE ROLLER FIXING 2MM X 1/2" 1/16 X 3/4	M.S.	1

COMPANY NAME: **ANAND SYSTEM ENGINEERING PVT LTD**

DO NOT SCALE DRAWING

REVISION

TITLE: **GA GRAVITY LIMIT SWITCH 1WAY 2C IP41 ASSEMBLY**

Email id: info@anandcontrol.in

CONTACT NO: 9137620579

DWG NO.

A2

SCALE:1:5

SHEET 1 OF 2

FRONT VIEW

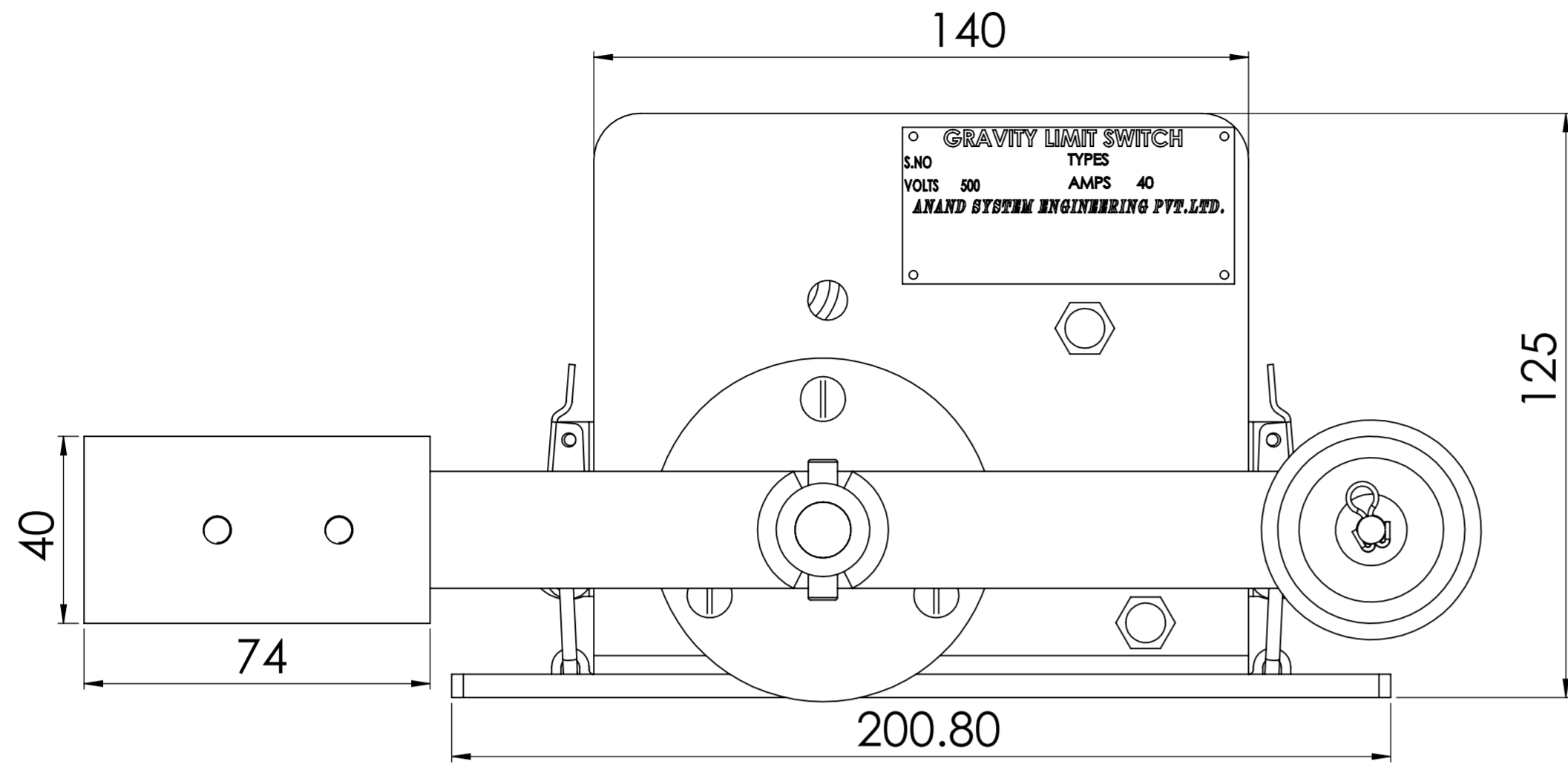

SIDE VIEW

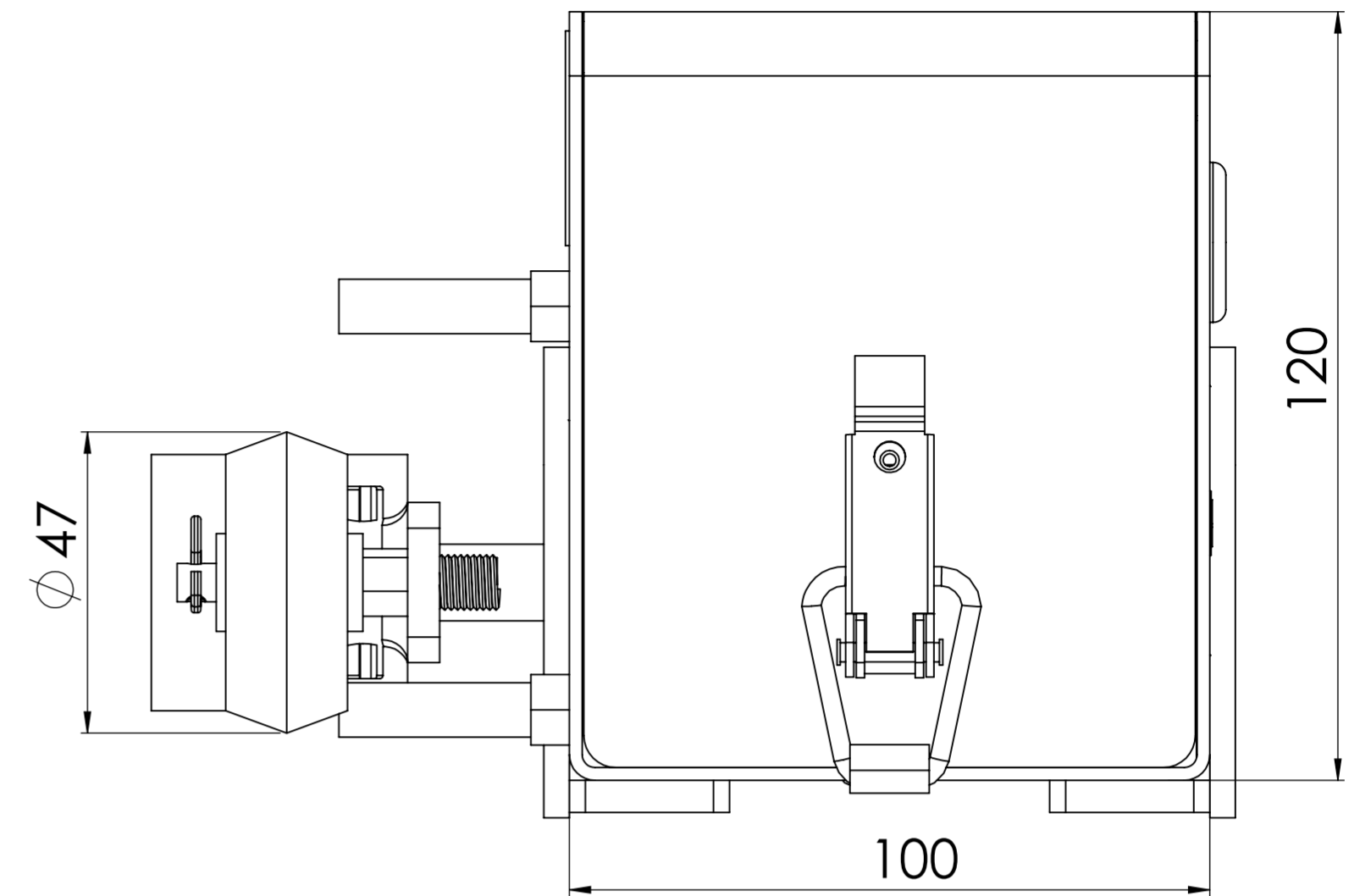

TOP VIEW

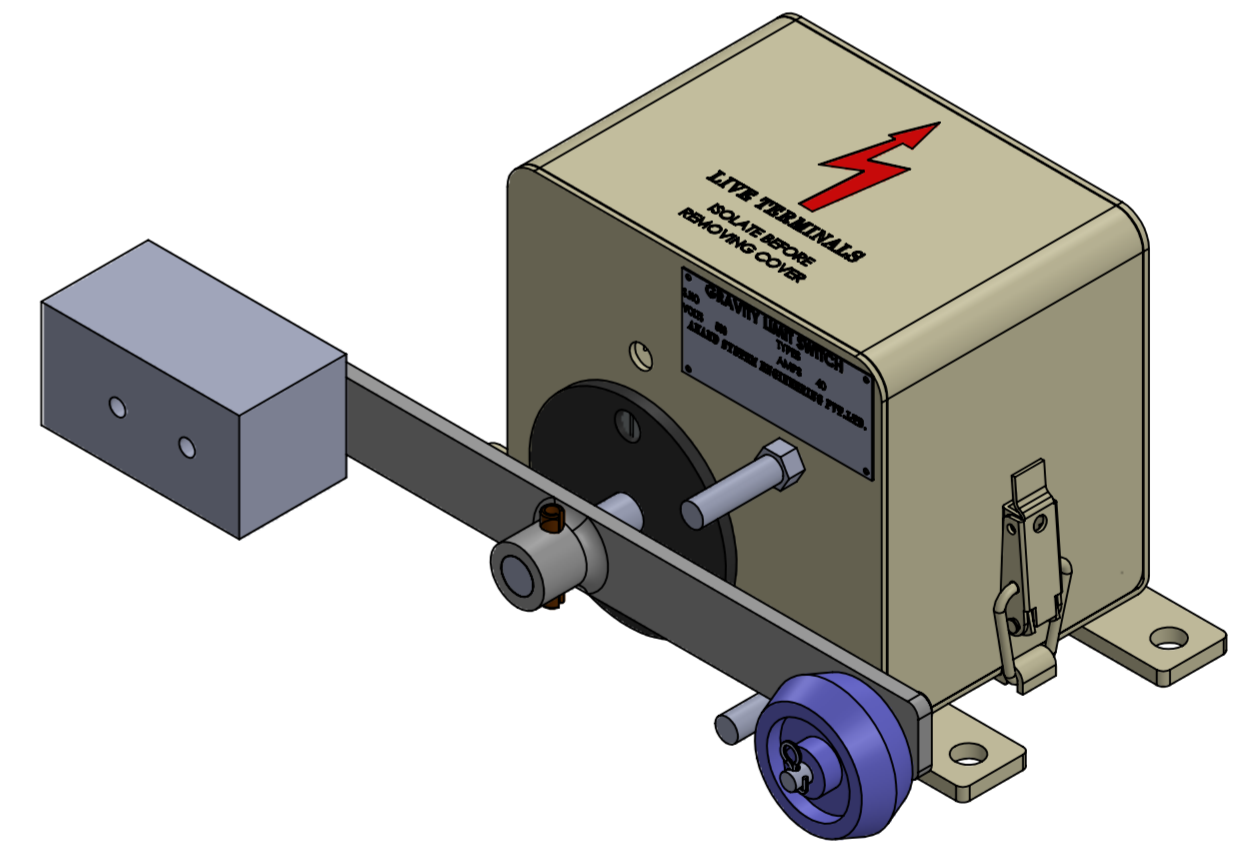
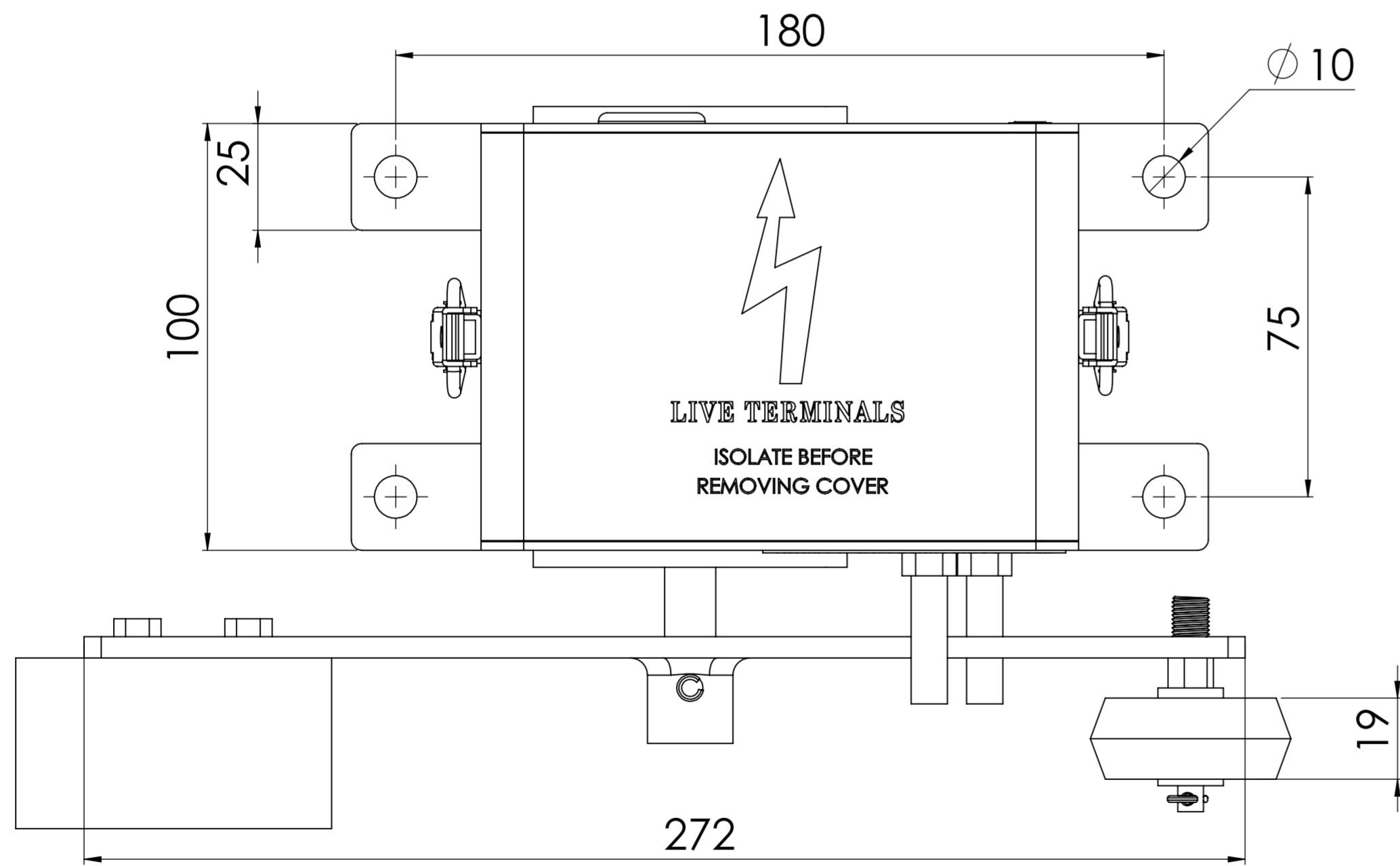

COMPANY NAME:		DO NOT SCALE DRAWING		REVISION	
 <b>ANAND SYSTEM ENGINEERING PVT LTD</b>		TITLE:			
		GA GRAVITY LIMIT SWITCH 1 WAY 2C IP41 ASSEMBLY. 2D			
Email id:info@anandcontrol.in		DWG NO.		A2	
CONTACT NO:9137620579		SCALE:1:5		SHEET 2 OF 2	