

EXPLODED VIEW

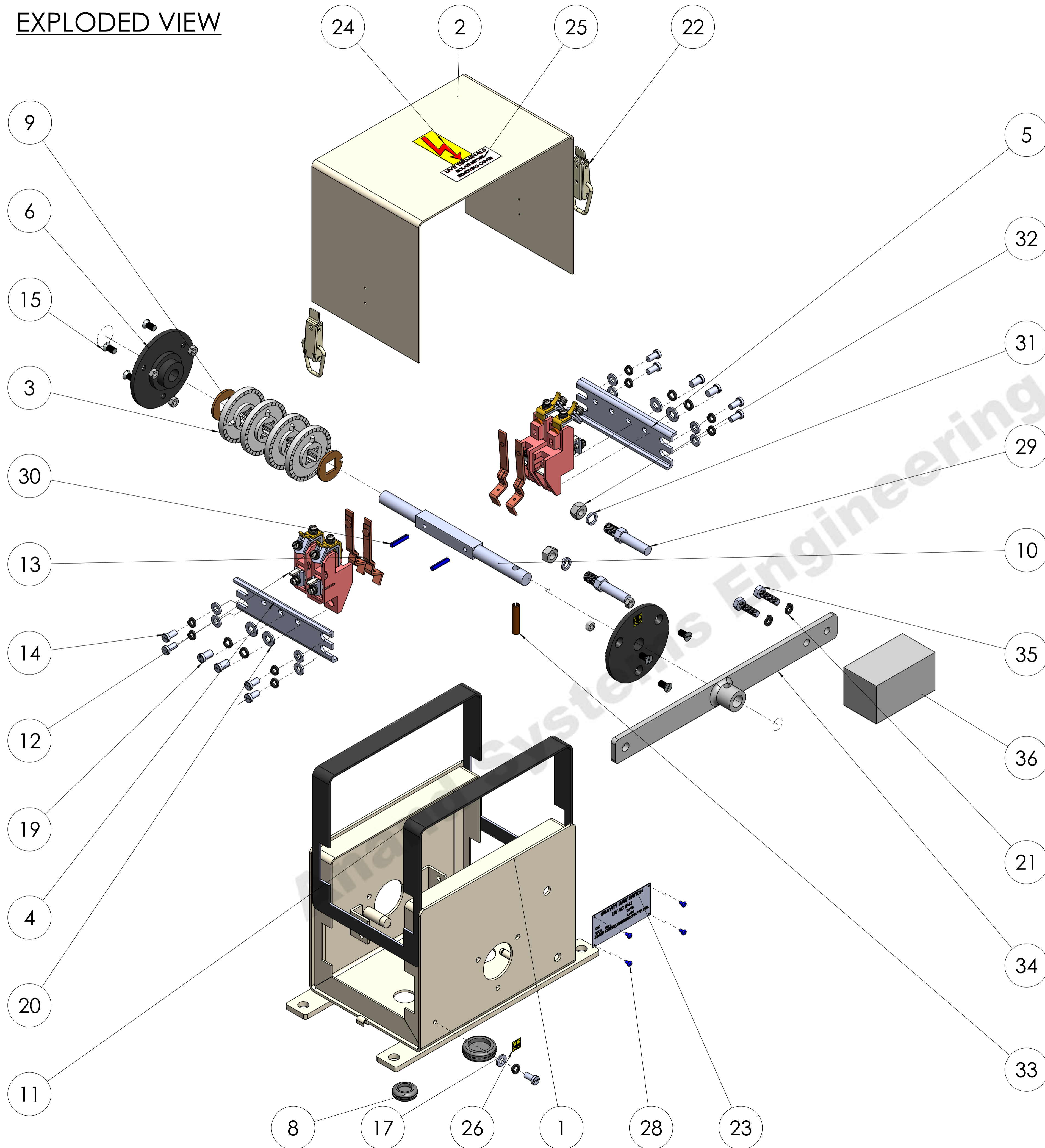
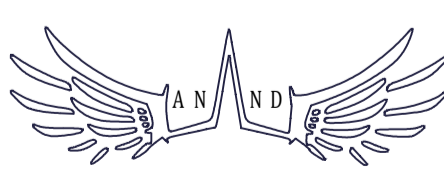

ITEM NO.	PART NAME	DESCRIPTION	MATERIAL	QTY.
1	HOUSING	HOUSING IP-41 4 CM	SHEET METAL	1
2	TOP COVER	HOUSING TOP COVER IP-41 4 CM	SHEET METAL	1
3	CAM	Ø 51X5.5	NYLON	4
4	CONTACT STRIP	LEFT SIDE CONTACT FIXING STRIP 3 HOLES	M.S.	1
5	CONTACT STRIP	RIDE SIDE CONTACT FIXING STRIP 4 HOLES	M.S.	1
6	END BUSH	NYLON END BUSH	NYLON	2
7	GRUMET	GRUMET 1"	RUBBER	1
8	GRUMET	GRUMET 3/4"	RUBBER	1
9	LOCK WASHER	12X12 SQ 29X1.5MM	M.S.	2
10	SHAFT	SQUARE SHAFT 12X12X147	M.S.	1
11	GASKET PATTI	BODY FIXING	RUBBER	1
12	CONTACT BLOCK	CONTACT BLOCK ASSEMBLY IP-41 40AMP	-	4
13	CONTACT STRIP	CONTACT BREAK STRIP	BRASS	4
14	CSK SCREW	CHEESED 5X10	M.S.	9
15	SCREW CSK	END BUSH 5X10 CSK	M.S.	6
16	HEX NUT	M5	M.S.	6
17	PLAIN WASHER	11X5.5X1.5	M.S.	9
18	SPRING WASHER	WASHER A5	SPRING STEEL	9
19	CHEESED SCREW	CHEESED SCREW M6X10	M.S.	4
20	PLAIN WASHER	13X6.5X1.5 PLAIN WASHER M6	M.S.	4
21	SPRING WASHER	WASHER A6	SPRING STEEL	6
22	LOCK	HOUSING LOCK	M.S.	2
23	NAME PLATE	71X 33X 0.5 (4 HOLE 2MM)	ALUMINIUM	1
24	ARROW STICKER	ARROW STICKER	PVC	1
25	TERMINAL STICKER	TERMINAL STICKER	PVC	1
26	ERTHING STICKER	ERTHING STICKER	PVC	1
27	STICKER	DOWN ARROW STICKER	PVC	1
28	RIVET AB4	NAME PLATE FIXING	ALUMINIUM	4
29	STOPPER PIN	HEX ROD 11X50, M8 THREAD	M.S.	2
30	TUBLER PIN	4X20 SHAFT FIXING TUBLER PIN	SPRING STEEL	2
31	SPRING WASHER M8	M8	SPRING STEEL	2
32	HEX NUT	M8	M.S.	2
33	TUBLER PIN	6X30 HANDLE FIXING TUBLER PIN	SPRING STEEL	1
34	HANDLE	MS HANDLE	M.S.	1
35	HEX BOLT	6X15, WAIGHT FIXING	M.S.	2
36	WEIGHT	SQ40X40X 72	M.S.	1

COMPANY NAME:		DO NOT SCALE DRAWING		REVISION:	
 ANAND SYSTEM ENGINEERING PVT LTD		TITLE: GRAVITY LIMIT SWITCH 1WAY 4C IP-41 2D		DATE: 20-12-2024	
				SIGNATURE:	
Email id: info@anandcontrol.in		FINISH:		DWG. NO.:	
CONTACT NO: 9137620579		SCALE:		SHEET: 1 OF 1	
DRWN: SAURABH	CKD:	APPR:	MFC:	MATERIAL:	WEIGHT:

FRONT VIEW

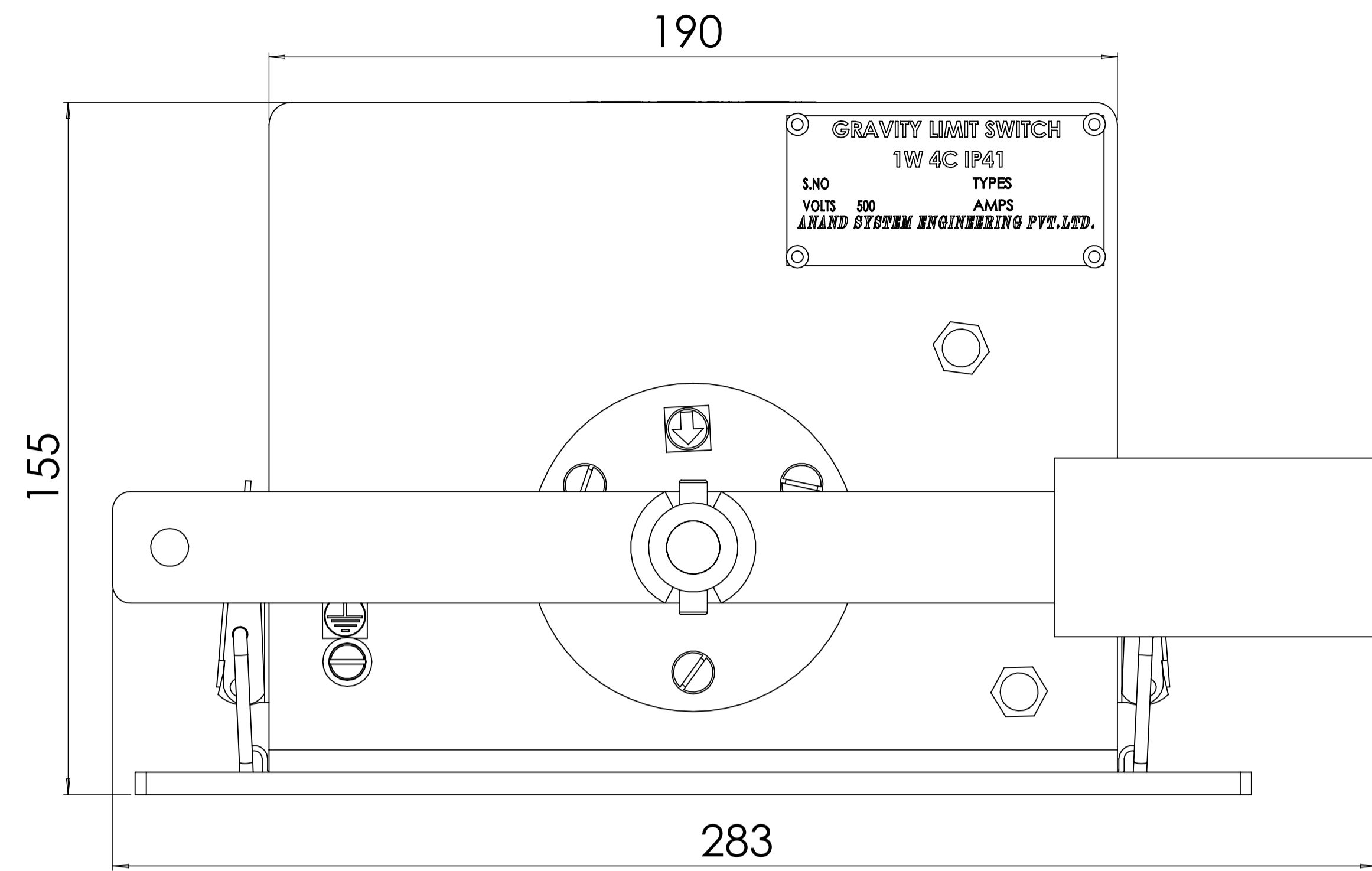

SIDE VIEW

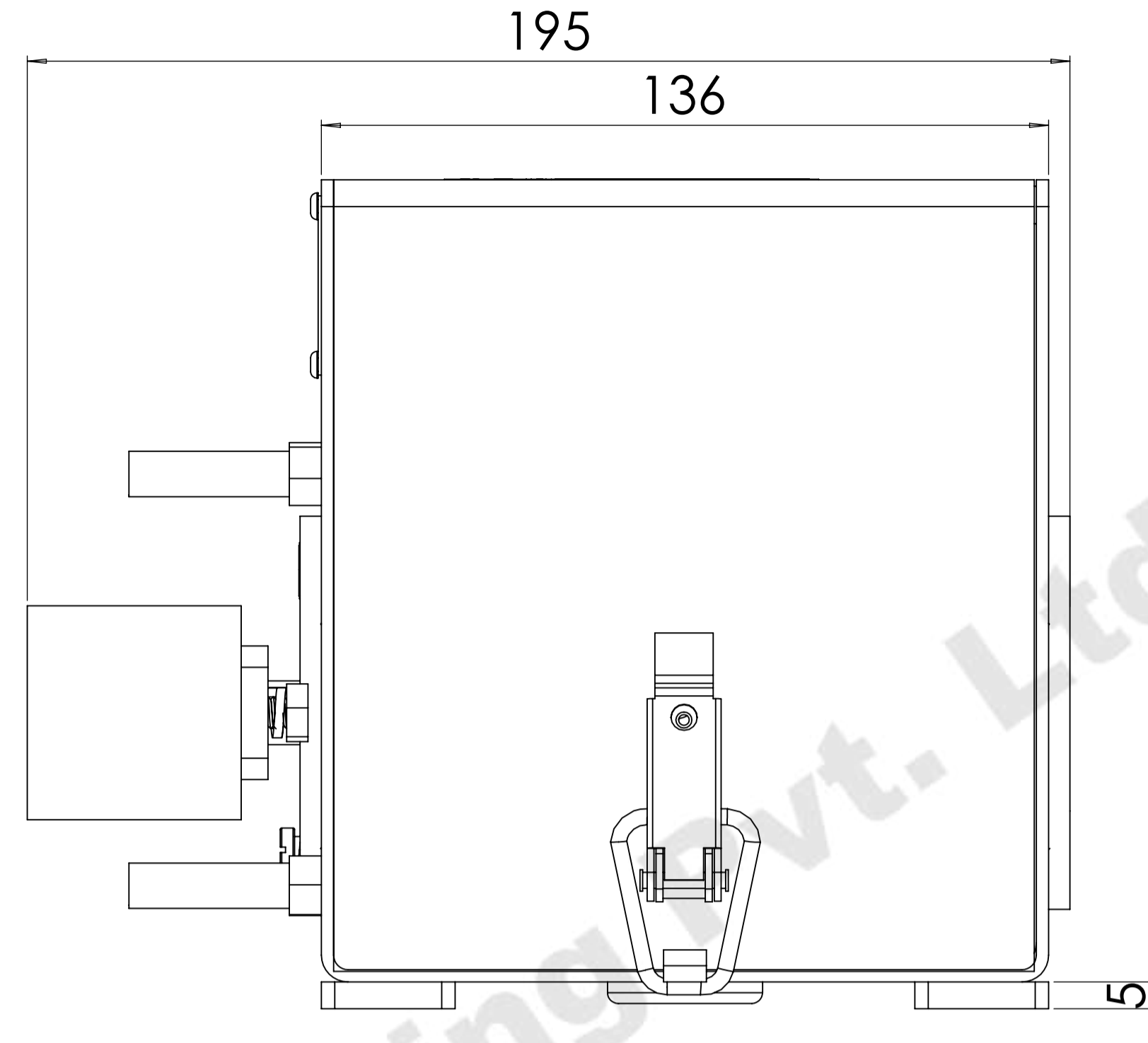

TOP VIEW

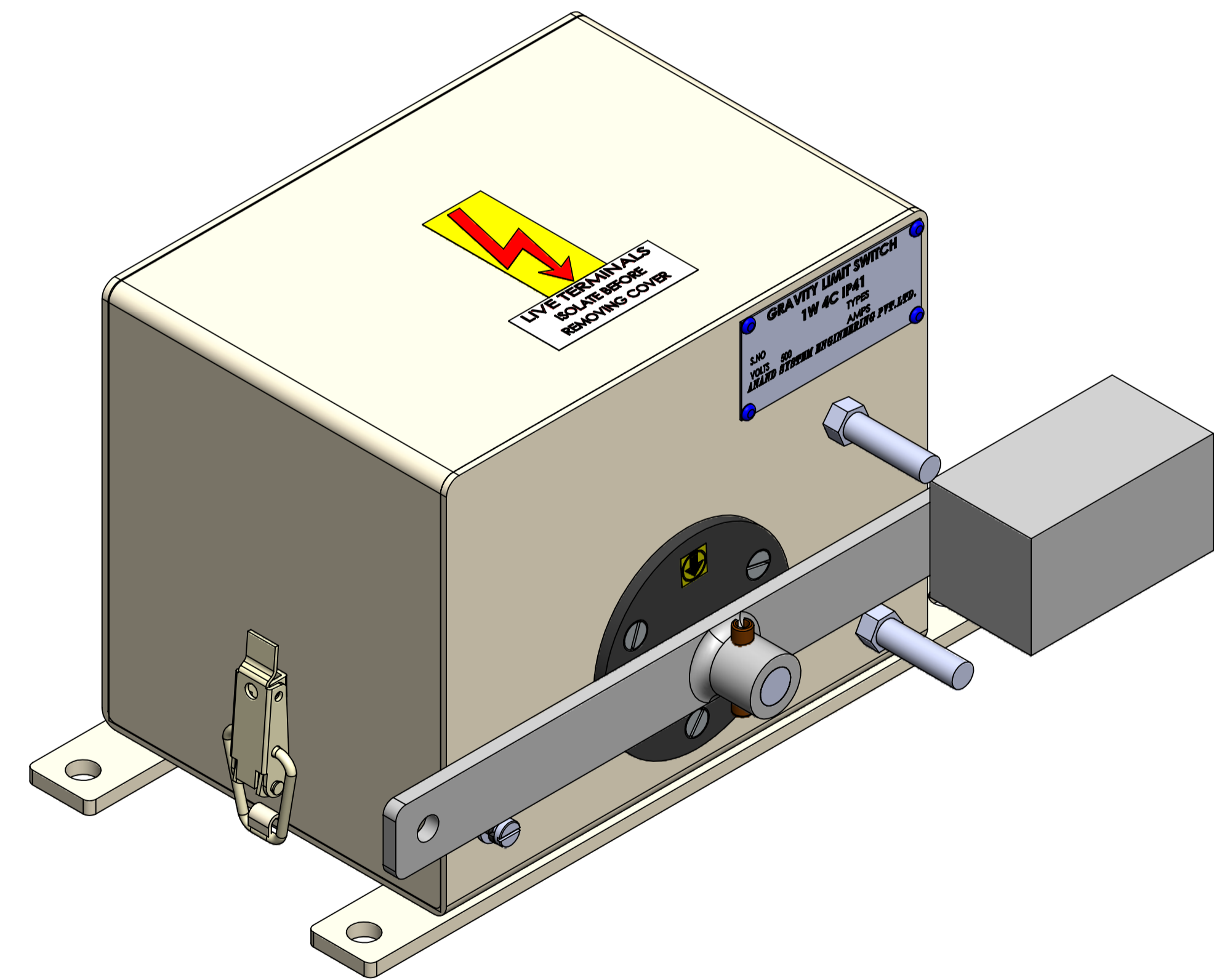
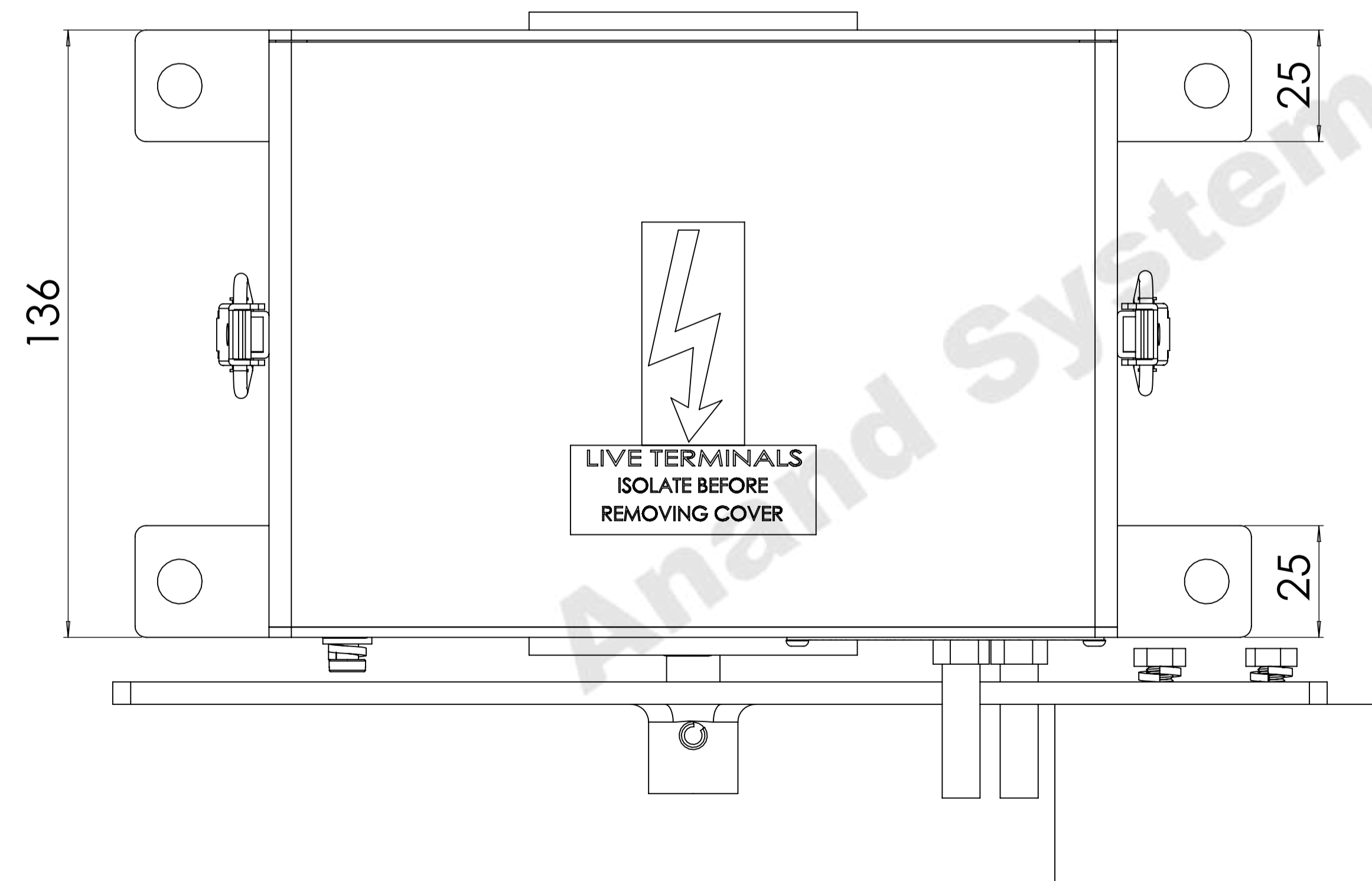

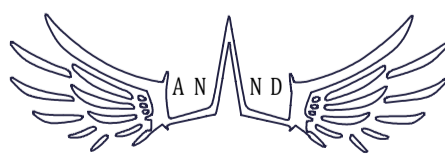
COMPANY NAME:		ANAND SYSTEM ENGINEERING PVT LTD		DO NOT SCALE DRAWING	REVISION:
		Email id: info@anandcontrol.in CONTACT NO: 9137620579		TITLE: GRAVITY LIMIT SWITCH 1WAY 4C IP-41 2D	
DATE: 20-12-2024	SIGNATURE:	DWG. NO.:		SHEET: 1 OF 1	
DRWN: SAURABH	CHECK:	APPRD:	MATERIAL:	SCALE:	A
WGT:	WEIGHT:				