

EXPLODED VIEW

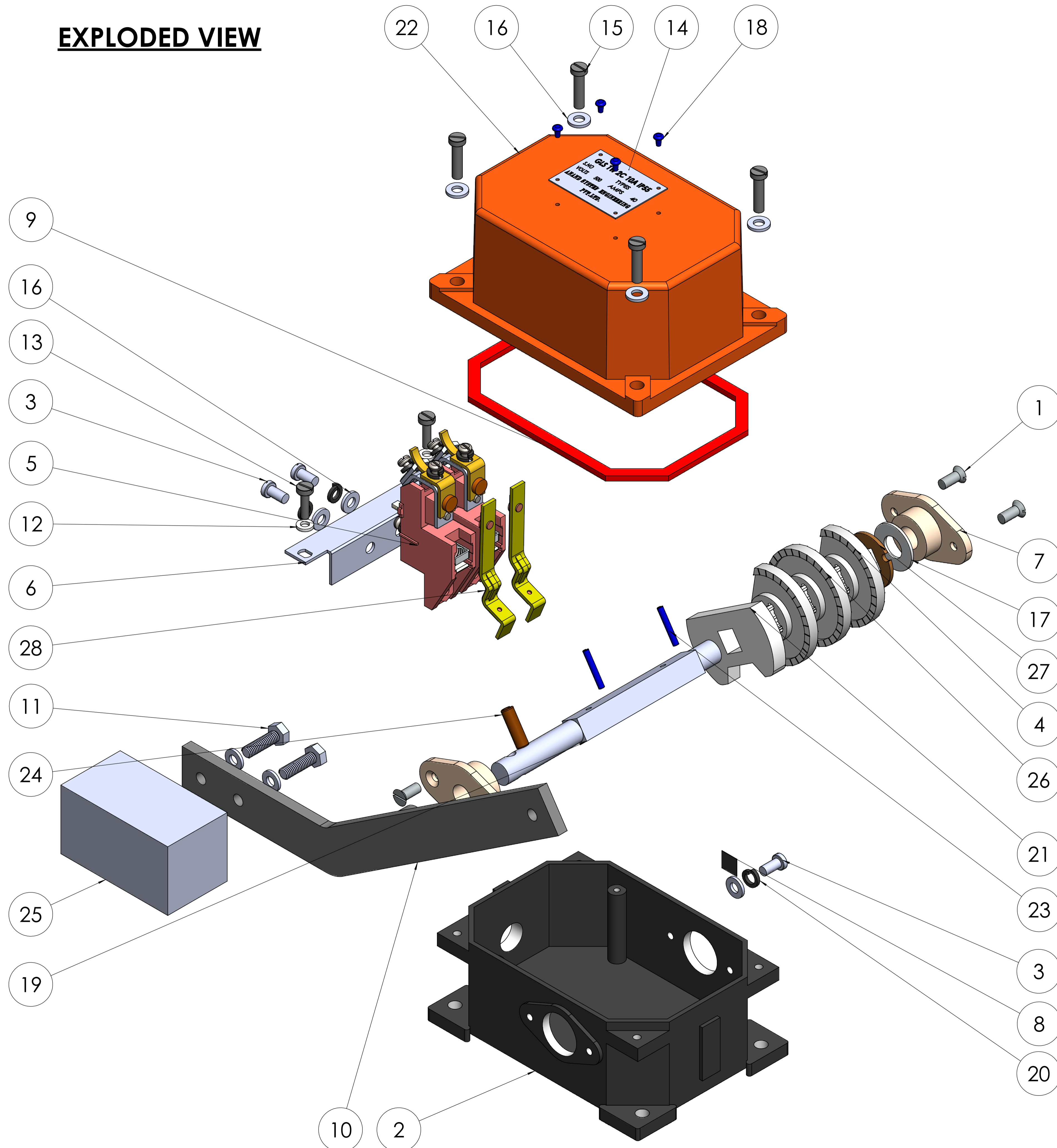

ITEM NO.	PART NUMBER	DESCRIPTION	Material	QTY.
1	SCREW CSK	END BUSH 5X10 (CSK)	M.S.	4
2	BOTTOM COVER	142x102x56	ALU DIE CAST	1
3	BUFFELE SCREW	CHEESED 5X10	M.S.	3
4	CAM	CAM 2	MELLAMINE	2
5	CONTACT BLOCK	CONTACT BLOCK ASSEMBLY	-	2
6	CONTACT STRIP	92X14X19	ALUMINIUM	1
7	END BUSH	57X33X12	NYLON	2
8	ERTHING STICKER	ERTHING LEVEL	-	1
9	GASKET	135X96 , 3 THK	RUBBER	1
10	HANDLE (GLS 1W 2C 40A IP55)	266x54x25	M.S.	1
11	HEX BOLT	6X15, WAIGHT FIXING	M.S.	2
12	PLAIN WASHER	M4 8.5X4.5X1.5	M.S.	2
13	SCREW	4X15 SLOTTED	M.S.	2
14	NAME PLATE	45X35X0.5(4 HOLES 2MM)	ALUMINIUM	1
15	HOUSING SCREW	5X15	M.S.	4
16	PLAIN WASHER	11X5.5X1.5	M.S.	9
17	PLAIN WASHER	25X13.5X1.5	M.S.	1
18	RIVET	NAME PLATE RIVET AB4	ALUMINIUM	4
19	SHAFT	SQ SHAFT 12X142X MIDDLE 80MM	M.S.	1
20	SPRING WASHER	WASHER M6	SPRING STEEL	3
21	STOPPER (GLS 1W 2C 40A IP55)	59X8X14	NYLON	1
22	TOP COVER	102X142X61	ALU DIE CAST	1
23	TUBLER PIN	4X20 SHAFT FIXING TUBLER PIN	SPRING STEEL	2
24	TUBLER PIN	6X30 HANDLE FIXING TUBLER PIN	SPRING STEEL	1
25	WEIGHT (GLS 1W 2C 40A IP55)	SQ40X40X 72	M.S.	1
26	CAM	SPARE CAM	NYLON	1
27	LOCK WASHER	LOCK WASHER 12X12 SQ 29X1.5MM	M.S.	1
28	CONTACT STRIP	CONTACT FIXING STRIPS	M.S.	2

COMPANY NAME: **ANAND SYSTEM ENGINEERING PVT LTD**

DO NOT SCALE DRAWING

TITLE: **GRAVITY LIMIT SWITCH 1W 2C IP55 ASSEMBLY 2D**

Email id: info@anandcontrol.in

CONTACT NO: [9137620579](tel:9137620579)

DATE: _____ SIGNATURE: _____

SCALE: 1:5 SHEET 1 OF 2

FRONT VIEW

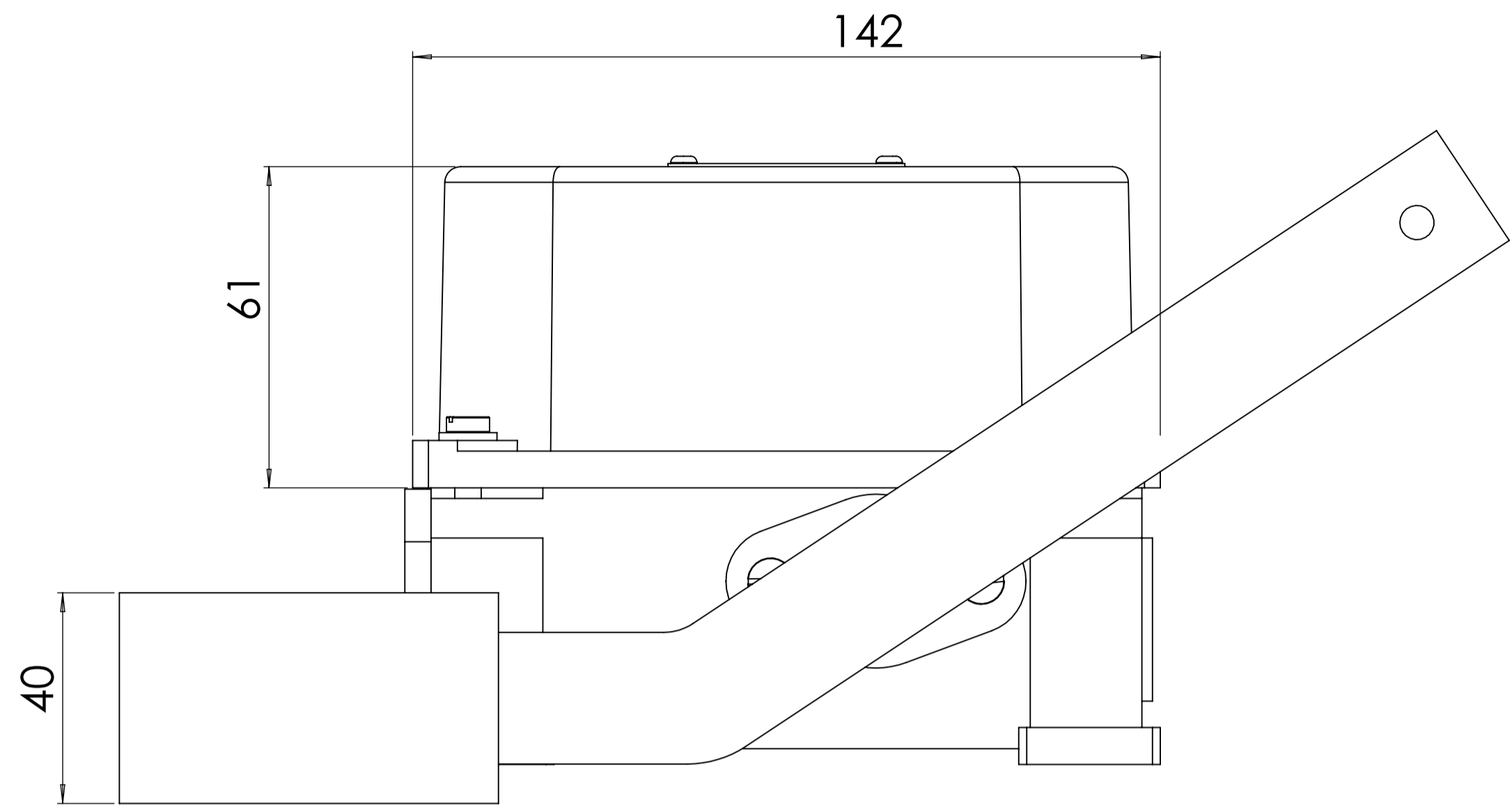

SIDE VIEW

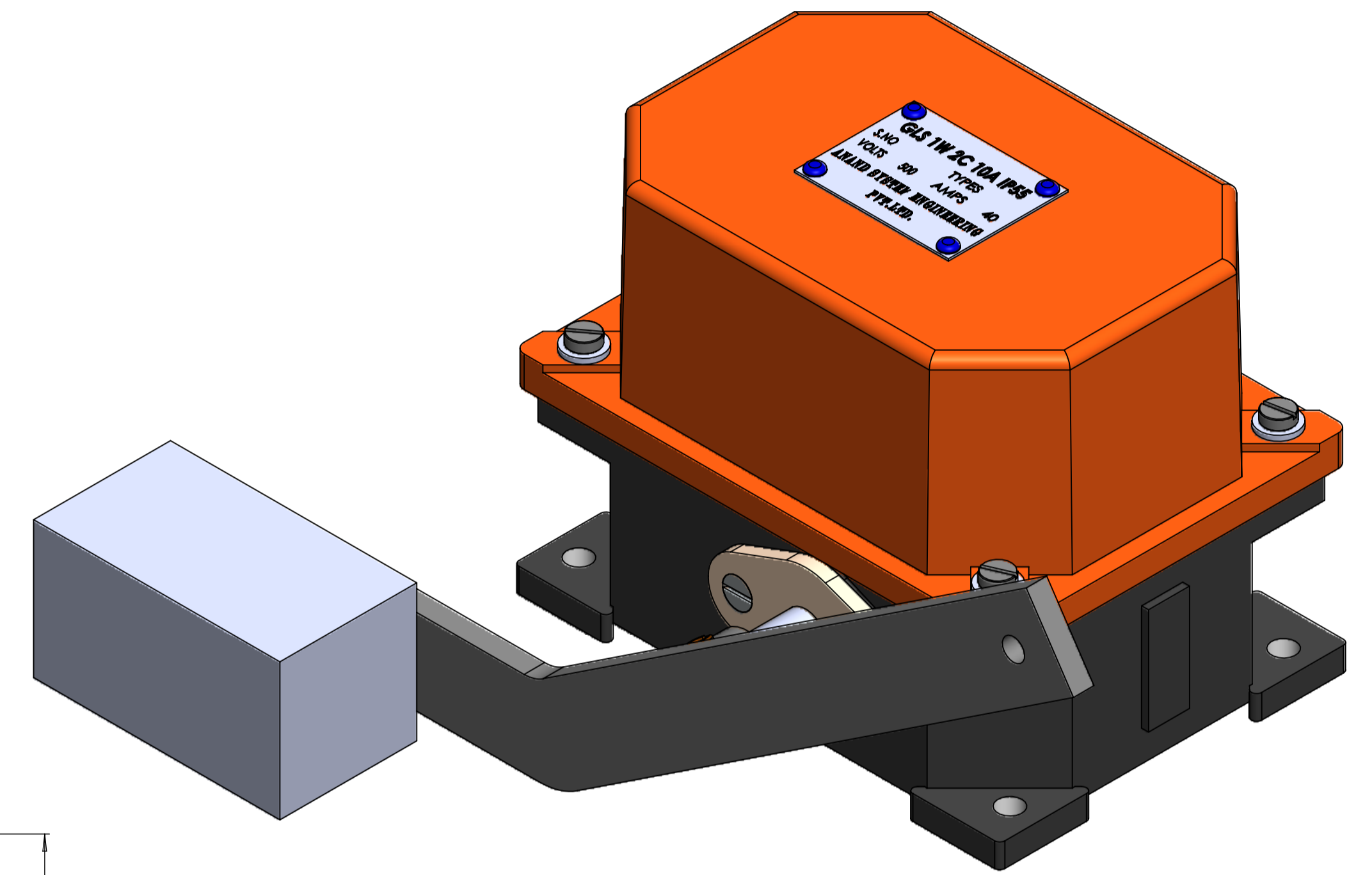
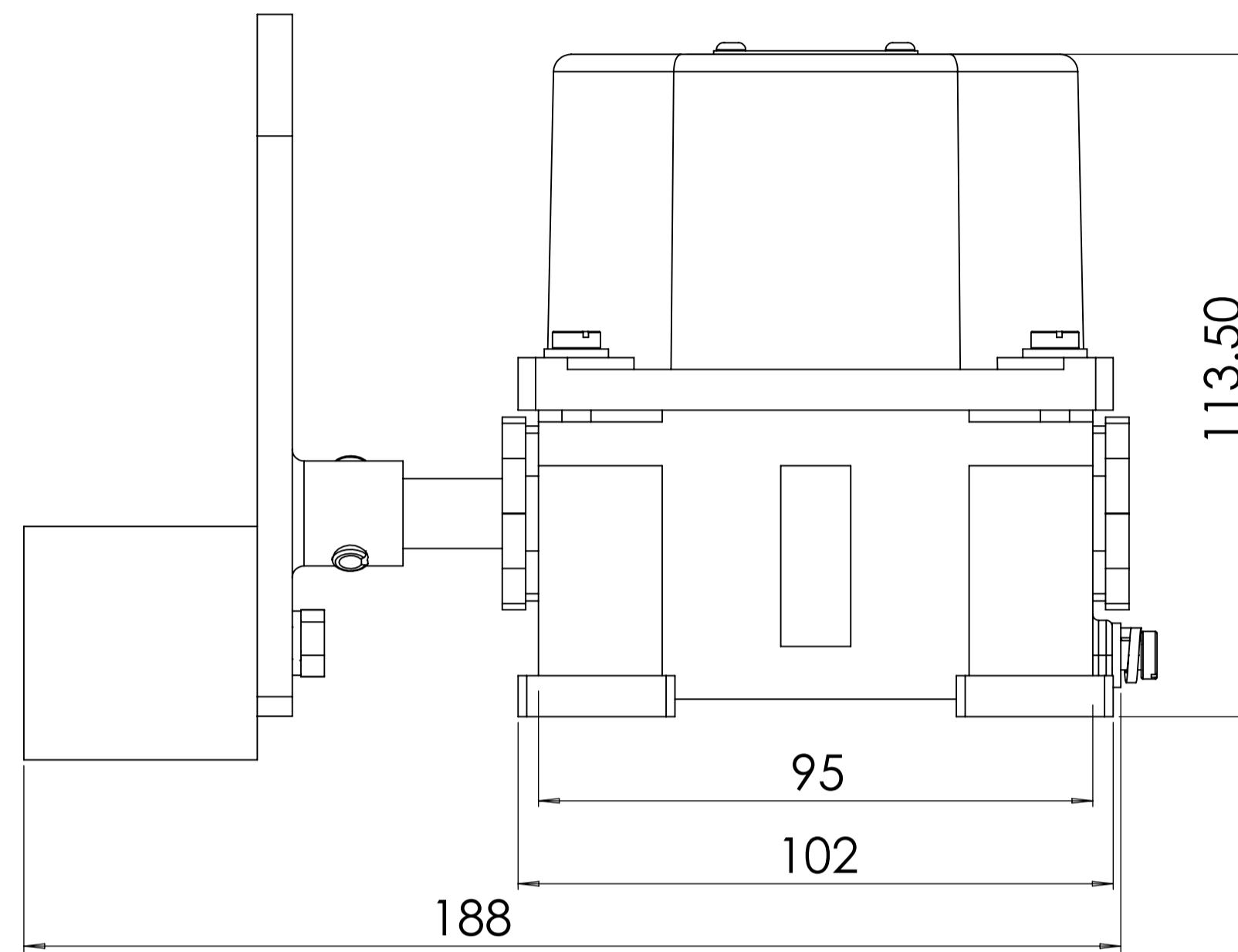

132
121 PCD

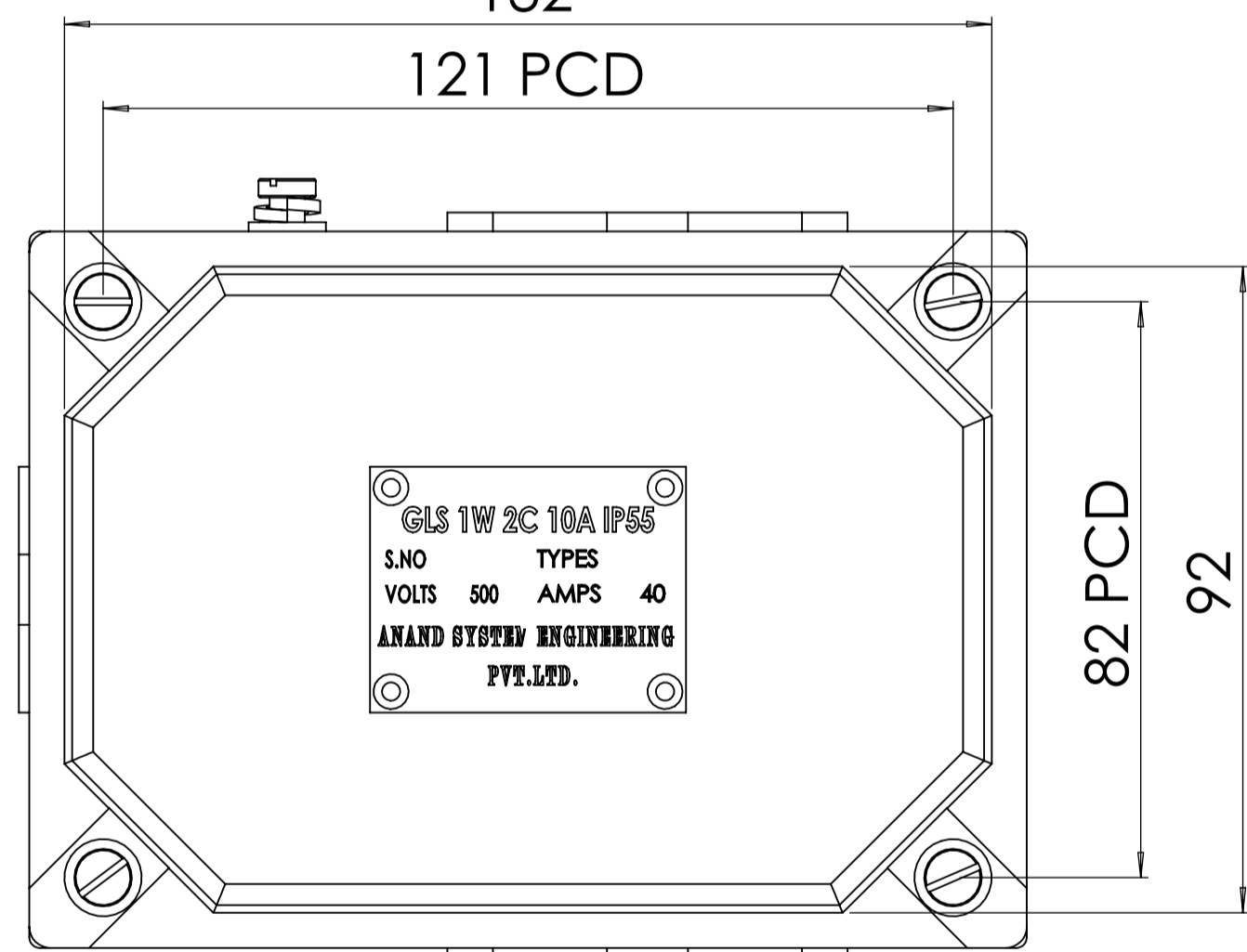

82 PCD
92

TOP VIEW

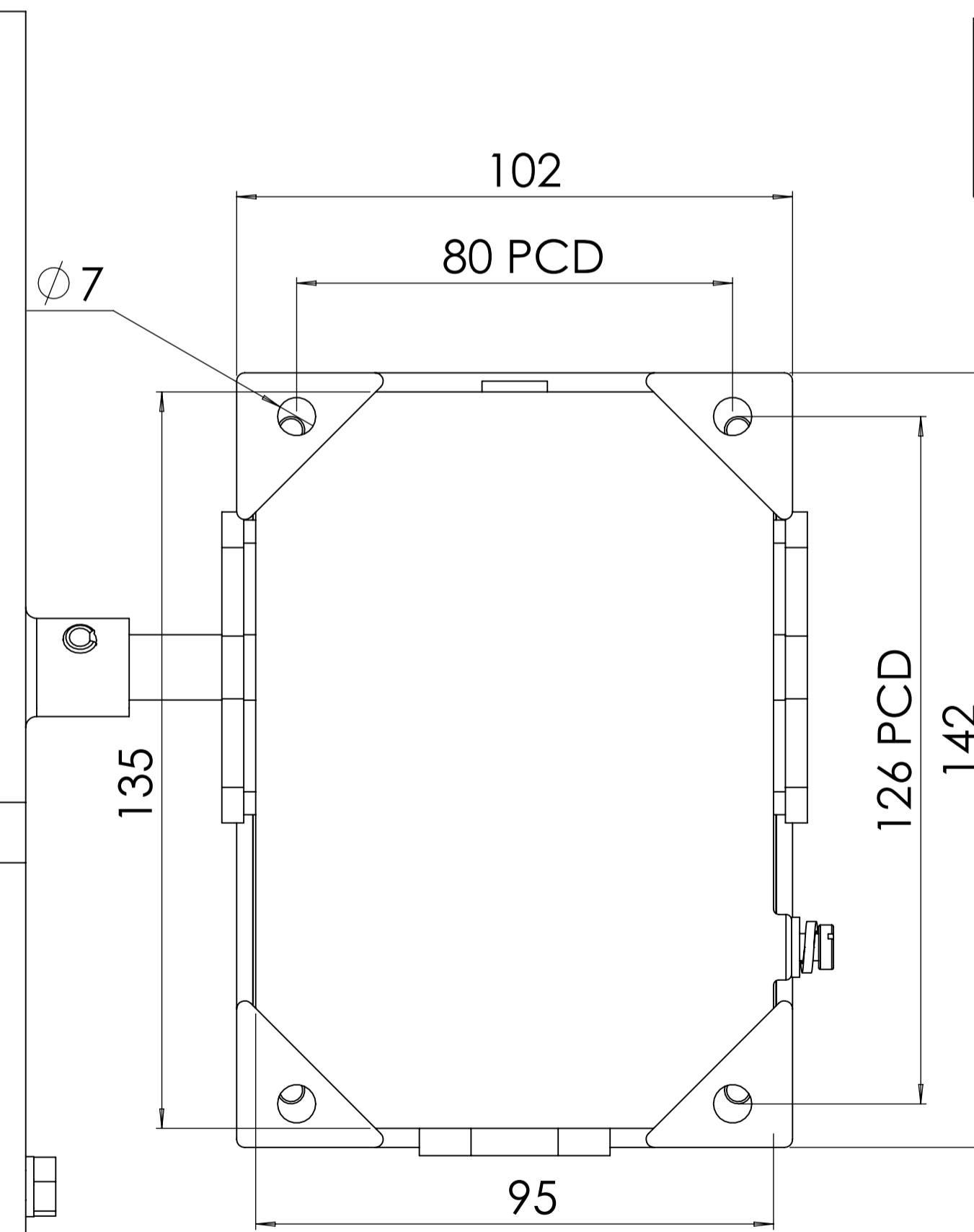
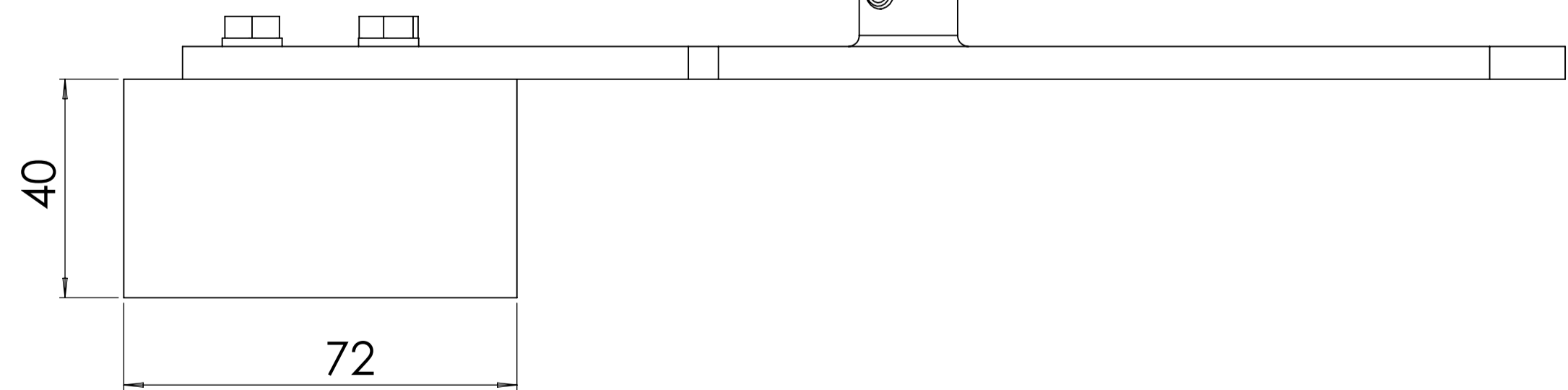

BOTTOM VIEW

COMPANY NAME:  ANAND SYSTEM ENGINEERING PVT LTD

Email id: info@anandcontrol.in

CONTACT NO: 9137620579

DO NOT SCALE DRAWING
REVISION
TITLE: GRAVITY LIMIT SWITCH 1W 2C IP55 ASSEMBLY 2D

DRAWN: _____
CHKD: _____
APPVD: _____
G.A: _____

MATERIAL: _____
WEIGHT: _____
SCALE: 1:15
SHEET 2 OF 2

A1