

# EXPLODED VIEW

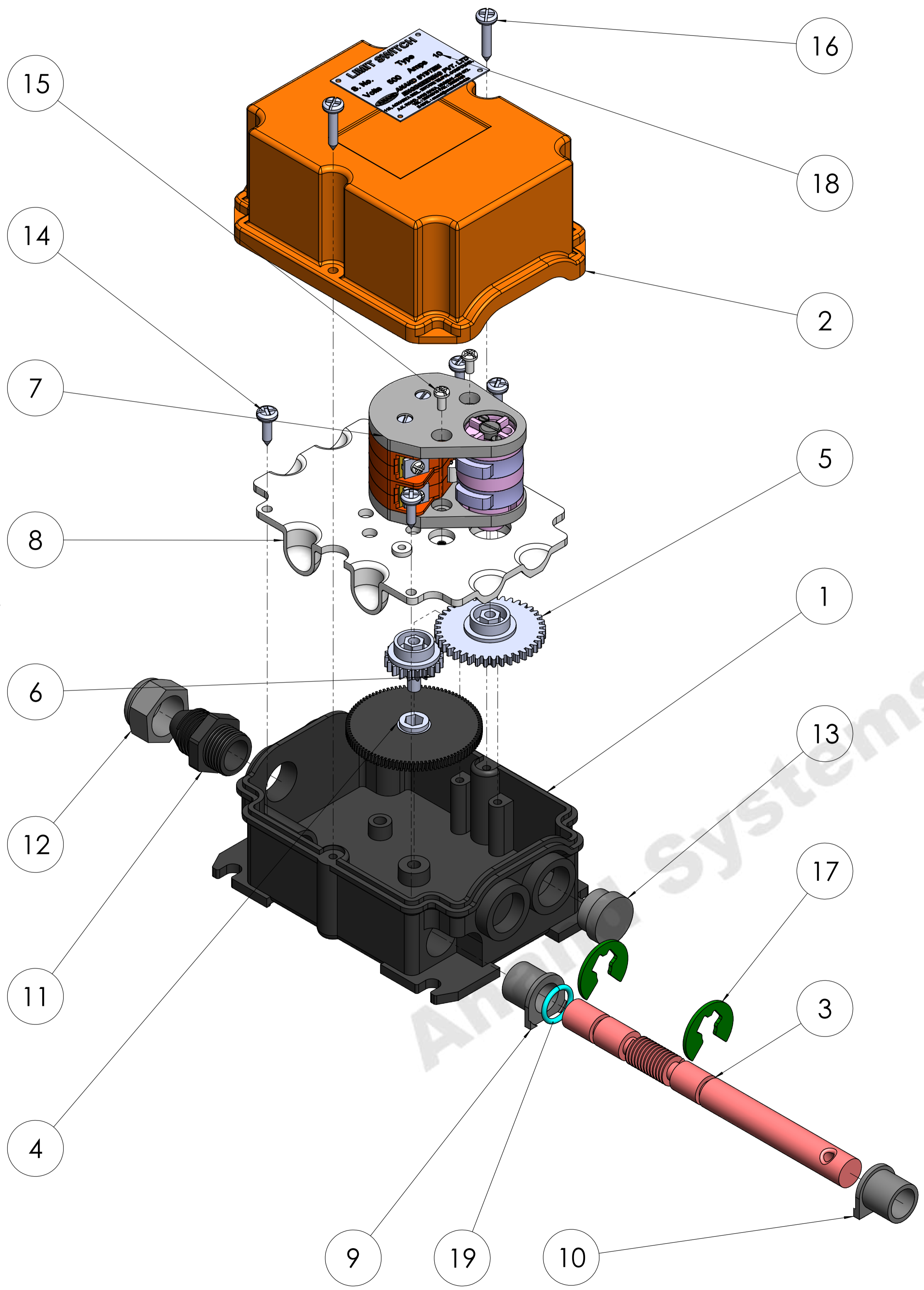

ITEM NO.	PART NAME	DESCRIPTION	Material	QTY.
1	BOTTOM COVER	126X91X45	THERMO PLASTIC	1
2	TOP COVER	122X92X50	THERMO PLASTIC	1
3	WORM SHAFT	143X Ø 12, SINGLE THREAD 14 TURN	M.S.	1
4	GEARS WARM WHEEL	Ø 51, 100 TEETH	THERMO PLASTIC	1
5	GEARS WARM WHEEL	Ø 41.5, 40TEETH	THERMO PLASTIC	1
6	TOP GEAR	Ø 22, 20TEETH	THERMO PLASTIC	1
7	FG CONTACT BLOCK ASSEMBLY (FG 200 P2)	47X30X7	THERMO PLASTIC	1
8	FG ASSEMBLY PLATE	109X82X3	THERMO PLASTIC	1
9	GEAR SHAFT BUSH CLOSE	15.5X Ø 16	THERMO PLASTIC	1
10	GEAR SHAFT BUSH OPEN	15X Ø 16	THERMO PLASTIC	1
11	CABLE GLAND	Ø 16.5X30	THERMO PLASTIC	1
12	CABLE GLAND NUT	HEX-21X15	THERMO PLASTIC	1
13	GRUMET CAP	Ø 20X 11	THERMO PLASTIC	1
14	SCREW	SELF THREADED 8X13	M.S.	4
15	STAR SCREW	M4X6.5	M.S.	2
16	SCREW	SELF THREADED 8X19	M.S.	2
17	E CIRCLIP 8mm	8X25	SPRING STEEL	2
18	NAME PLATE	47X37	ALUMINIUM	1
19	O RIPNG	12mm	RUBBER	1

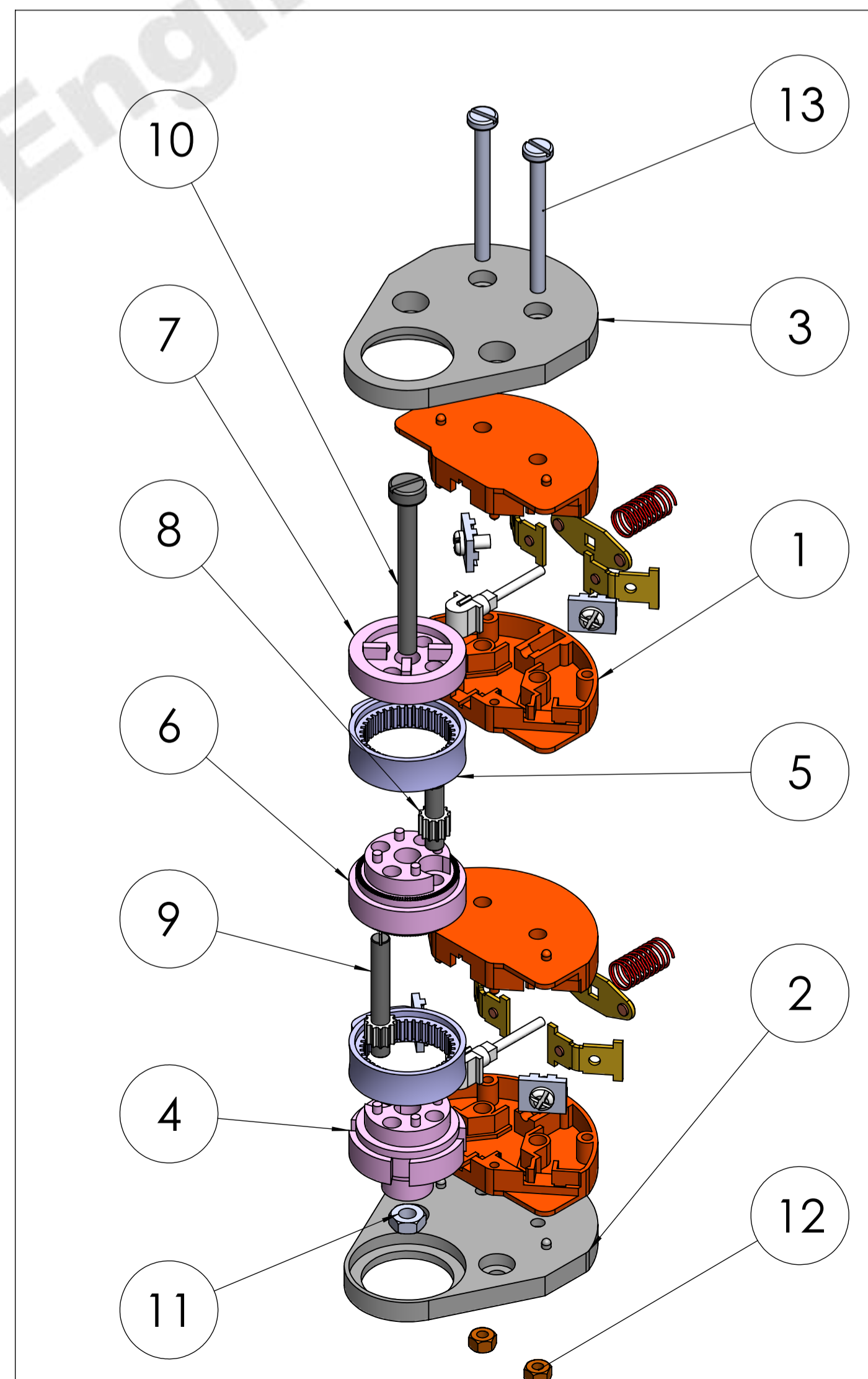

ITEM NO.	PART NAME	DESCRIPTION	Material	QTY.
1	CONTACT BLOCK ASSEMBLY	P1	THERMO PLASTIC	2
2	BASE GUIDE CAM PLATE	47X60X5	THERMO PLASTIC	1
3	TOP GUIDE CAM PLATE	47X60X5	THERMO PLASTIC	1
4	BASE CAM SET ASSEMBLY	Ø 25X20.5X ID- Ø 7	THERMO PLASTIC	1
5	GEAR RING CAM SET	Ø 25X Ø 19X8	THERMO PLASTIC	2
6	MIDDLE BASE CAM SET ASSEMBLY	Ø 25X15	THERMO PLASTIC	1
7	TOP CAM SET ASSEMBLY	Ø 25X7.5	THERMO PLASTIC	1
8	S.S.PIN	4X16	M.S.	1
9	S.S.PIN	4X30	M.S.	1
10	SCREW CHZ	4X40	M.S.	1
11	M4 NUT	Ø 4mm	M.S.	1
12	M3 NUT	Ø 3 mm	M.S.	2
13	M3 SCREW	3X35	M.S.	2

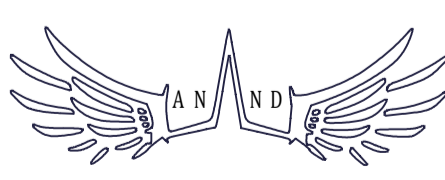
COMPANY NAME:  ANAND SYSTEM ENGINEERING PVT LTD

DO NOT SCALE DRAWING

TITLE: **FG 200 P2 ASEMBLY 2D**

EMAIL ID: info@anandcontrol.in

CONTACT NO: 9137620579

DATE: 27-11-2024

SHEET: 1 OF 1

TOP VIEW

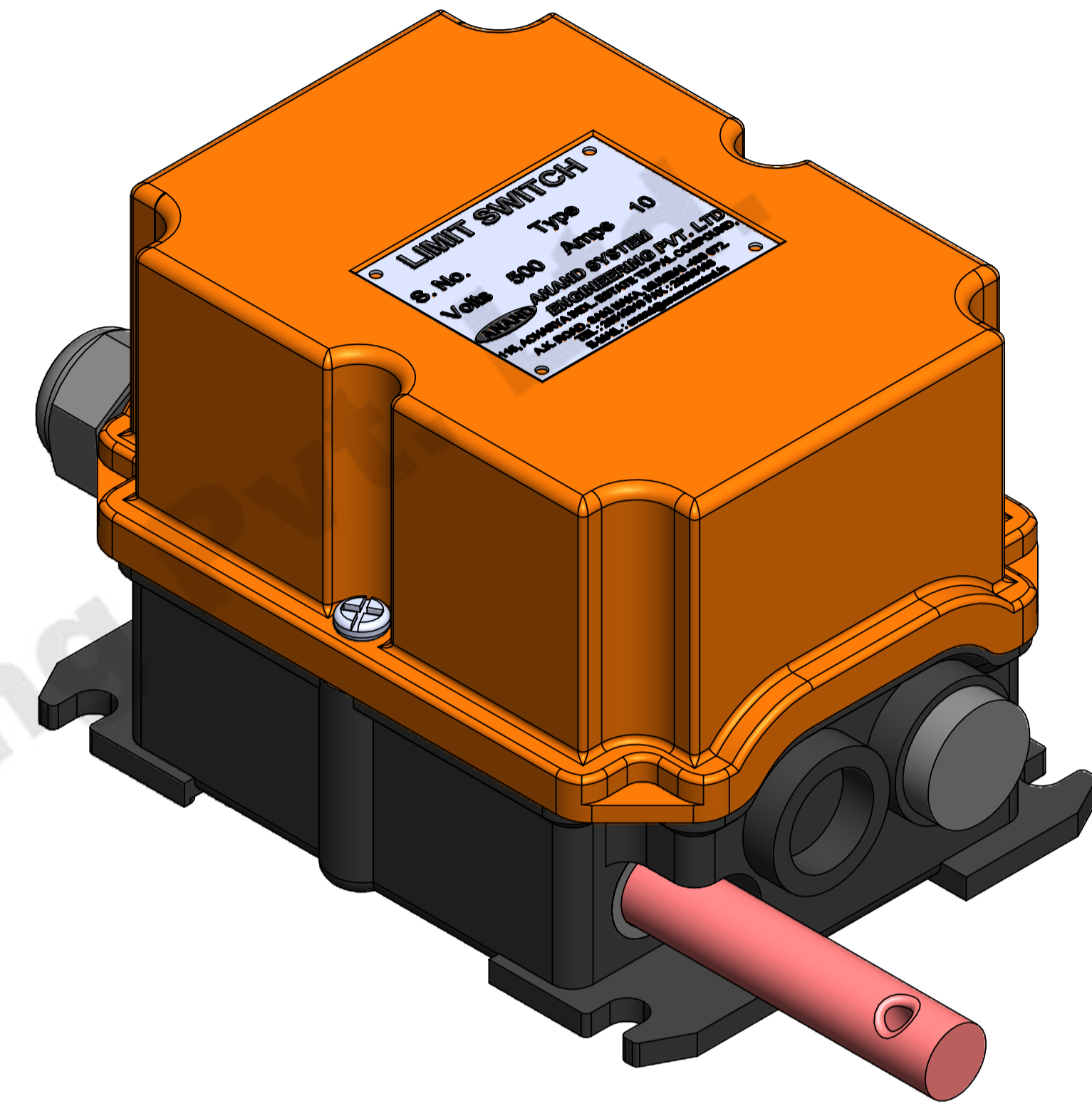
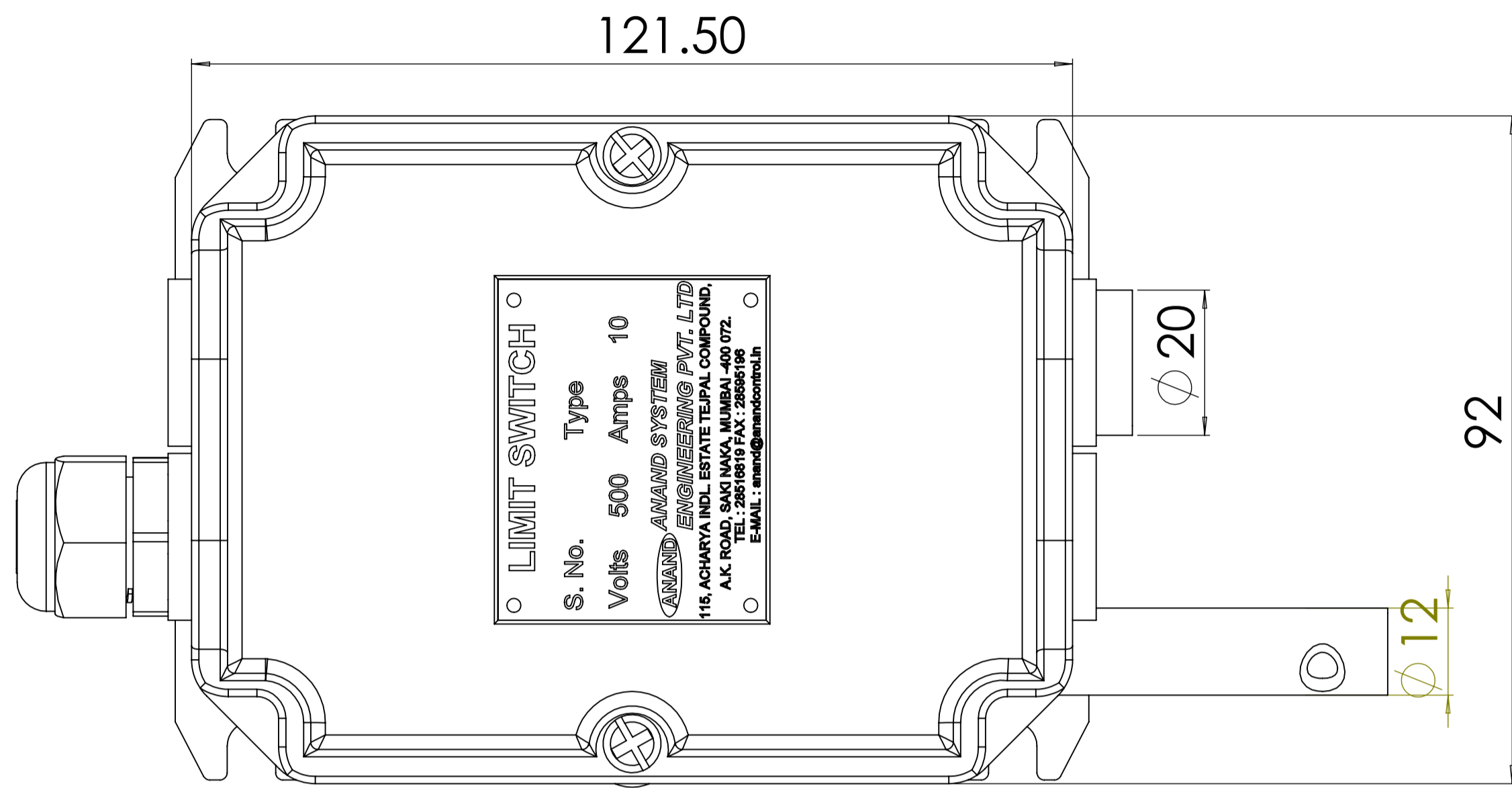

Anand Systems Engineering

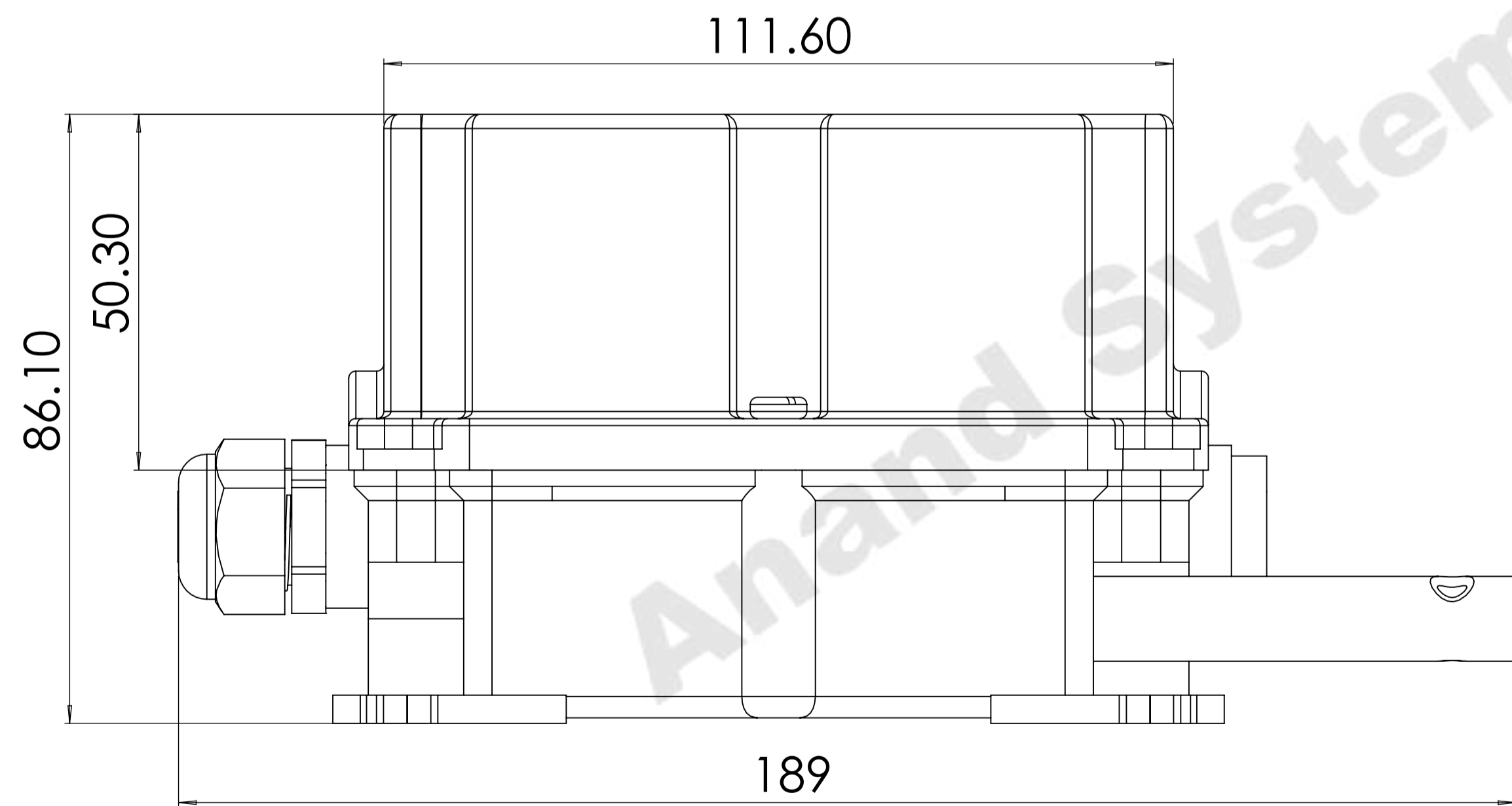

FRONT VIEW

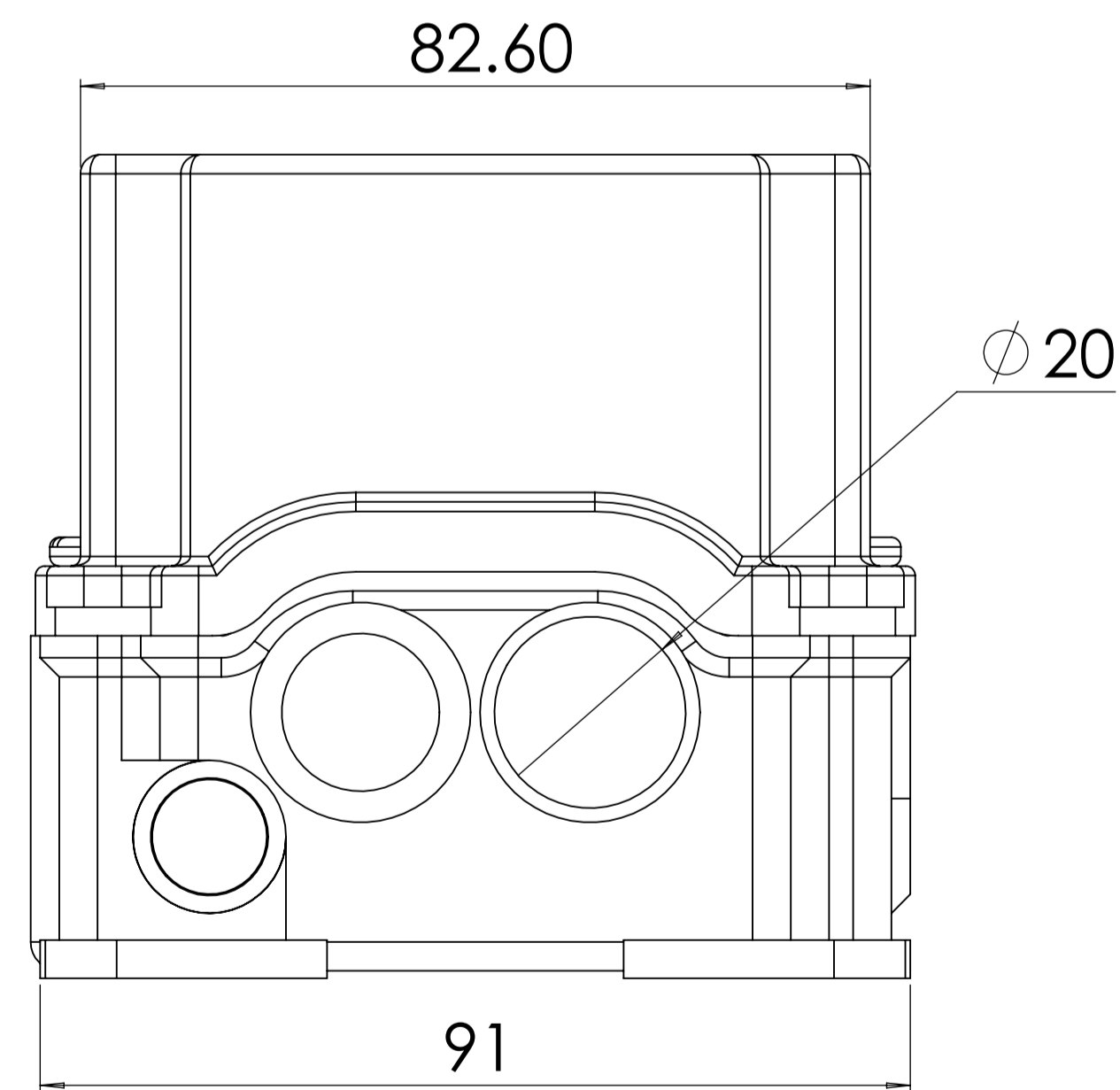

SIDE VIEW

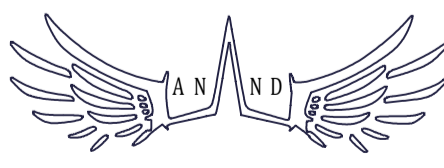
COMPANY NAME:  ANAND SYSTEM ENGINEERING PVT LTD		DO NOT SCALE DRAWING	REVISION:
Email id: info@anandcontrol.in		TITLE: FG 200 P2 ASEMBLY 2D	
CONTACT NO: 9137620579		DWG. NO.	DATE: 27-11-2024
DRWN: SAURABH	MATERIAL:	SIGNATURE:	A
CHKD:	WEIGHT:	SCALE:	SHEET: 1 OF 1