

EXPLODED VIEW

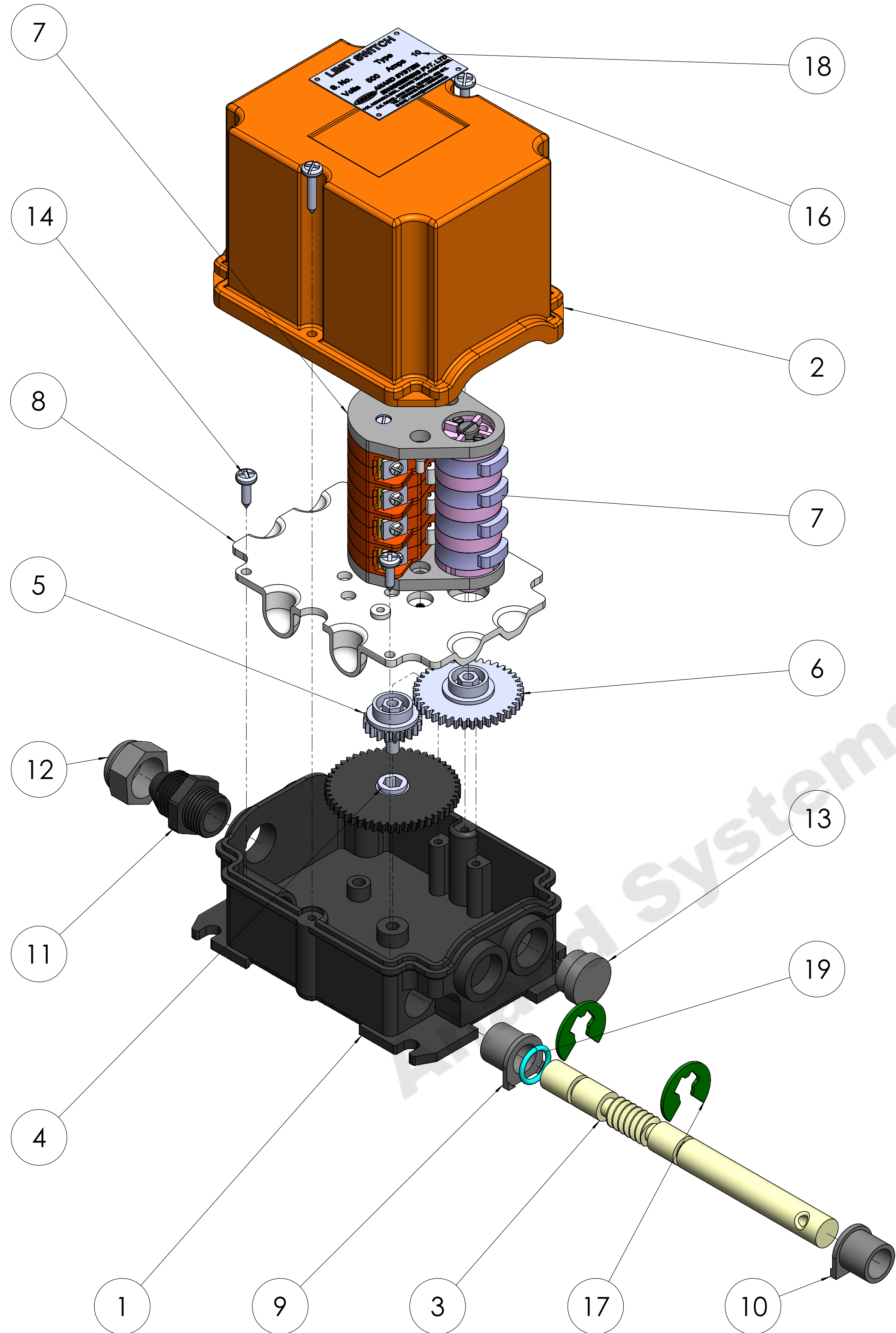

ITEM NO.	PART NAME	DESCRIPTION	Material	QTY.
1	BOTTOM COVER	126X91X45	THERMO PLASTIC	1
2	TOP COVER	122X92X80	THERMO PLASTIC	1
3	WORM SHAFT	143X ϕ 12, SINGLE THREAD 6 TURN	M.S.	1
4	GEARS WARM WHEEL	ϕ 51, 50 TEETH	THERMO PLASTIC	1
5	TOP GEAR	ϕ 22, 20TEETH	THERMO PLASTIC	1
6	GEARS WARM WHEEL	ϕ 41.5, 40TEETH	THERMO PLASTIC	1
7	FG CONTACT BLOCK ASSEMBLY (FG 100 P4)	47X30X7	THERMO PLASTIC	1
8	FG ASSEMBLY PLATE	109X82X3	THERMO PLASTIC	1
9	GEAR SHAFT BUSH CLOSE	15.5X ϕ 16	THERMO PLASTIC	1
10	GEAR SHAFT BUSH OPEN	15X ϕ 16	THERMO PLASTIC	1
11	CABLE GLAND	ϕ 16.5X30	THERMO PLASTIC	1
12	CABLE GLAND NUT	HEX-21X15	THERMO PLASTIC	1
13	GRUMET CAP	ϕ 20X 11	THERMO PLASTIC	1
14	SCREW	SELF THREADED 8X13	M.S.	4
15	STAR SCREW	M4X6.5	M.S.	2
16	SCREW	SELF THREADED 8X19	M.S.	2
17	E CIRCLIP 8mm	8X25	SPRING STEEL	2
18	NAME PLATE	47X37	ALUMINIUM	1
19	O RING	ϕ 12mm	RUBBER	1

CONTACT BLOCK ASSEMBLY

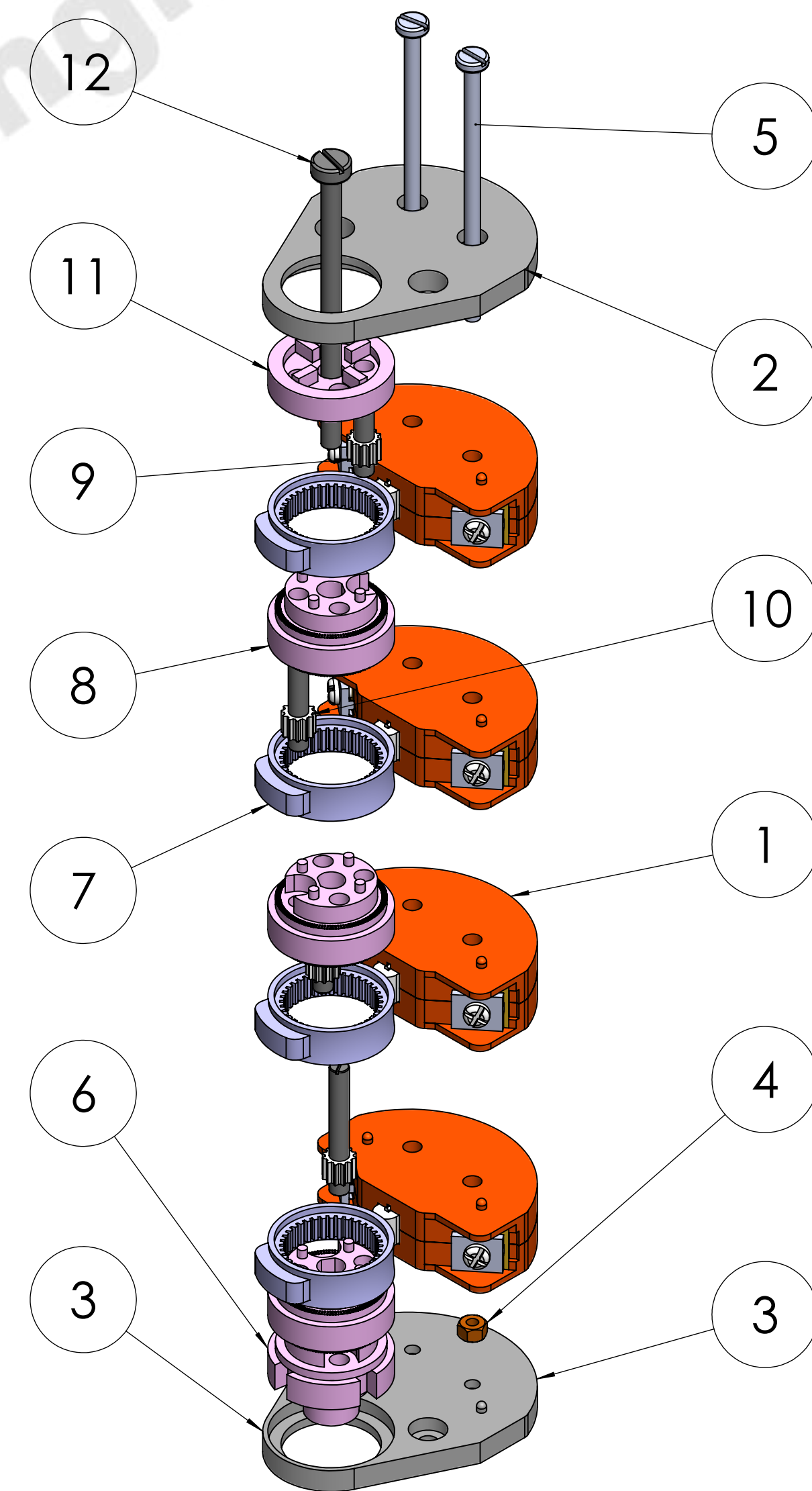

ITEM NO.	PART NAME	DESCRIPTION	Material	QTY.
1	CONTACT BLOCK ASSEMBLY	P4	THERMO PLASTIC	4
2	TOP GUIDE CAM PLATE	47X60X5	THERMO PLASTIC	1
3	BASE GUIDE CAM PLATE	47X60X5	THERMO PLASTIC	1
4	M3 NUT	ϕ 3 mm	M.S.	2
5	M3 SCREW	3X60	M.S.	2
6	BASE CAM SET ASSEMBLY	ϕ 25X20.5X ID- ϕ 7	THERMO PLASTIC	1
7	GEAR RING CAM SET	ϕ 25X ϕ 19X8	THERMO PLASTIC	4
8	MIDDLE BASE CAM SET ASSEMBLY	ϕ 25X15	THERMO PLASTIC	3
9	S.S.PIN	4X16	M.S.	2
10	S.S.PIN	4X30	M.S.	2
11	TOP CAM SET ASSEMBLY	ϕ 25X7.5	THERMO PLASTIC	1
12	SCREW CHZ	4X65	M.S.	1
13	M4 NUT	ϕ 4mm	M.S.	1

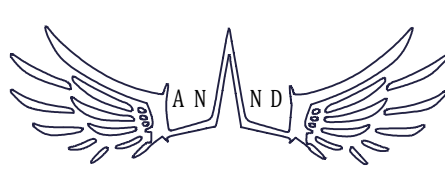
COMPANY NAME:  ANAND SYSTEM ENGINEERING PVT LTD

DO NOT SCALE DRAWING

TITLE: FG 100 P4 ASEMBLY 2D

EMAIL ID: info@anandcontrol.in

CONTACT NO: 9137620579

DATE: 27-11-2024

SHEET: 1 OF 1

TOP VIEW

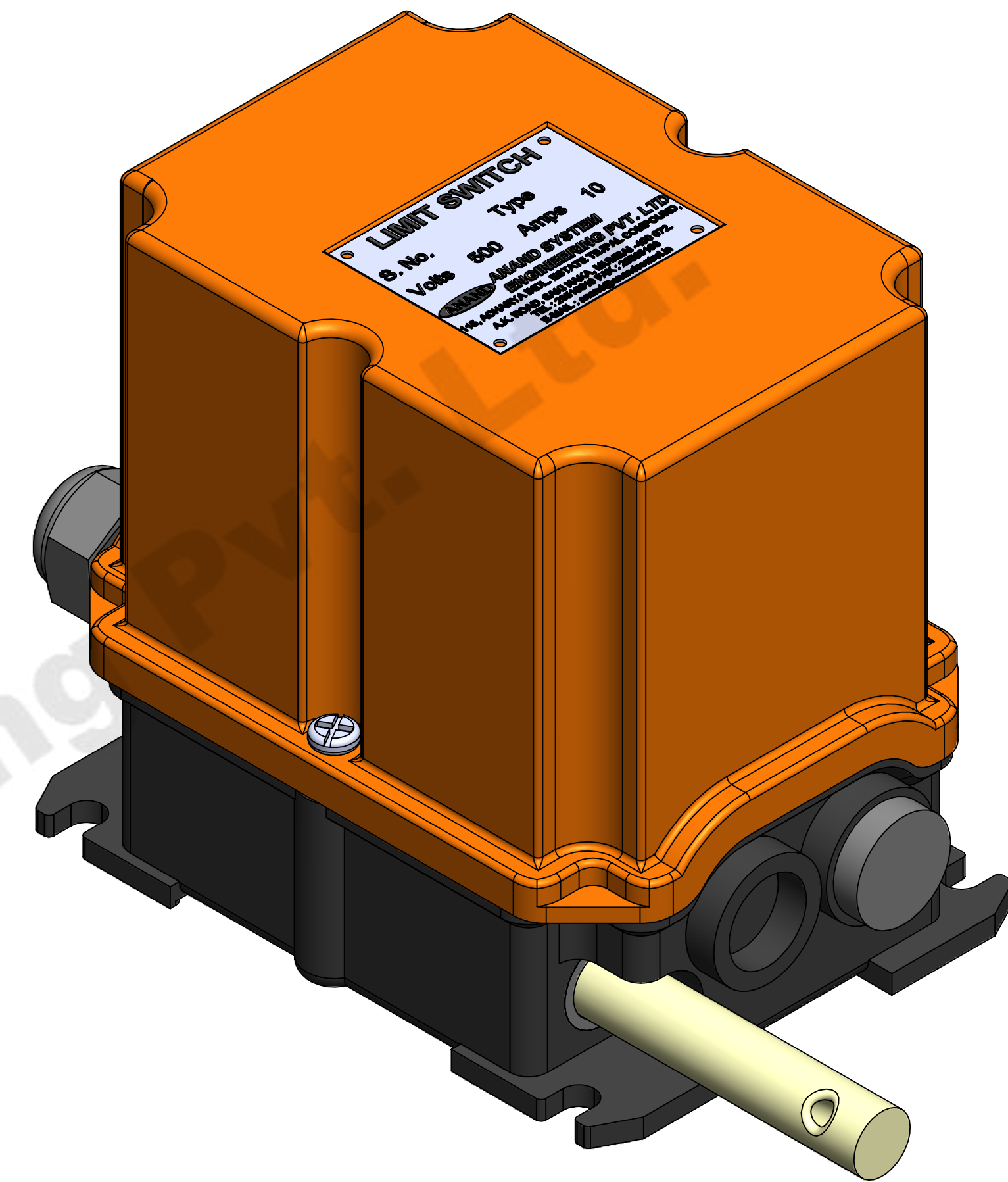
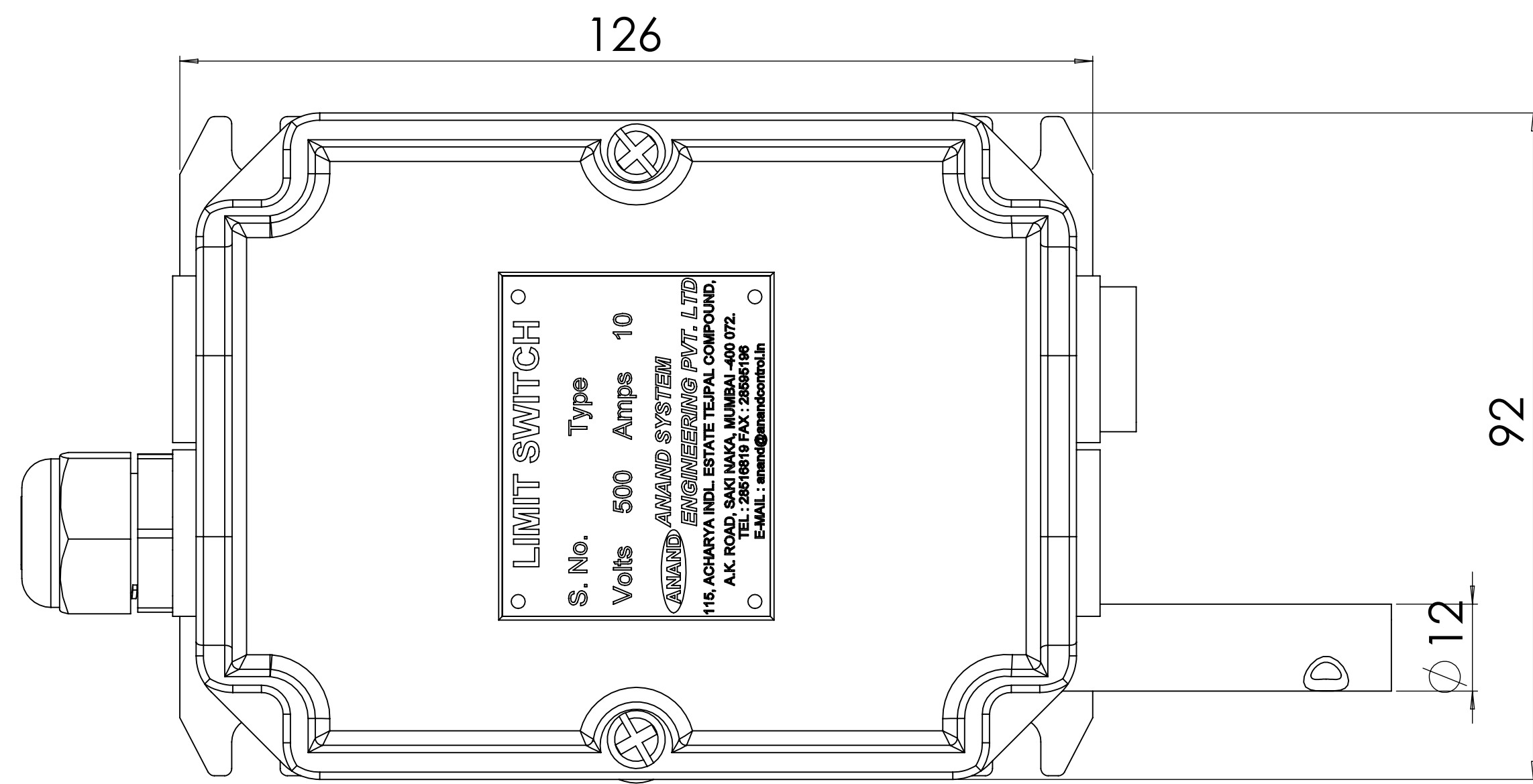

FRONT VIEW

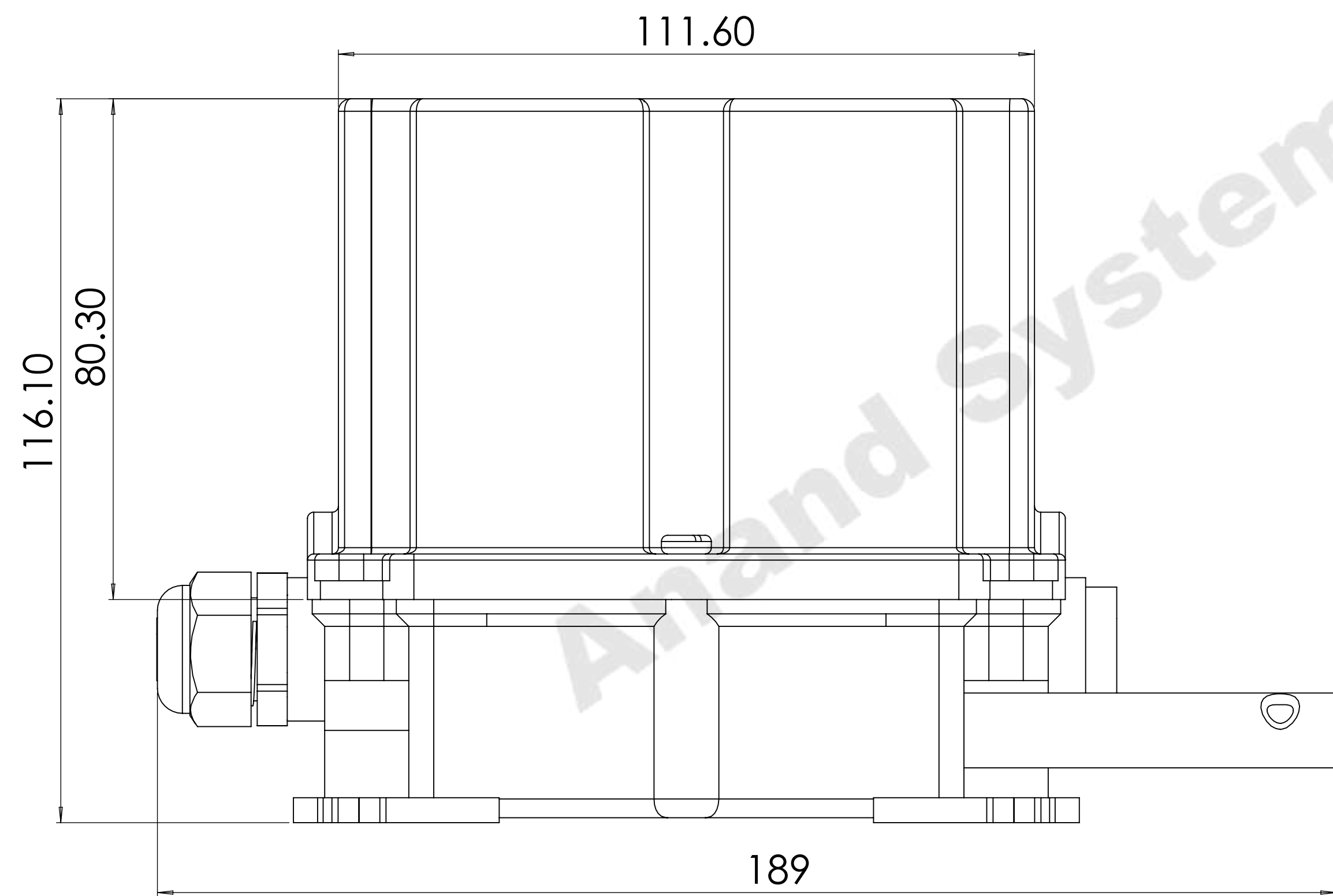

SIDE VIEW

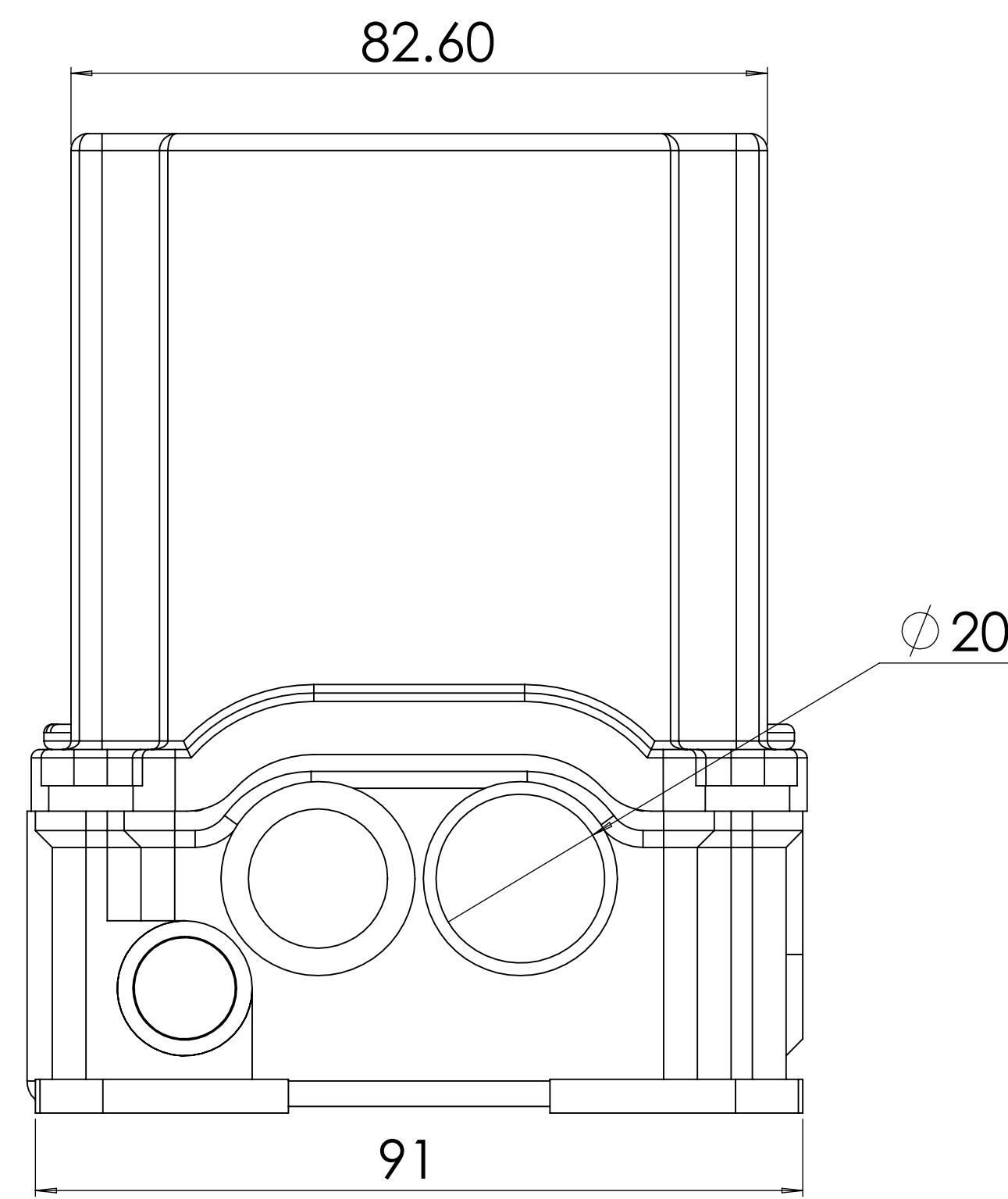

COMPANY NAME:		ANAND SYSTEM ENGINEERING PVT LTD		DO NOT SCALE DRAWING	REVISION:
Email id: info@anandcontrol.in		CONTACT NO: 9137620579		TITLE: FG 100 P4 ASEMBLY 2D	
DRAWN: SAURABH		MATERIAL:		DATE: 27-11-2024	
CHKD:		WEIGHT:		SIGNATURE:	
APPRD:		SCALE:		SHEET: 1 OF 1	
MFC:				A	