

EXPLODED VIEW

ITEM NO.	PART NUMBER	DESCRIPTION	MATERIAL	QTY.
1	BASE	780X205X81	M.S.	1
2	BASE PIN	16X125	M.S.	2
3	BASE PIN	16X160	M.S.	1
4	BRAKE LINER	10X180	ASBESTOS	2
5	BRAKE SHOE	400X180	CAST IRON	2
6	SPRING	COMPRESS SPRING ϕ 6MM COIL, 57X 318X 21 TURNS	SPRING STEEL	2
7	GUIDE PLATE	220X50X12	M.S.	2
8	HEX BOLT	M 10, 10X50	M.S.	2
9	HEX BOLT	M 16, 16X50	M.S.	2
10	HEX NUT	G.I. M16	M.S.	21
11	LEVER	400X8	M.S.	2
12	LEVER PIN	16X70	M.S.	3
13	LUG	M20 TAP, SQ30X30, 60MM LONG	M.S.	2
14	M.S.BUSH FOR LUG	21X25, THK-5	M.S.	4
15	M.S.BUSH FOR THRUSTER	22X25, THK-5.5	M.S.	2
16	MAIN ARM	590X80X75 THK-8	M.S.	1
17	LEVER PIN	20X100 FOR MAIN ARM	M.S.	1
18	NAME PLATE	115X20	ALUMINIUM	1
19	NAME PLATE	70X20	ALUMINIUM	1
20	NAME PLATE RIVET	L-4.5 MM	ALUMINIUM	4
21	PLAIN WASHER	37X20.5X1.5	M.S.	18
22	PLAIN WASHER	55X32X1.5	M.S.	6
23	SHOE PIN	20X160	M.S.	2
24	SHOE SUPPORT	30X20	M.S.	2
25	SIDE ARM	600X80X65 THK-8	M.S.	1
26	SIDE ARM BUSH	40X40X64	M.S.	1
27	SPACER PIN	20X100, MIDDLE-38 M16	M.S.	2
28	SPRING WASHER	M10	SPRING STEEL	2
29	SPRING WASHER	M16	SPRING STEEL	4
30	THRUSTER PIN	19X70	M.S.	2
31	TIE ROD	L-400 X 16MM	M.S.	2
32	TIE ROD.1	L-450 X 16MM	M.S.	1
33	AL SHOE RIVET	15X6	ALUMINIUM	16
34	TIE ROD.1	L-380 X 16MM	M.S.	1
35	LUG	M20 TAP, SQ30X30, 90MM LONG	M.S.	2
36	COTTER PIN	1/8" X 1 1/4"	M.S.	16
37	COTTER PIN	1/8" X 1 1/2"	M.S.	6
38	SPRING	COMPRESS SPRING ϕ 5MM COIL, 36X 318X 22 TURNS	SPRING STEEL	2
39	68 KG THRUSTER 400-68	68 KG THRUSTER ASSEMBLY	-	1

COMPANY NAME: **ANNAD SYSTEM ENGINEERING PVT LTD**

DO NOT SCALE DRAWING

REVISION:

TITLE: **MDT 400-68 KG BRAKE ASSEMBLY 2D**

EMAIL ID: info@anandcontrol.in

CONTACT NO. 9137620579

DATE: _____ SIGNATURE: _____

SCALE: 1:15 SHEET 1 OF 2

DRAWN: _____ CHECKED: _____ APPROVED: _____ G.A. _____ MATERIAL: _____ WEIGHT: _____

A1

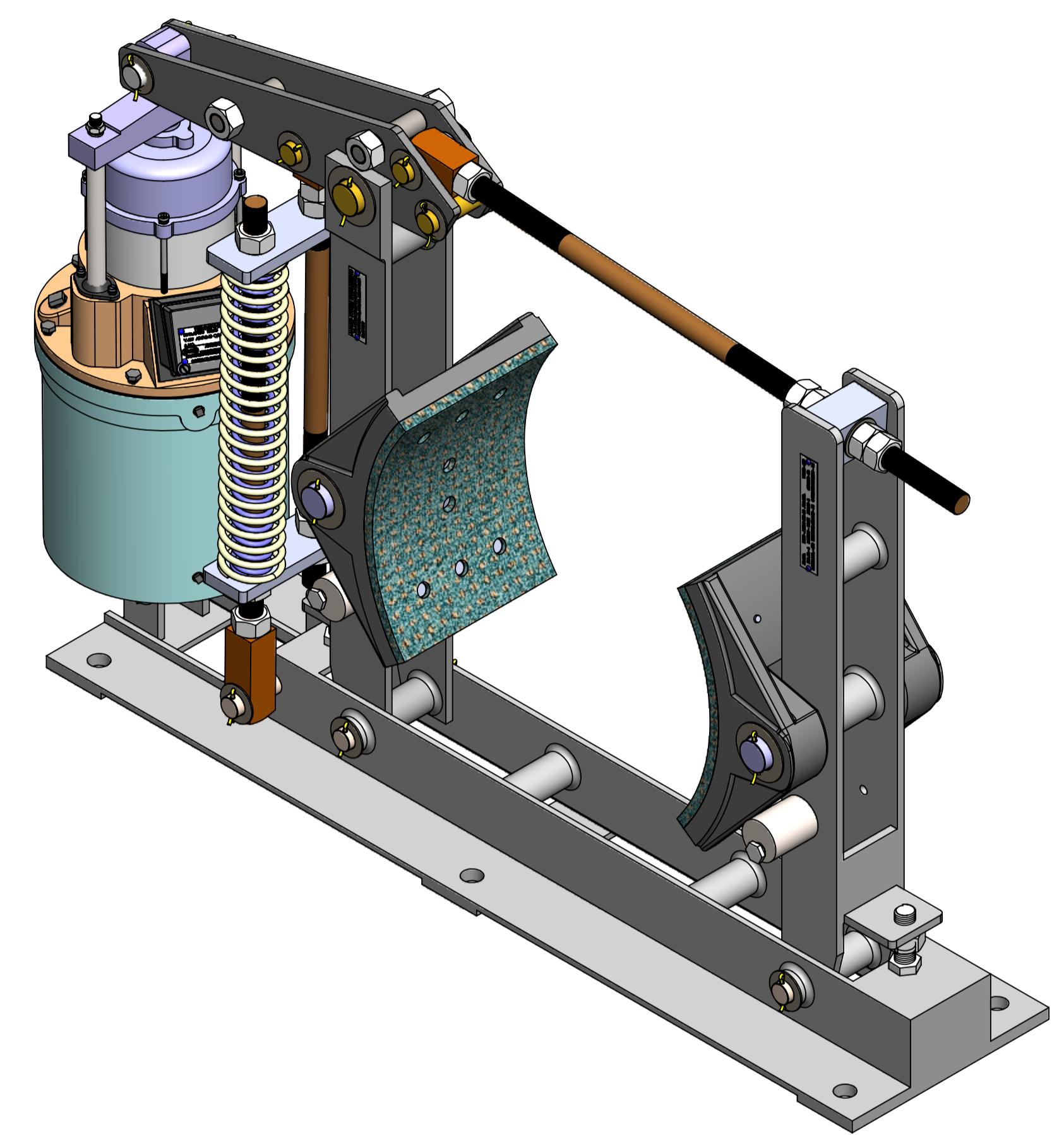
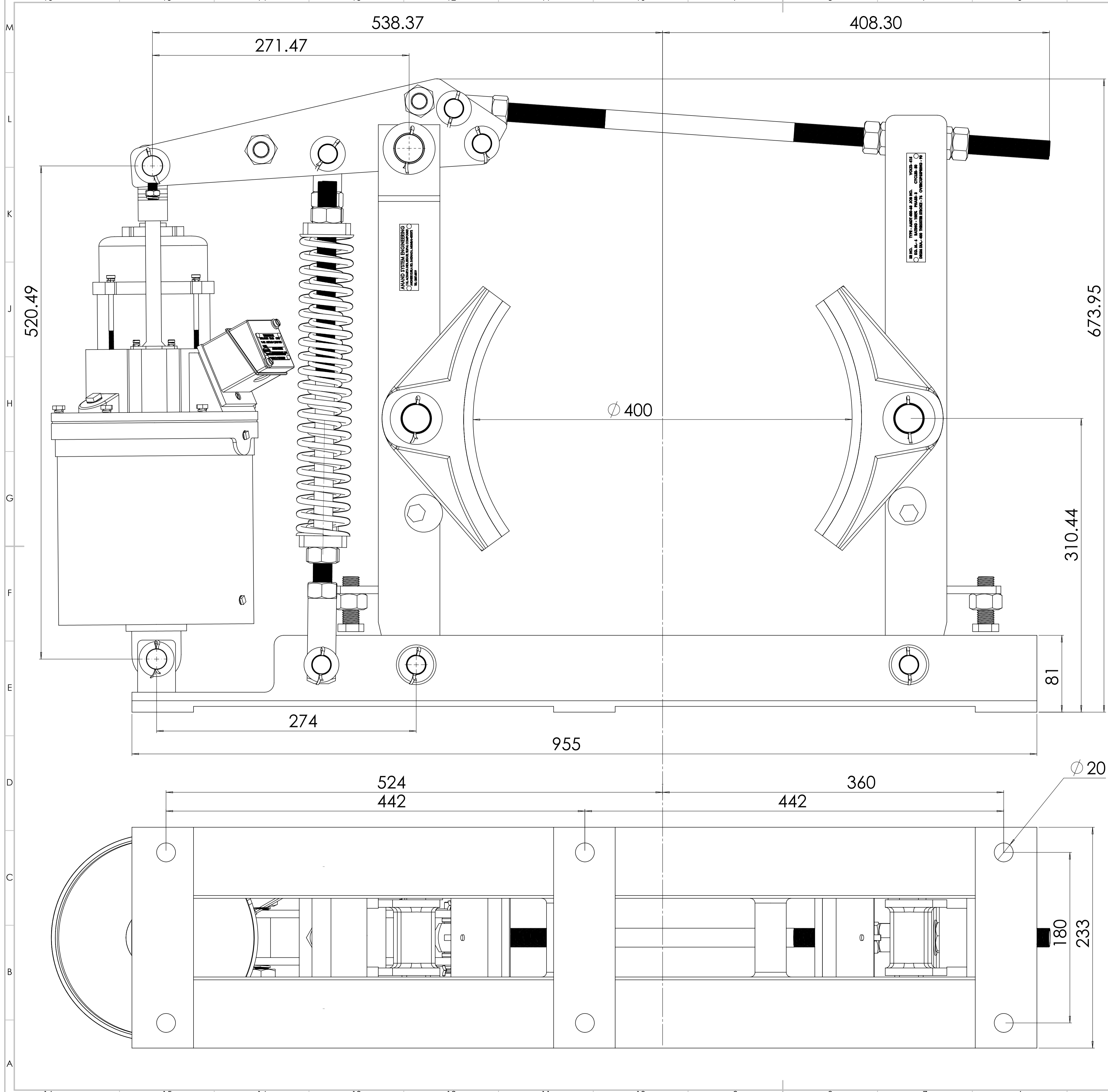

COMPANY NAME:		ANAND SYSTEM ENGINEERING PVT LTD		DO NOT SCALE DRAWING	REVISION
Email id: info@anandcontrol.in		CONTACT NO: 9137620579		TITLE: MDT 400-68 KG BRAKE ASSEMBLY 2D	
DRAWN:	CHKD:	APPRD:	G.A.	DATE:	SIGNATURE:
MATERIAL:			WEIGHT:		
SCALE: 1:15				SHEET 2 OF 2	