

EXPLODED VIEW

ITEM NO.	PART NUMBER	DESCRIPTION	MATERIAL	QTY.
1	BASE	780X230X75	M.S.	1
2	BASE PIN	20X135	M.S.	2
3	BASE PIN	20X200	M.S.	1
4	BRAKE LINER	10X180	ASBESTOS	2
5	BRAKE SHOE	400X180	CAST IRON	2
6	SPRING	COMPRESS SPRING ϕ 6MM COIL, 57X 310X 21 TURNS	SPRING STEEL	2
7	GUIDE PLATE	220X50X12	M.S.	2
8	HEX BOLT M8	M 10, 10X50	M.S.	2
9	HEX BOLT	M 16, 16X50	M.S.	2
10	HEX NUT	G.I. M20	M.S.	21
11	LEVER	400X8	M.S.	2
12	LEVER PIN	20X75	M.S.	3
13	LUG	M16 TAP, SQ30X30, 60MM LONG	M.S.	2
14	M.S.BUSH FOR LUG	21X16.5X5	M.S.	4
15	M.S.BUSH FOR THRUSTER	25X21X7.5	M.S.	2
16	MAIN ARM	590X80X75 THK-6	M.S.	1
17	LEVER PIN	FOR MAIN ARM 30X111	M.S.	1
18	NAME PLATE	115X20	ALUMINIUM	1
19	NAME PLATE	70X20	ALUMINIUM	1
20	NAME PLATE RIVET 400-34	L-4.5 MM	ALUMINIUM	4
21	PLAIN WASHER	37X20.5X1.5	M.S.	18
22	PLAIN WASHER	55X32X1.5	M.S.	6
23	SHOE PIN	30X200	M.S.	2
24	SHOE SUPPORT	40X50	M.S.	2
25	SIDE ARM	600X80X65	M.S.	1
26	SIDE ARM BUSH	SQ-40X40, L-64	M.S.	1
27	SPACER PIN	O.D20X38, M16 L-100	M.S.	2
28	SPRING WASHER	M10	SPRING STEEL	2
29	SPRING WASHER	M12	SPRING STEEL	4
30	THRUSTER PIN	12.7X80	M.S.	2
31	TIE ROD.1	L-330 X 12MM	M.S.	2
32	TIE ROD.1	L-330 X 12MM	M.S.	1
33	AL SHOE RIVET	15X6	ALUMINIUM	16
34	TIE ROD.1	L-330 X 12MM	M.S.	1
35	LUG	M16 TAP, SQ30X30X, 90MM LONG	M.S.	2
36	COTTER PIN 1	1/8" X 1 1/2"	M.S.	16
37	COTTER PIN 2	1/8" X 2"	M.S.	6
38	NEW 34KG THRUSTER ASSEMBLY 400-34	-	-	1
39	SPRING	COMPRESS SPRING ϕ 5MM COIL, 35X 310X 22 TURNS	SPRING STEEL	2

COMPANY NAME		ANAND SYSTEM ENGINEERING PVT LTD	
EMAIL ID: info@anandcontrol.in		CONTACT NO: 9137620579	
TITLE: 400-34 BRAKE ASSEMBLY 2D		SCALE: 1:1	
DATE: _____	DRAWN: _____	CHECKED: _____	APPROVED: _____

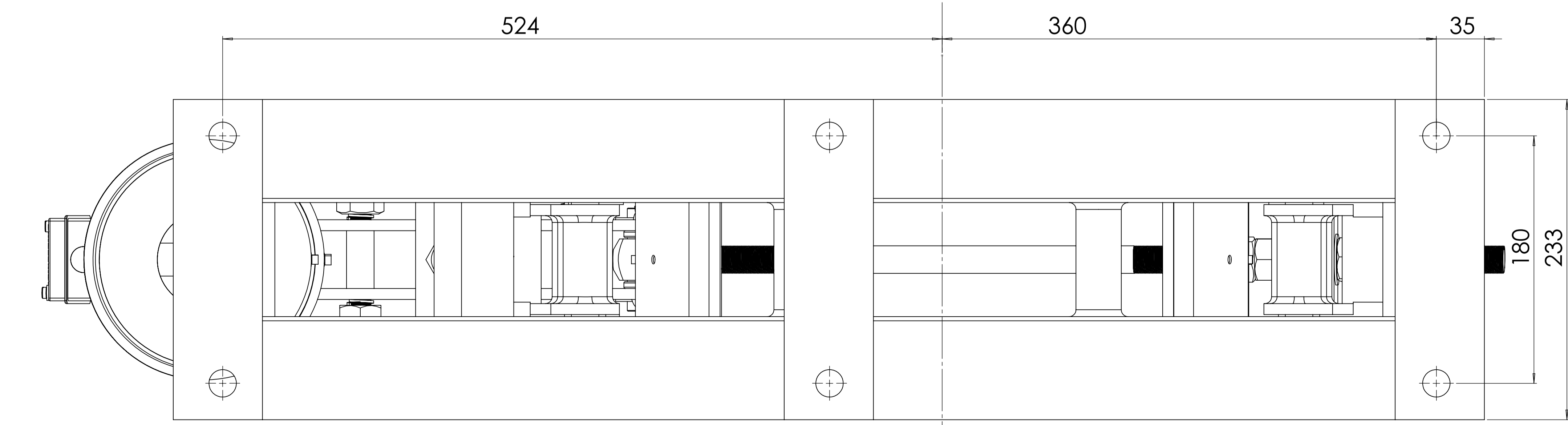
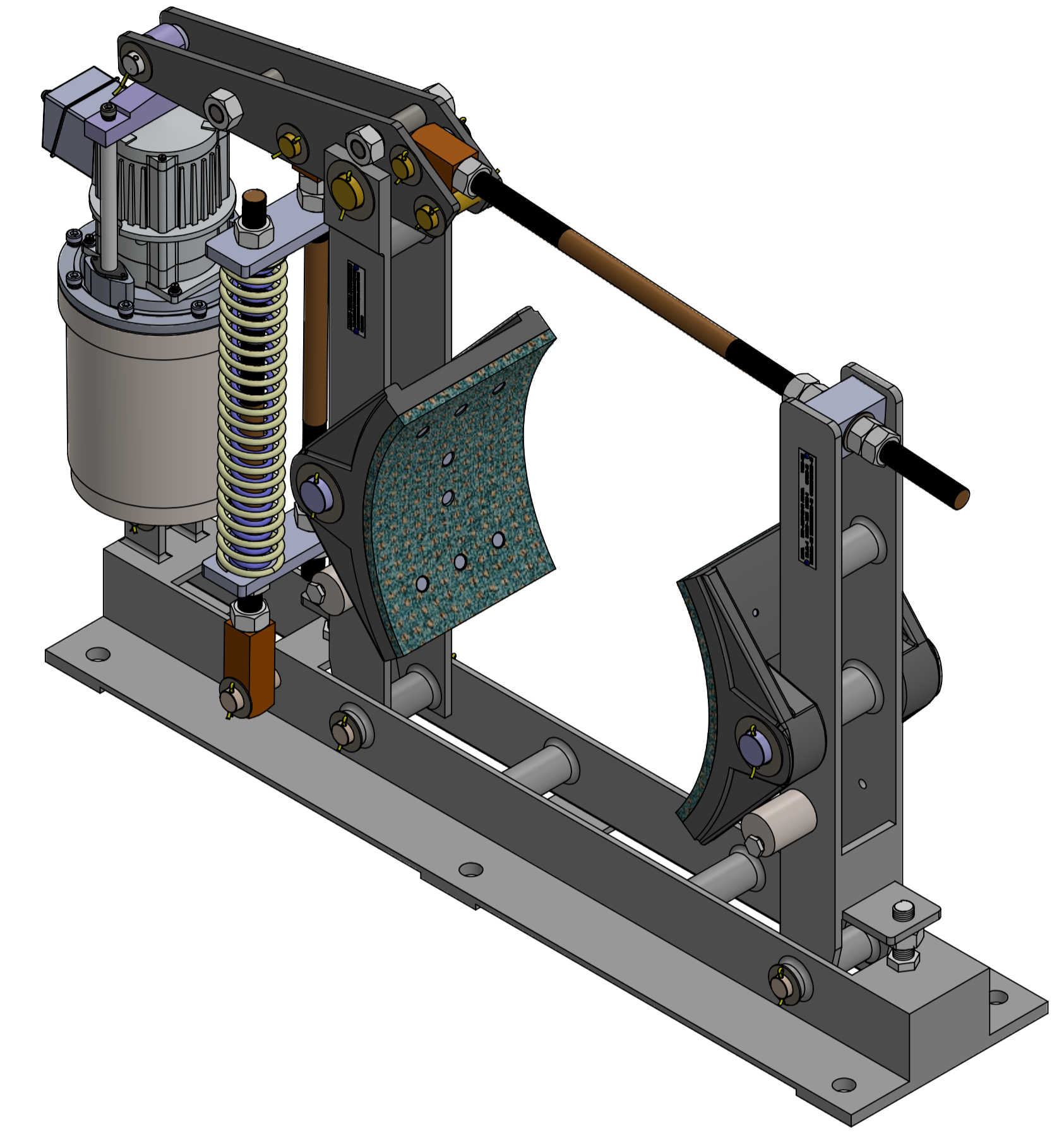
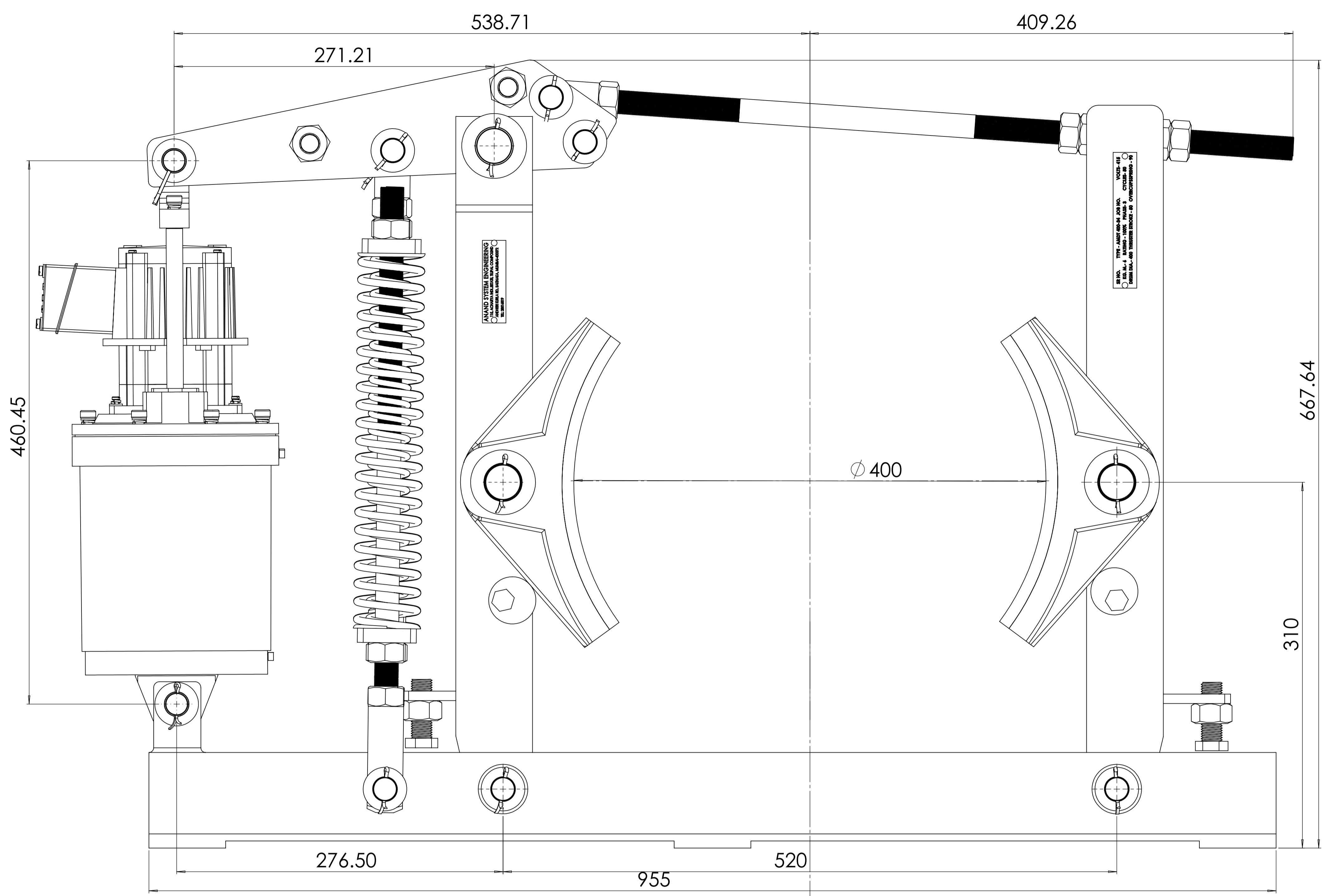

COMPANY NAME		ANAND SYSSTEM ENGINEERING PVT LTD		DO NOT SCALE DRAWING	REVISION
Email id: info@anandcontrol.in		CONTACT NO: 9137620579		TITLE: 400-34 BRAKE ASSEMBLY 2D	
APPROV'D	DATE	SCALE: 1:2	WEIGHT	DATE	SIGNATURE
DESN					
TRG					
QA					
			A1		
			SHEET 2 OF 2		