

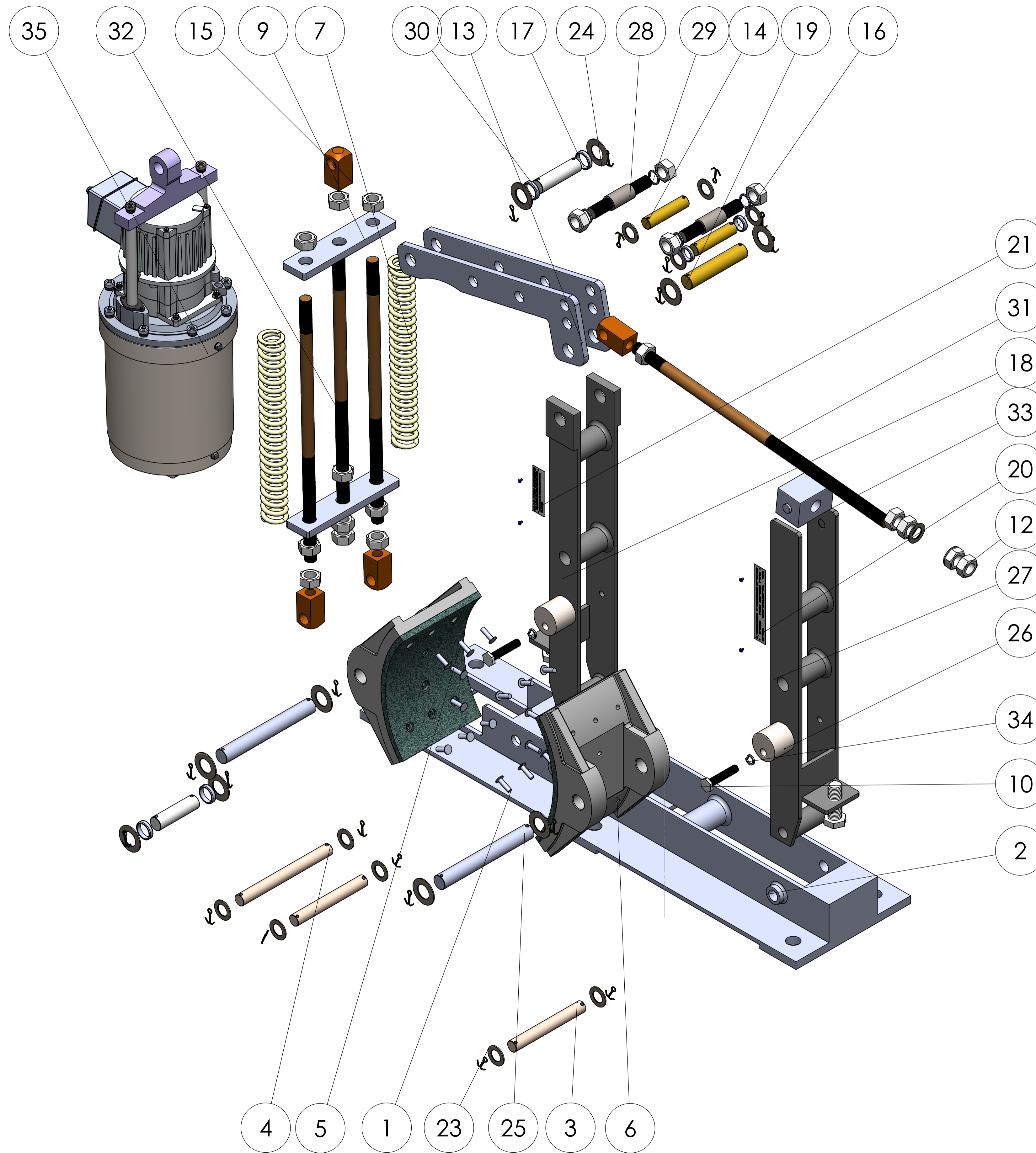

EXPLODED VIEW



| ITEM NO. | PART NUMBER | DESCRIPTION | MATERIAL | QTY. |
|----------|-----------------------------------|--|--------------|------|
| 1 | AL SHOE RIVET | 15X6 | ALUMINIUM | 16 |
| 2 | BASE | 780X205X65 | M.S. | 1 |
| 3 | BASE PIN | 20X100 | M.S. | 2 |
| 4 | BASE PIN | 16X160 | M.S. | 1 |
| 5 | BRAKE LINER | 8X140MM | ASBESTOS | 2 |
| 6 | BRAKE SHOE | 300X140 | CAST IRON | 2 |
| 7 | SPRING | COMPRESS SPRING ϕ 6MM COIL, 35X 275X 22 TURNS | SPRING STEEL | 2 |
| 8 | COTTER PIN | 1/8" X 1-1/4" | M.S. | 20 |
| 9 | GUIDE PLATE | 165X40X10 | M.S. | 2 |
| 10 | HEX BOLT | M 10, 10X50 | M.S. | 2 |
| 11 | HEX BOLT | M 16, 16X50 | M.S. | 2 |
| 12 | HEX NUT | G.I. M16 | M.S. | 19 |
| 13 | LEVER | 325X8 | M.S. | 2 |
| 14 | LEVER PIN | 16X70 | M.S. | 2 |
| 15 | LUG | M16 TAP, SQ25X25, 50MM LONG | M.S. | 4 |
| 16 | M.S.BUSH FOR LUG | 21X17X5.5 | M.S. | 2 |
| 17 | M.S.BUSH FOR THRUSTER | 25X21X5 | M.S. | 4 |
| 18 | MAIN ARM | 480X72X6 B-50 | M.S. | 1 |
| 19 | LEVER PIN | 20X100 FOR MAIN ARM | M.S. | 1 |
| 20 | NAME PLATE | 115X20 | ALUMINIUM | 1 |
| 21 | NAME PLATE | 70X20 | ALUMINIUM | 1 |
| 22 | NAME PLATE RIVET 400-34 | L-4.5 MM | ALUMINIUM | 4 |
| 23 | PLAIN WASHER | 28X16.5X1.5 | M.S. | 12 |
| 24 | PLAIN WASHER | 37X20.5X1.5 | M.S. | 10 |
| 25 | SHOE PIN | 20X160 | M.S. | 2 |
| 26 | SHOE SUPPORT | 40X35 | M.S. | 2 |
| 27 | SIDE ARM | 490X72X6 B-50 | M.S. | 1 |
| 28 | SPACER PIN | O.D-20X38, M16, L-100 | M.S. | 2 |
| 29 | SPRING WASHER | M16 | SPRING STEEL | 4 |
| 30 | THRUSTER PIN | 19X70 | M.S. | 2 |
| 31 | TIE ROD | L-450 X 16MM | M.S. | 1 |
| 32 | TIE ROD | L-380 X 16MM | M.S. | 1 |
| 34 | SPRING WASHER | M10 | SPRING STEEL | 2 |
| 35 | NEW 34KG THRUSTER ASSEMBLY 300-34 | - | - | 1 |
| 36 | TIE ROD | L-400 X 16MM | M.S. | 2 |

COMPANY NAME

ANAND SYSTEM ENGINEERING PVT LTD

DO NOT SCALE DRAWING REVISION

TITLE:
MDT 300-34 KG BRAKE ASSEMBLY 2D

Email id: info@anandcontrol.in
 CONTACT NO. 9137620579

DATE: _____ SIGNATURE: _____

DRAWN: _____ DWG NO.: _____ A1
 CHKD: _____
 MFG: _____
 APPVD: _____

SCALE: 1:2 SHEET 1 OF 2

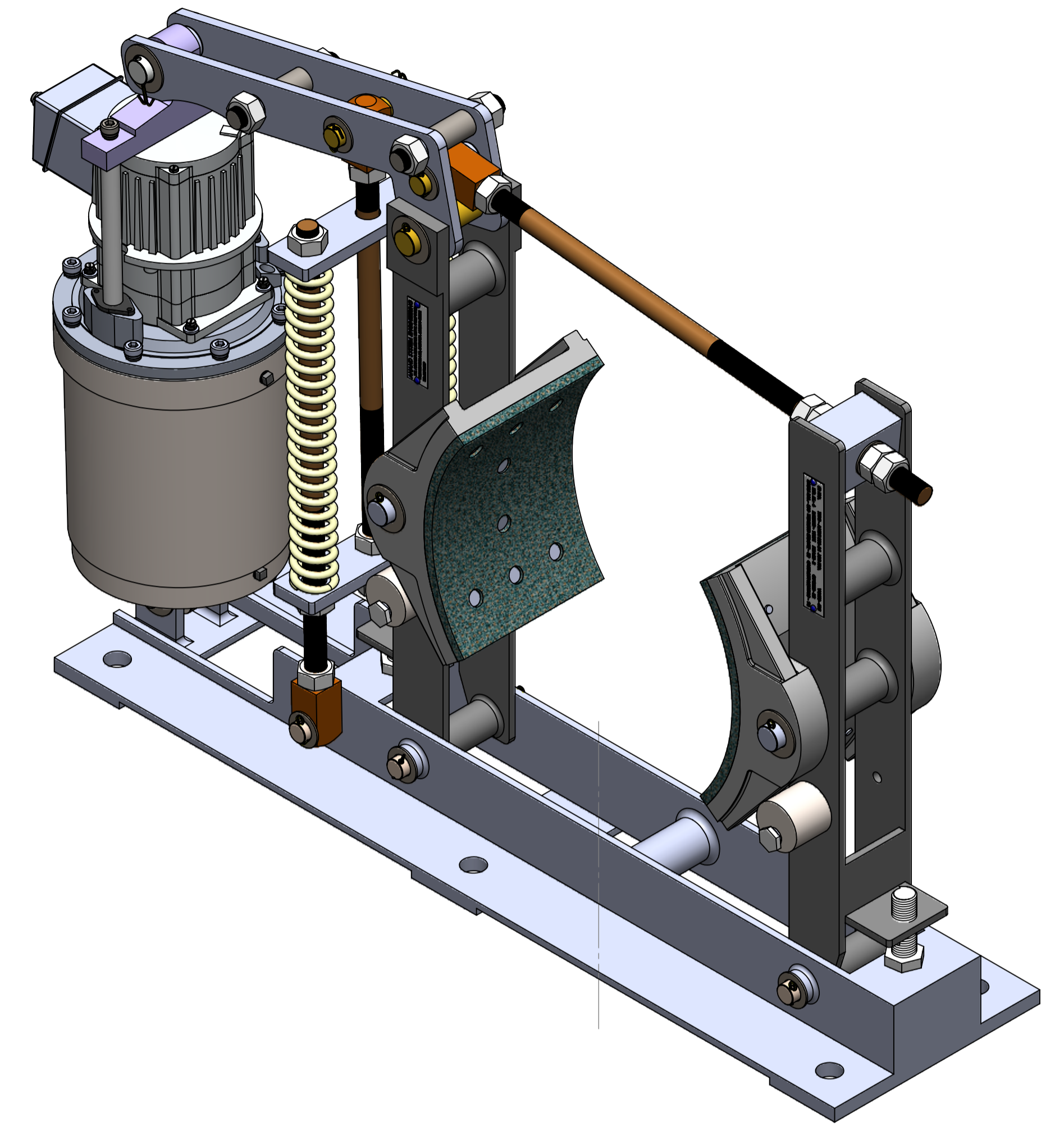
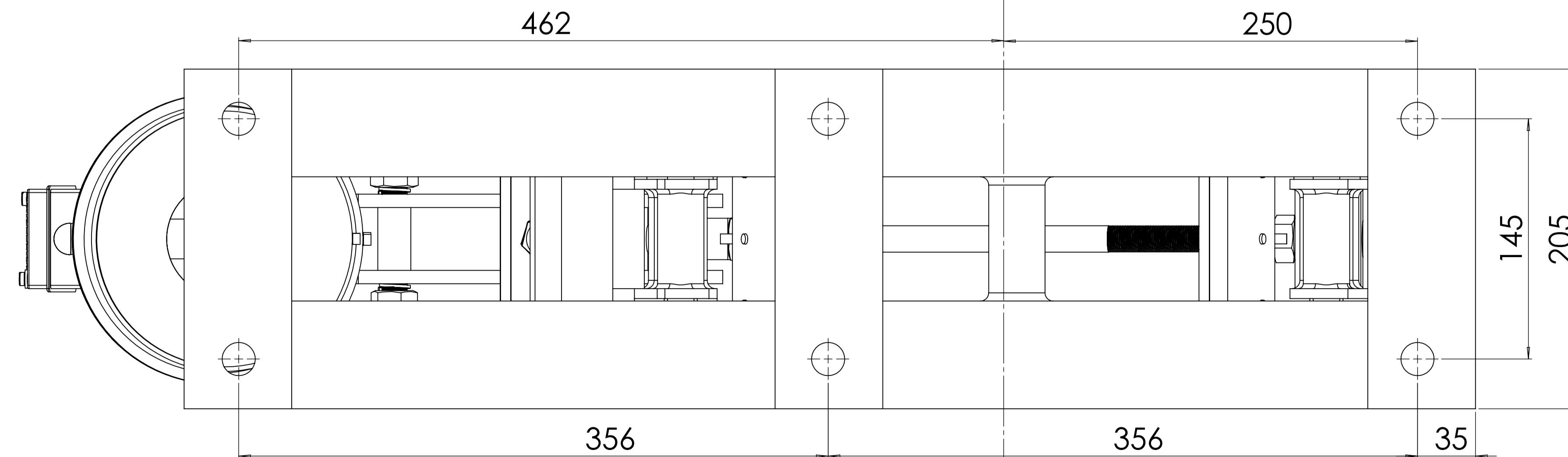
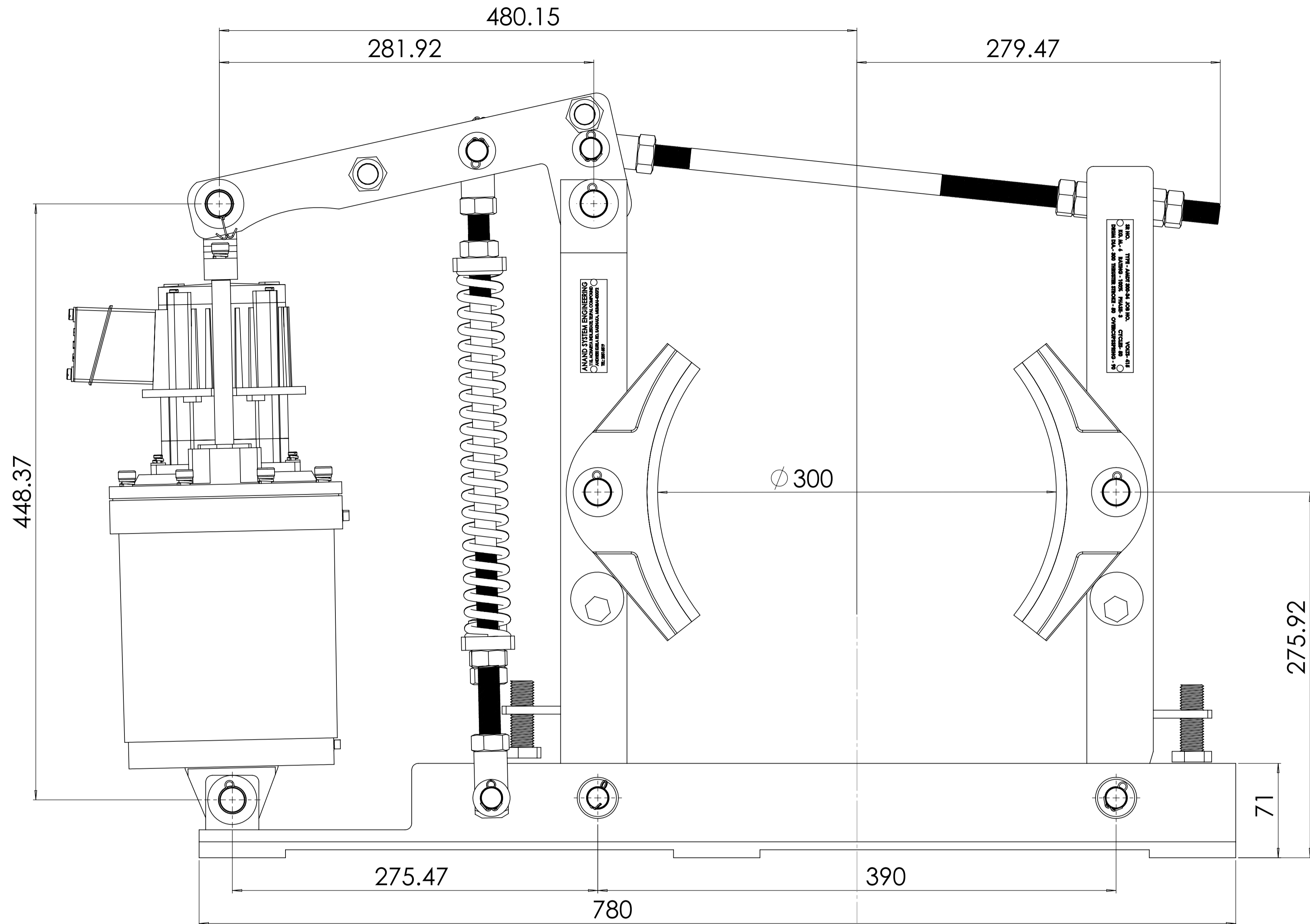

| | | | | |
|---|--|------------------------------------|--------------|----------|
| COMPANY NAME: | | DO NOT SCALE DRAWING | | REVISION |
|  ANAND SYSTEM ENGINEERING PVT LTD | | TITLE: | | |
| | | MDT 300-34 KG BRAKE ASSEMBLY 2D | | |
| Email id: info@anandcontrol.in | | DWG NO. | | |
| CONTACT NO: 9137620579 | | DATE | | |
| DRAWN: | | MATERIAL: | SIGNATURE | |
| CHKD: | | WEIGHT: | A1 | |
| APPVD: | | SCALE:1:2 | SHEET 2 OF 2 | |
| MFG: | | | | |