

EXPLODED VIEW

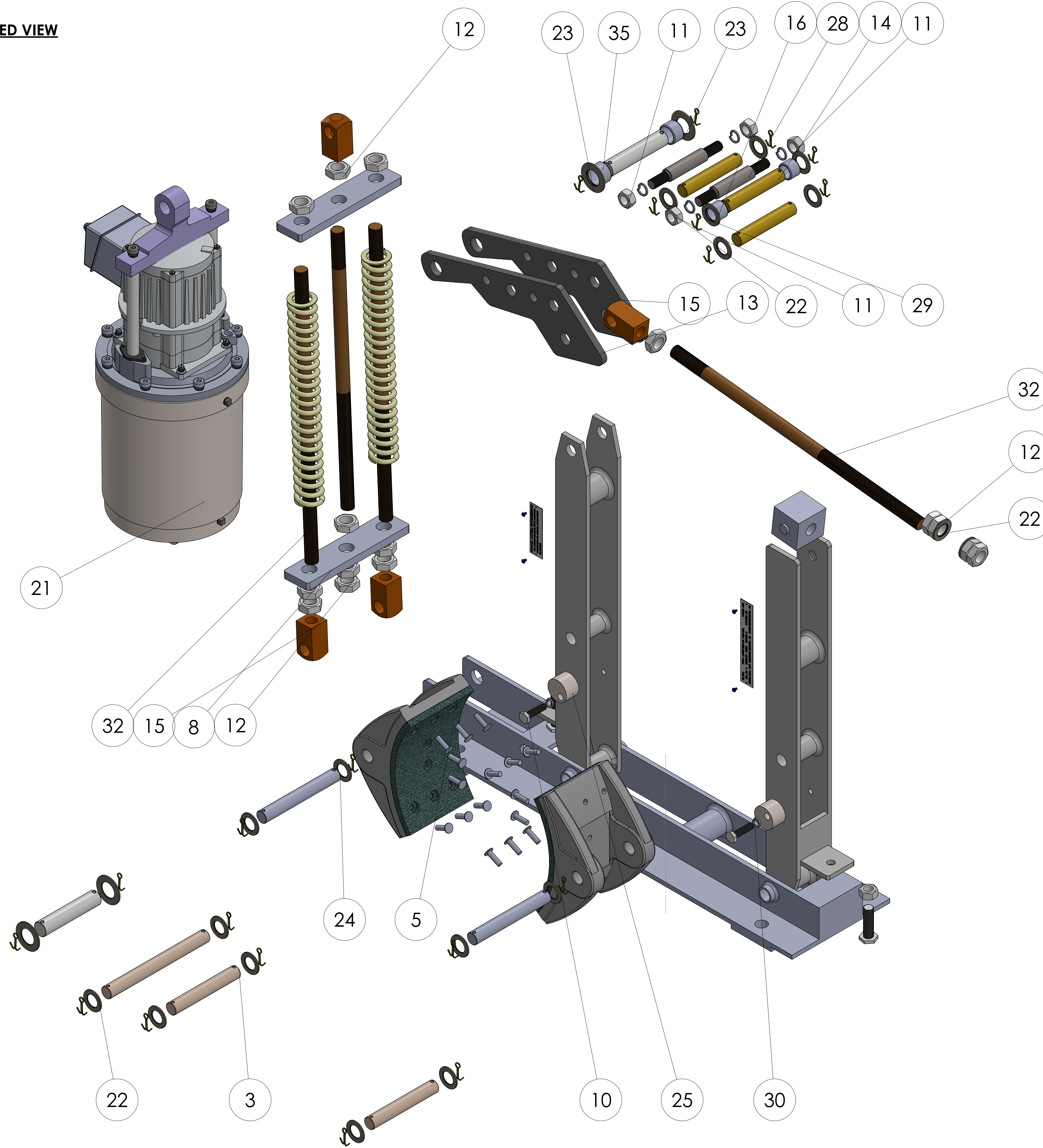

ITEM NO.	PART NAME	DESCRIPTION	MATERIAL	QTY.
1	BASE	640X160X57	M.S.	1
2	BASE PIN	16X160	M.S.	1
3	BASE PIN	16X105	M.S.	2
4	BRAKE LINER	8X102MM	ASBESTOS	2
5	BRAKE SHOE	250X102	CAST IRON	2
6	SPRING	COMPRESS SPRING 6MM COIL, 35X 275X 22 TURNS	SPRING STEEL	2
7	COTTER PIN	1/8" X 11/2"	M.S.	20
8	GUIDE PLATE	165X40X10	M.S.	2
9	HEX BOLT	M 16, 16X40	M.S.	2
10	HEX BOLT	M 8, 8X30	M.S.	2
11	HEX NUT	G.I. M12	M.S.	6
12	HEX NUT	G.I. M16	M.S.	15
13	LEVER	THC-8MM	M.S.	2
14	LEVER PIN	16X90	M.S.	3
15	LUG	M16 TAP, SQ25X25X50	M.S.	4
16	M.S.BUSH FOR LUG	21X16.5X15	M.S.	2
17	MAIN ARM	480X70X50 THC-6MM	M.S.	1
18	NAME PLATE	115X20	ALUMINIUM	1
19	NAME PLATE	70X20	ALUMINIUM	1
20	NAME PLATE RIVET 250-34	L-4.5 MM	ALUMINIUM	4
21	NEW 34KG THRUSTER ASSEMBLY 250-34		-	1
22	PLAIN WASHER	28X16.5X1.5	M.S.	18
23	PLAIN WASHER	37X20.5X1.5	M.S.	4
24	SHOE PIN	16X120	M.S.	2
25	SHOE SUPPORT	30X20	M.S.	2
26	SIDE ARM	490X50 THK-8MM	M.S.	1
27	SIDE ARM BUSH	40X40X38	M.S.	1
28	SPACER PIN	20X100, MIDDLE- 38, M16	M.S.	2
29	SPRING WASHER	M12	SPRING STEEL	4
30	SPRING WASHER	M8	SPRING STEEL	2
31	THRUSTER PIN	12.7X70	M.S.	2
32	TIE ROD.1	L-380 X 16MM	M.S.	3
33	TIE ROD.1	L-400 X 16MM	M.S.	1
34	AL SHOE RIVET	15X6	ALUMINIUM	16
35	M.S.BUSH	FOR THRUSTER 25X21X15	M.S.	2
36	COTTER PIN	1/8 X 11/4"	M.S.	6

COMPANY NAME: **ANAND SYSTEM ENGINEERING PVT LTD**

EMAIL ID: info@anandcontrol.in

CONTACT NO: 9137620579

TITLE: **MDT 250-34 BRAKE ASSEMBLY 2D**

SCALE: 1:1

DATE: / /

BY: / /

APPROVED: / /

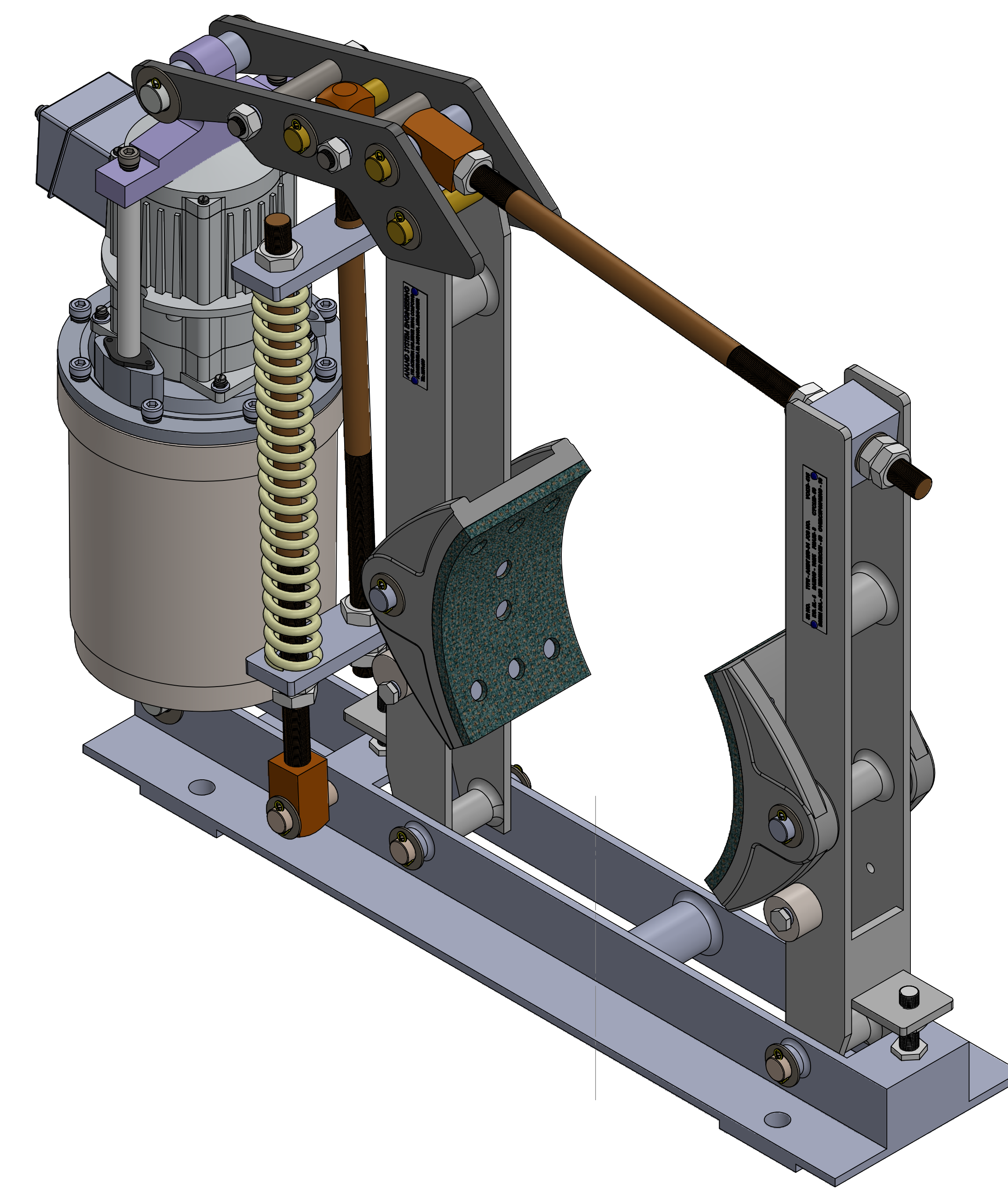
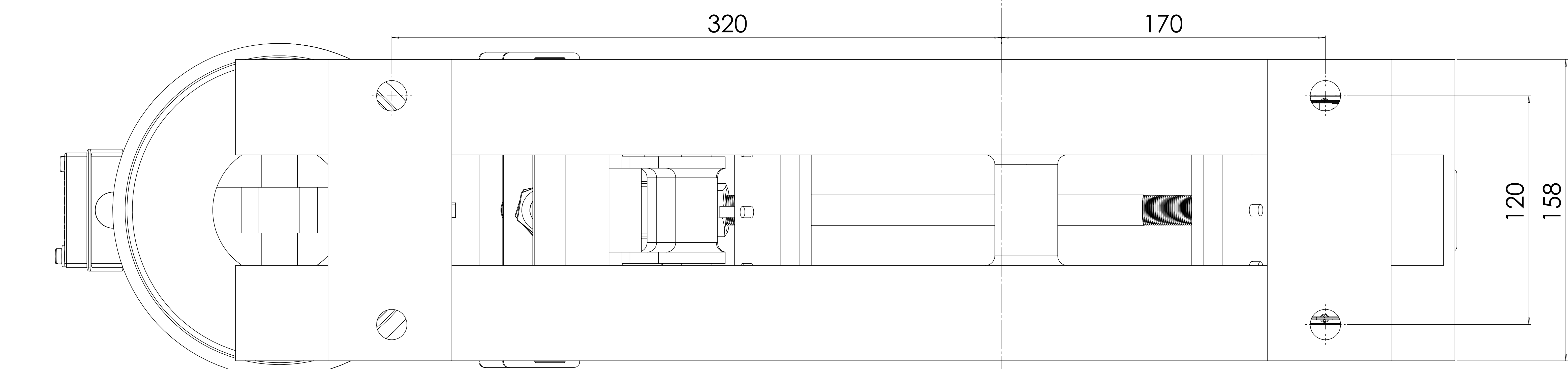
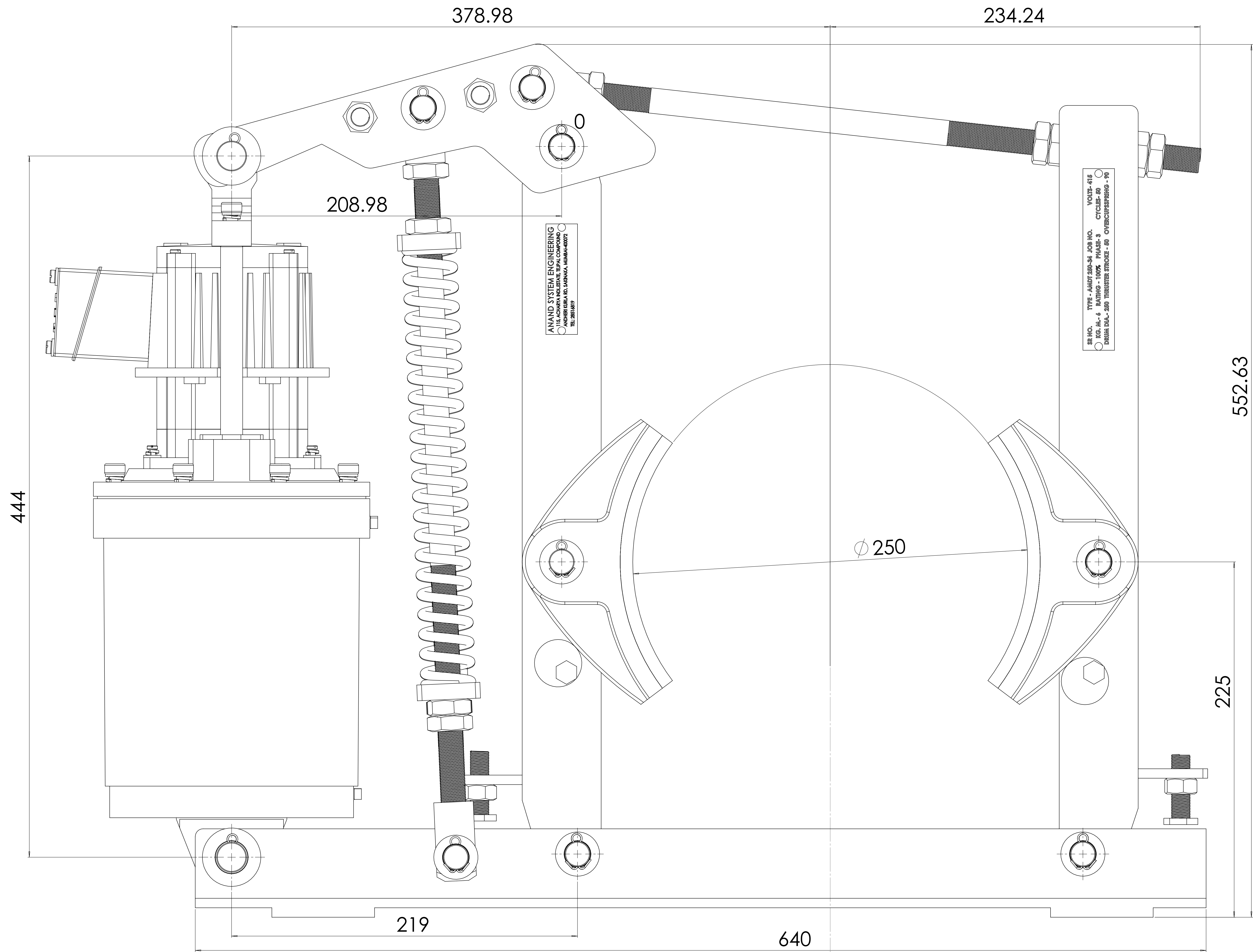

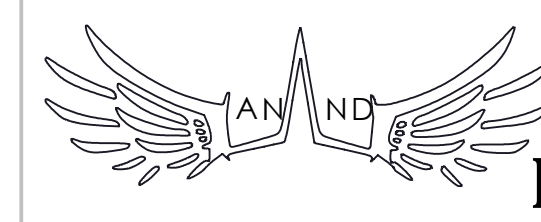
COMPANY NAME		DO NOT SCALE DRAWING		REVISION
 ANAND SYSTEM ENGINEERING PVT LTD		TITLE:		
		MDT 250-34 BRAKE ASSEMBLY 2D		
Email id: info@anandcontrol.in		DWG NO:		
CONTACT NO: 9137620579		DATE:		SIGNATURE
		SCALE: 1:1		SHEET 2 OF 2