

ITEM NO.	PART NUMBER	DESCRIPTION	MATERIAL	QTY.
1	BASE PIN.	10X80MM	M.S.	2
2	BASE	L-470 X 40	M.S.	1
3	BRAKE LINER.	THK-6.35X70	ASBESTOS	2
4	BRAKE SHOE.	150X 70	C.I.	2
5	SPRING	COMPRESS SPRING INNER 3MM COIL, 26X100X14 TURNS	SPRING STEEL	1
6	SPRING	COMPRESS SPRING OUTER 3MM COIL, 35X 100X 14 TURNS	SPRING STEEL	1
7	HEX BOLT	M 10, 8X30	M.S.	2
8	HEX BOLT M8	M 8, 10X40	M.S.	2
9	LEVER.. SLDPRT	THK-7MM, THRUSTER HOLE 13MM, 3 HOLES DIA 9.8MM, SPACER PIN HOLE-13MM	M.S.	2
10	LUG THREADING.	M10 TAP, SQ19X19, HOLE 10MM FREE	M.S.	2
11	MAIN ARM.	300X38	M.S.	1
12	AL SHOE RIVET 160	15X6	ALUMINIUM	8
13	18KK THRUSTER.	18KG THRUSTER ASSEMBLY	-	1
14	PLAIN WASHER	19X10.5X1.5	M.S.	19
15	PLAIN WASHER	25X13.5X1.5	M.S.	4
16	SHOE PIN	10X85	M.S.	2
17	SHOE SUPPORT	30X20	M.S.	2
18	SIDE ARM.	325X38	M.S.	1
19	SPACER PIN	13X80, MIDDLE 40MM, M10	M.S.	1
20	SPRING CAP.	47X14X7.5	M.S.	2
21	THRUSTER PIN	12.7X70	M.S.	2
22	TIE ROD. 1	L-200 X 10MM	M.S.	1
23	TIE ROD. 2	L-260 X 10MM	M.S.	1
24	LEVER PIN.	10X65	M.S.	3
25	HEX NUT	M10	M.S.	13
26	NAME PLATE	115X20	ALUMINIUM	1
27	NAME PLATE	70X20	ALUMINIUM	1
28	NAME PLATE RIVET 2	L-4.5 MM	AB 4	4
29	SPRING WASHER	M10	SPRING STEEL	2
30	SPRING WASHER	M8	SPRING STEEL	2
31	COTTER PIN 1-8" X 3-4" 150	1/8" X 3/4"	M.S.	14
32	COTTER PIN 1-8" X 1" 150	1/8" X 1"	M.S.	4

COMPANY NAME

**ANAND SYSTEM
 ENGINEERING PVT LTD**

TITLE:
**150-18 BRAKE
 ASSEMBLY**

Email id: info@anandcontrol.in
 CONTACT NO: 9137620579

ENG NO:
 DATE: _____
 SCALE: 1:1
 SHEET 1 OF 2

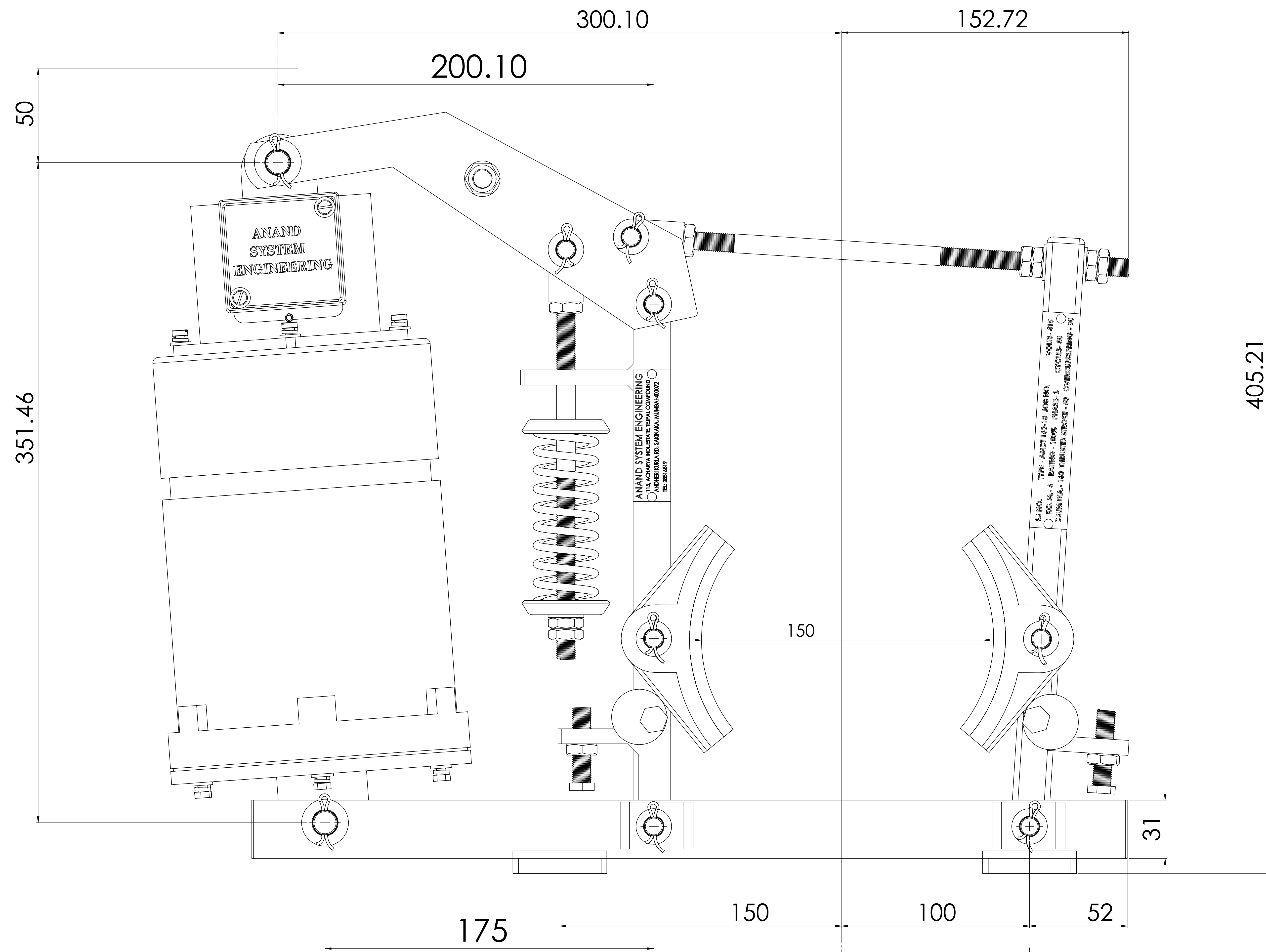

405.21

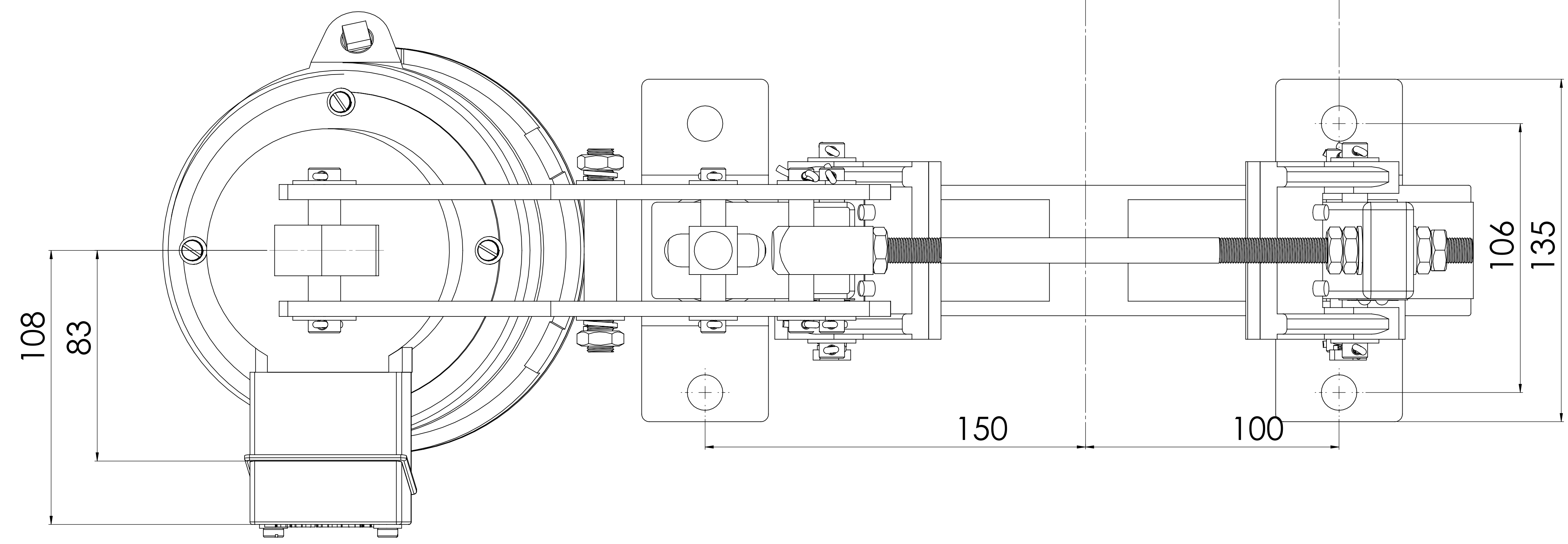
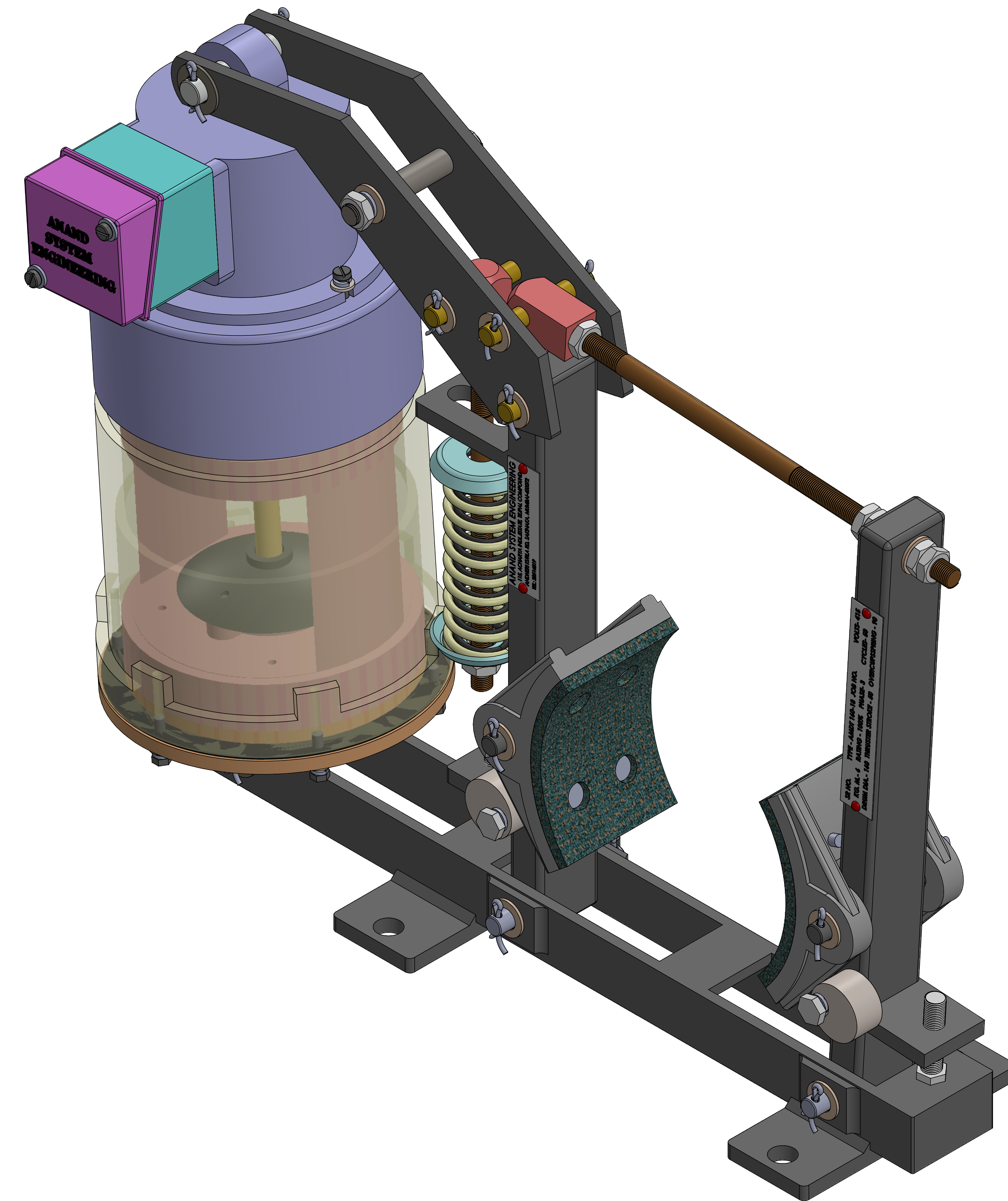

COMPANY NAME  ANAND SYSTEM ENGINEERING PVT LTD		DO NOT SCALE DRAWING REVISION
Email id: info@anandcontrol.in CONTACT NO: 9137620579		TITLE: 150-18 KG BRAKE ASSEMBLY 2D
DATE	SCALE	SHEET NO. 2 OF 2