

ITEM NO.	PART NUMBER	DESCRIPTION	MATERIAL	QTY.
1	BASE	L-415x40	M.S.	1
2	BASE PIN	65X10	M.S.	2
3	BRAKE LINER	6.35X10	ASBESTOS	2
4	BRAKE SHOE	100X70	M.S.	2
5	SPRING	COMPRESS SPRING INNER	SPRING STEEL	1
6	SPRING	COMPRESS SPRING OUTER	SPRING STEEL	1
7	HEX BOLT	M10, 40MM	M.S.	2
8	HEX BOLT	M8, 30MM	M.S.	2
9	HEX NUT	M10 G.I.	M.S.	12
10	LEVER	THK-7MM, THRUSTER HOLE 13MM, 3 HOLES DIA 9.8MM, SPACER PIN HOLE-13MM	M.S.	2
11	LEVER PIN	10X55	M.S.	3
12	LUG THREADING	M10 TAP, SQ19X19, HOLE 10MM FREE	M.S.	2
13	MAIN ARM	300X25	M.S.	1
14	NAME PLATE	115X20	ALUMINIUM	1
15	NAME PLATE	70X20	ALUMINIUM	1
16	PLAIN WASHER	25X13.5X1.5	M.S.	4
17	SHOE PIN	10X85	M.S.	2
18	SHOE SUPPORT	30X20	M.S.	2
19	SIDE ARM	327X25	M.S.	1
20	SPACER PIN	13X70, MIDDLE 30, M10	M.S.	1
21	SPRING CAP	47X17X7.5	M.S.	2
22	SPRING WASHER	M10	SPRING STEEL	2
23	SPRING WASHER	M8	SPRING STEEL	2
24	THRUSTER PIN	12.7X60	M.S.	2
25	TIE ROD	L-200 X 10MM	M.S.	2
26	PLAIN WASHER	19X10.5X1.5	M.S.	17
27	AL SHOE RIVET	6X15	M.S.	8
28	NAME PLATE RIVET	L-4.5 MM	AB 4	4
29	18KG THRUSTER 100-18	18KG THRUSTER ASSEMBLY	-	1
30	COTTER PIN 1-8" X 1" 100	1/8" X 1"	M.S.	2
31	COTTER PIN 1-8" X 3/4" 100	1/8" X 3/4"	M.S.	16

COMPANY NAME

ANAND SYSTEM ENGINEERING PVT LTD

DO NOT SCALE DRAWING

REVISION

TITLE:

MDT 100-18KG BRAKE ASSEMBLY IN 2D

Email id: info@anandcontrol.in

CONTACT NO: 9137620579

SCALE: 1:2

SHEET 1 OF 2

A1

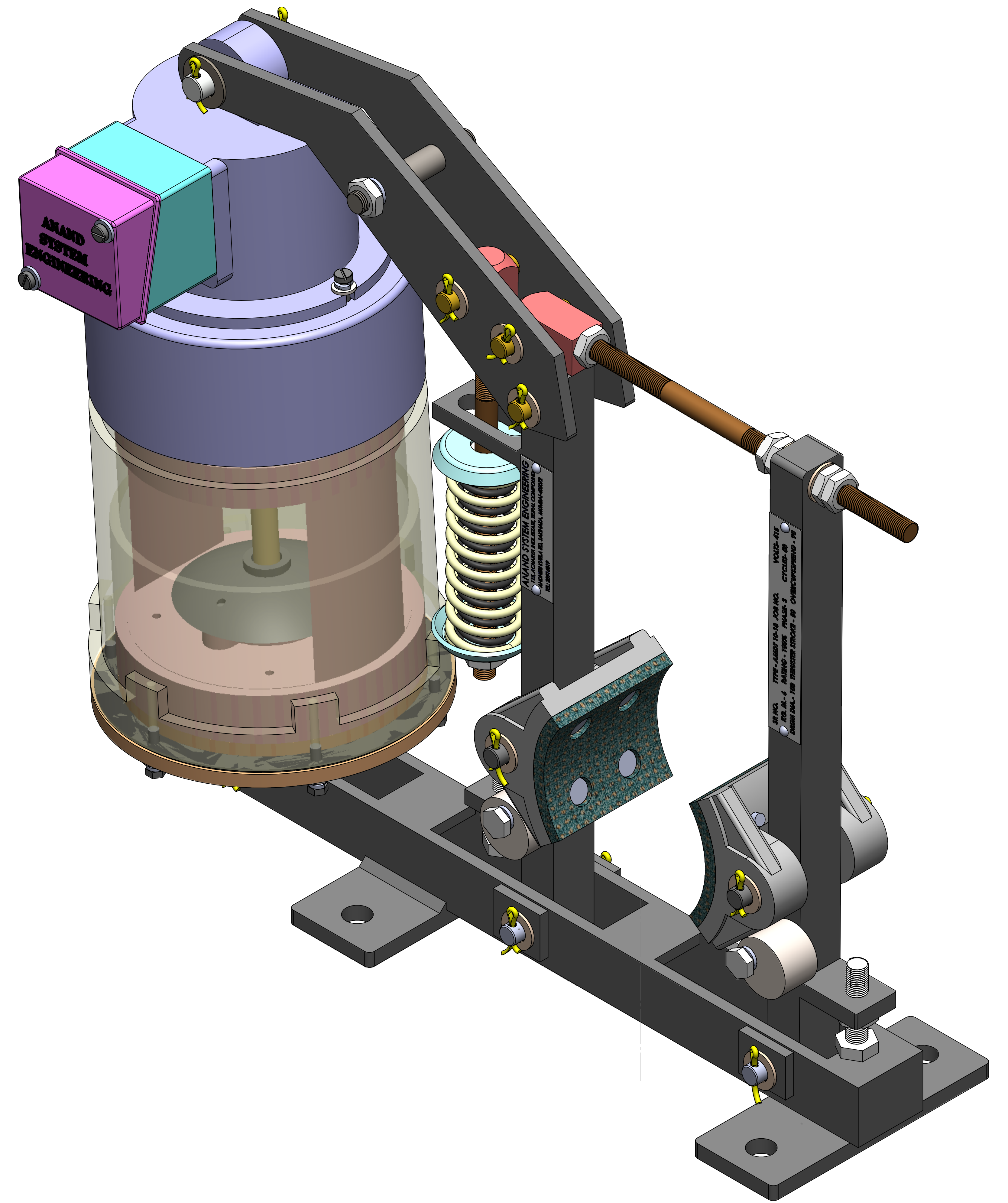
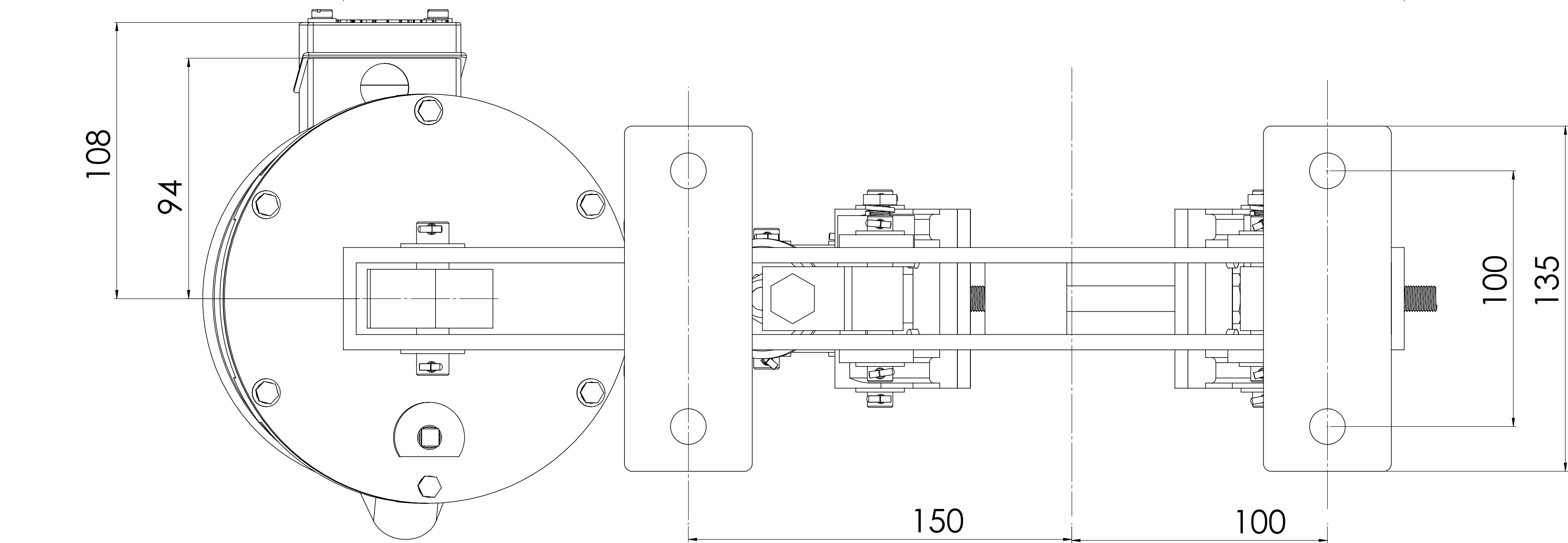
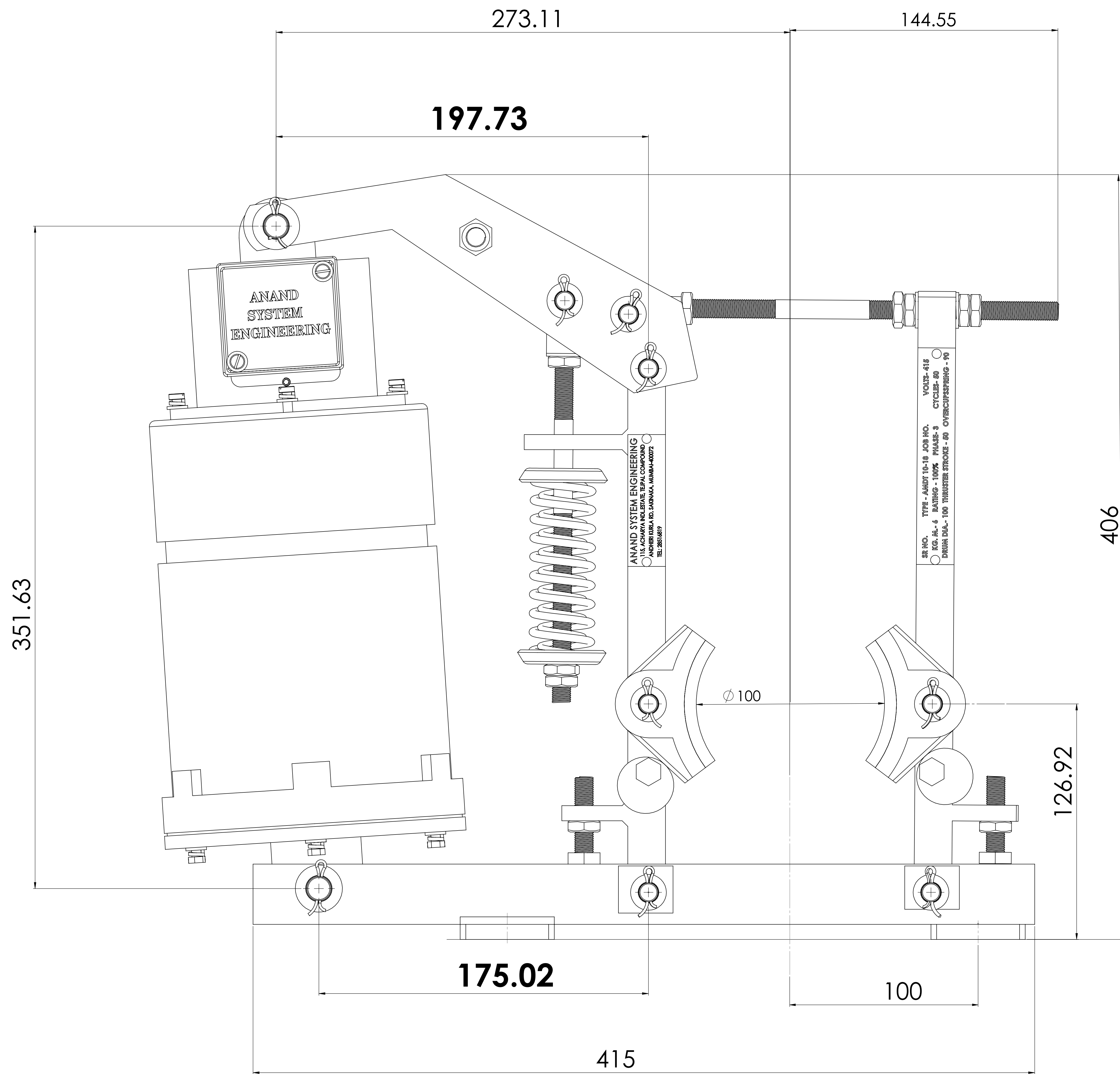

COMPANY NAME		DO NOT SCALE DRAWING	REVISION
 ANAND SYSTEM ENGINEERING PVT LTD		TITLE:	
		MDT 100-18 KG BRAKE ASSEMBLY IN 2D	
Email id: info@anandcontrol.in		CONTACT NO: 9137620579	
DWG NO.		SCALE: 1:1	
A0		SHEET 01 OF 2	