

EXPLODED VIEW

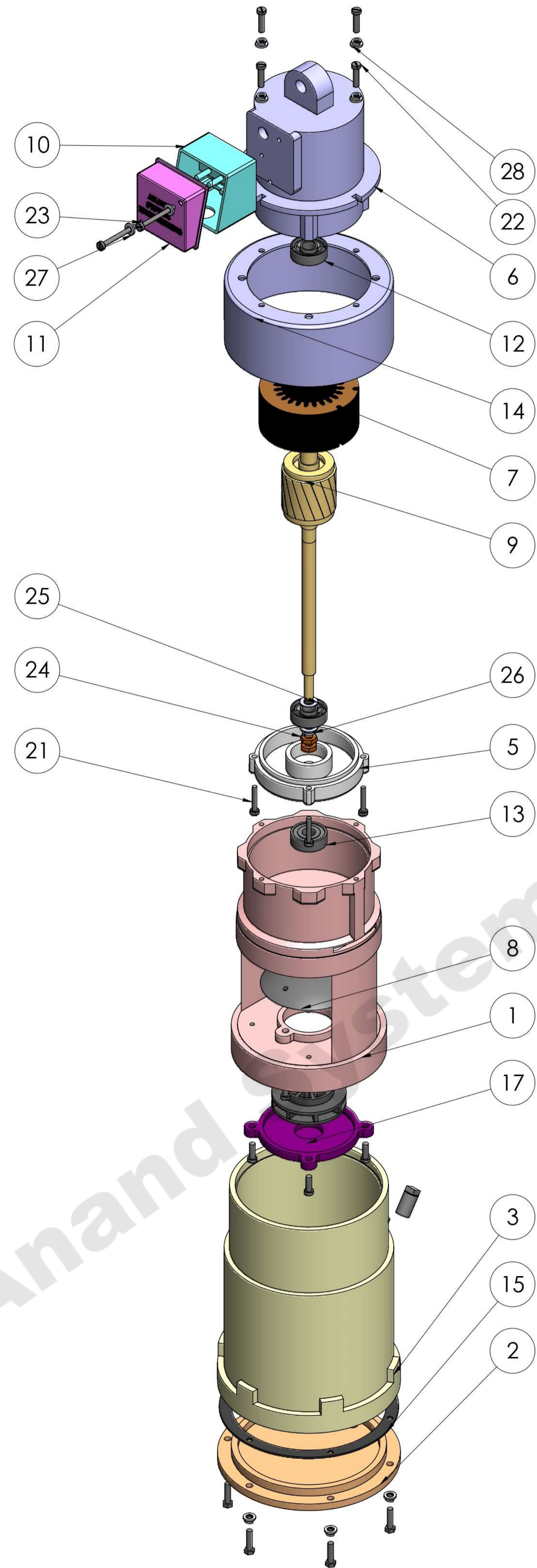

ITEM NO.	PART NUMBER & NUMBER	DESCRIPTION	MATERIAL	QTY.
1	AL SLEEVE	1.5 KG O.D-136MM,I.D-121MM,I.D2-46,H-210	ALUMINIUM	1
2	C.I. TANK END COVER	DIA -61, 6 HOLE 6.5MM, PCD 145MM	CAST IRON	1
3	C.I. TANK	161X136X210	CAST IRON	1
4	IMPELLER	65X8	THERMOPLASTIC	1
5	MOTOR HOUSING COVER	95X80X19.5	ALUMINIUM	1
6	MOTOR HOUSING		ALUMINIUM	1
7	MOTOR	WATT90AT 415V 3PHASE 50C/S,RPM 960	CAST IRON	1
8	OIL GAURD	85, 2 HOLES OF 4MM PCD 65	THERMOPLASTIC	1
9	ROTOR	L-284	CAST IRON	1
10	TERMINAL BOX	78X78, HOLES 68X68	THERMOPLASTIC	1
11	TERMINAL BOX COVER	78X78, HOLES 68X68	THERMOPLASTIC	1
12	BEARING	6201, 12X32	C.S.	2
13	OIL SEAL	32X12	RUBBER	1
14	COWL	145, 8 HOLES OF 5MM, PCD-117	PLASTIC	1
15	GASKET FOR C.I.TANK	187X135X1.5, PCD-157	RUBBER	1
16	IMPELLER COVER AND TERMINAL SCREW	5X15	M.S.	4
17	IMPELLER COVER	89X7.5, PCD 98	THERMOPLASTIC	1
18	OIL PLUG 1-8	13X20	M.S.	1
19	OIL PLUG 1-4	9.5X17	M.S.	1
20	HEX BOLT END COVER (MOTOR GUIDE)	5X20	M.S.	6
21	MOTOR HOUSING CH SCREW	4X25	M.S.	4
22	OIL GAURD SCREW	5X20	M.S.	6
23	TERMINAL BOX COVER FIXING SCREW CHZ	4X40	M.S.	2
24	LOCK NUT	5/16", ID 7MM	M.S.	2
25	PLAIN WASHER	16X8.5X1	M.S.	2
26	SPRING WASHER	A8	SPRING STEEL	1
27	PLAIN WASHER	11X4.5X1.5	M.S.	2
28	PLAIN WASHER	11X5X1.5	M.S.	10
29	SPRING WASHER A5	A5	SPRING STEEL	10
30	GRAB SCREW	5X5	M.S.	1
31	RIVET FOR NAME PLATE	AB4, L-4.5	M.S.	4
32	NAME PLATE	61X43	ALUMINIUM	1
33	CABLE PLUG	1.5	M.S.	3
34	KEY FOR MOTOR SHAFT	DIA-13, 4MM	M.S.	1

DO NOT SCALE DRAWING

REVISION

TITLE: **18KG THRUSTER ASSEMBLY**

DIVG NO.

DATE

SIGNATURE

SCALE: 1:10

SHEET 1 OF 2

NAME: **ANAND SYSTEM ENGINEERING PVT LTD**

Email id: info@anandcontrol.in

CONTACT NO: 9137620579

DATE

SIGNATURE

SCALE: 1:10

SHEET 1 OF 2

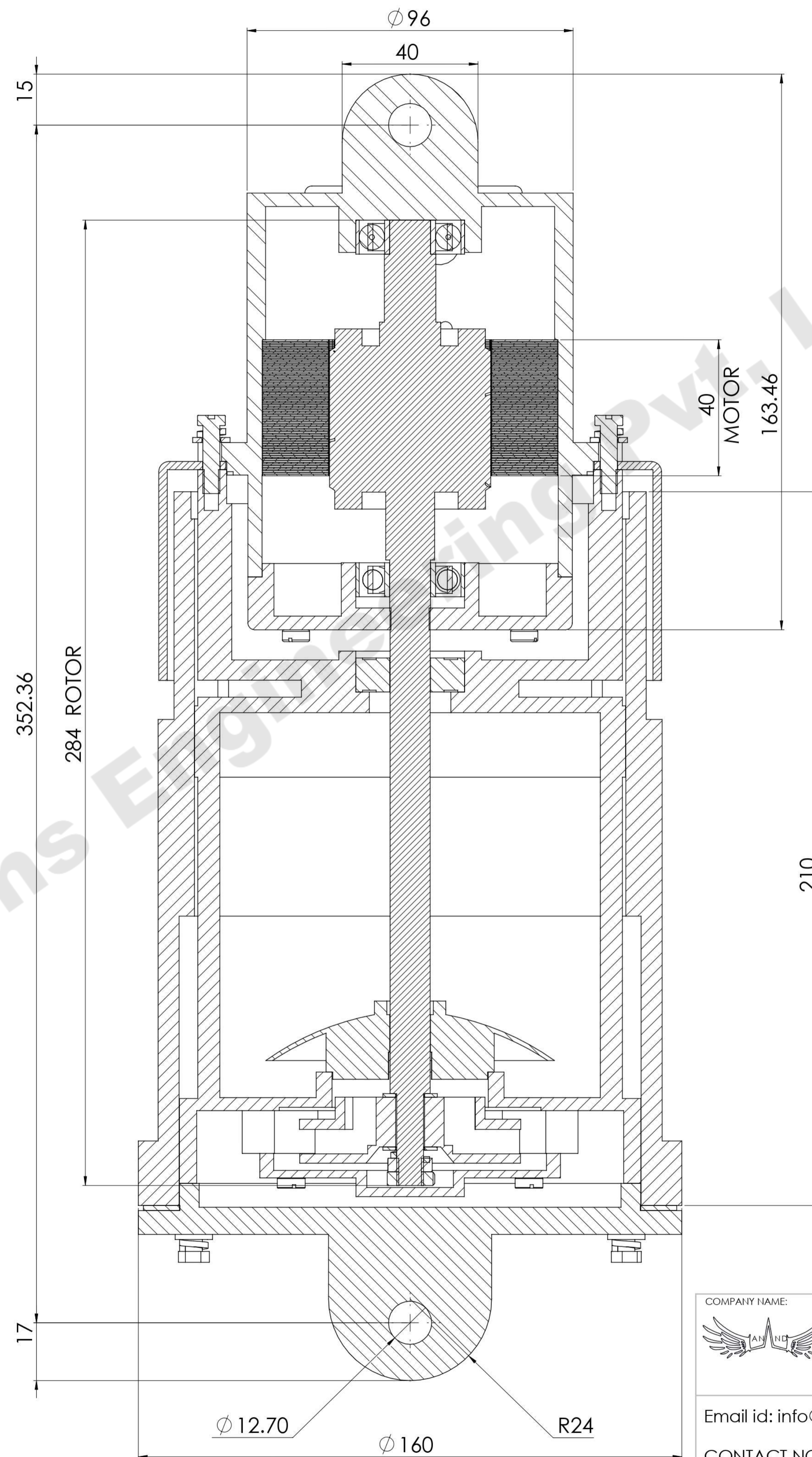
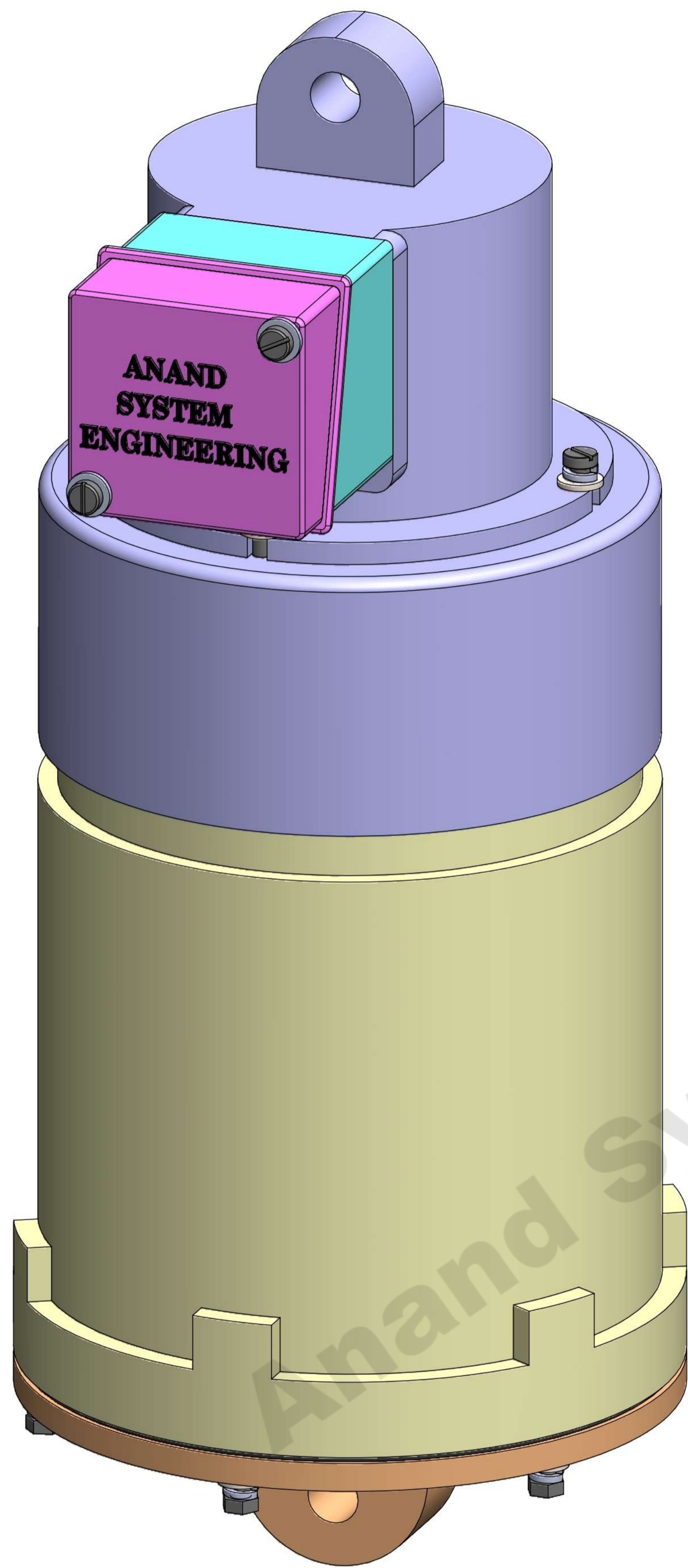

COMPANY NAME: **ANAND SYSTEM ENGINEERING PVT LTD**

Email id: info@anandcontrol.in

CONTACT NO: 9137620579

DO NOT SCALE DRAWING	REVISION
TITLE: 18KG THRUSTER ASSEMBLY	
DATE	SIGNATURE
DIVG NO.	A1
SCALE: 1:10	SHEET 2 OF 2

SECTION C-C
SCALE 1 : 0.8