

4

3

2

1

F

F

GALVANIZE
STEEL

PVC SLEEVE

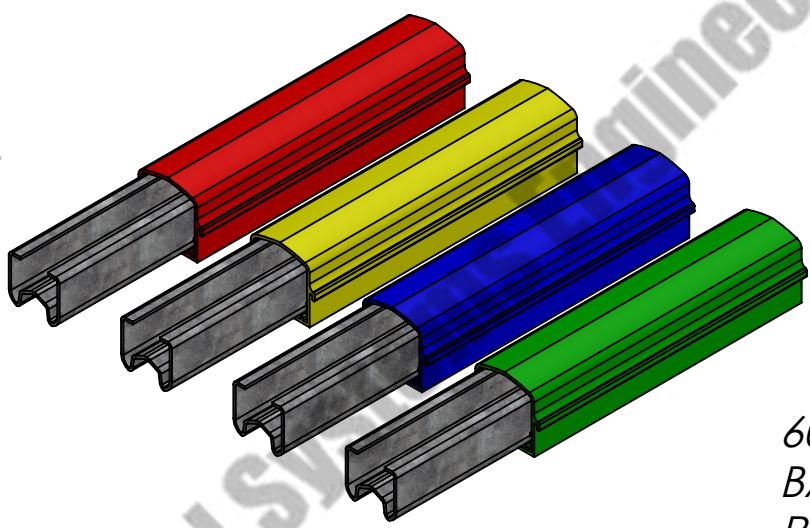
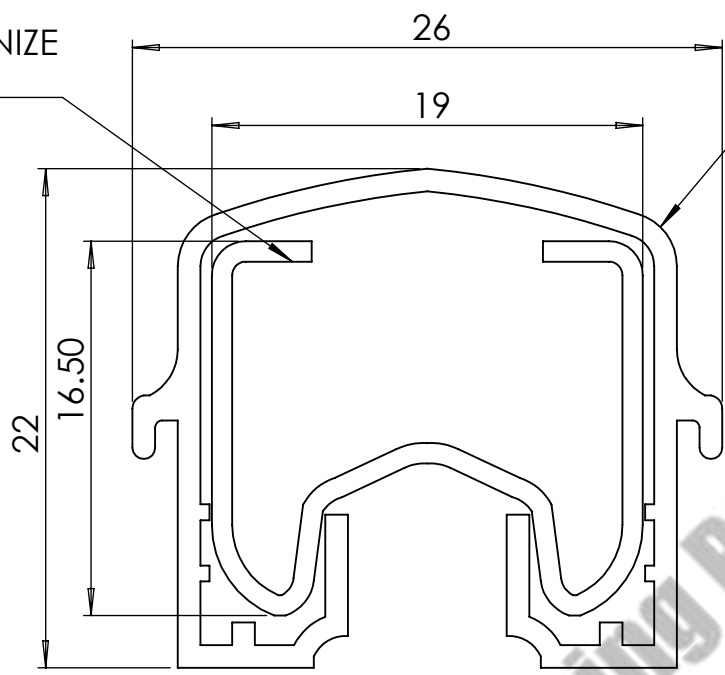

60AMP- GALVANIZE- 04
 BAR BOLTED(W) TYPE
 RED YELLOW BLUE GREEN
 COLOUR PVC

B

B

COMPANY NAME:



ANAND SYSTEM
 ENGINEERING PVT LTD

DO NOT SCALE DRAWING.

REVISION:

TITLE:

Safelink W
 60Amp GI RYBG
 2D

Email id: info@anandcontrol.in

CONTACT NO: 9137620579

FINISH:

DWG NO.

DATE:

SIGNATURE:

A

A

DRAWN	SAURABH	MATERIAL:	
CHK'D			
APP'D			
MFG		WEIGHT:	

SCALE:

SHEET: 1 OF 1

4

3

2

1

ITEM NO.	PART NAME	DESCRIPTION	MATERIAL	QTY.
1	4 POLE HANGER CLAMP W TYPE.ASSEMBLY	158X29X20	DELTRIN	4
	4 POLE HANGER CLAMP CC	158X29X20	DELTRIN	1
	HEX BOLT	M8, 8X20, END COVER FIXING	M.S.	2
	PLAIN WASHER	19X8.5X1.5	M.S.	2
	HEX NUT	M6	M.S.	2
	SPRING WASHER	M8	SPRING STEEL 4454 GRADE-02	2
2	BUSBAR ASSEMBLY W TYPE	40X40X400, THK-5 MM		4
	AL-W-type	4500X19X16.5	ALUMINIUM	1
	SLEEVE W TYPE	4415X26X22	PVC	1
3	Web-Bracket W TYPE	35X35, THK-5 MM	M.S.	6
	JOINT CLAMP ASSEMBLY W TYPE	70X28X40	G.I	8
4	HEX NUT	M6	M.S.	4
	PLAIN WASHER	M8	M.S.	4
	POWERFEED CLAMP W-TYPE	16.3X22X81	ALUMINIUM	1
	SPRING WASHER M6 W TYPE	M6	SPRING STEEL 4454 GRADE-02	4
	SQUARE HEAD BOLT W- TYPE	18XM6	M.S.	4
	JOINT COVER W-TYPE	42X26X102	DELTRIN	8
5	ANCHOR CLAMP ASSEMBLY W TYPW	28X30X20	DELTRIN	4
	ANCHOR CLAMP W TYPE		DELTRIN	2
	HEX_BOLT	M8X25	M.S.	1
	HEX NUT	M8	M.S.	1
6	PLAIN WASHER	M8	M.S.	1
	SPRING WASHER	M8	SPRING STEEL 4454 GRADE-02	1
	HEX BOLT	M5X35	M.S.	1
	LOCK NUT	M5	M.S.	1
7	CENTER POWERFEED ASSEMBLY W-TYPE	219X105.6X37		4
	CENTER POWERFEED W-TYPE-1		DELTRIN	2
	NUT	M8	M.S.	2
	PAN HEADED SCREW	SELF THREAD SCREW	M.S.	3
	PAN HEADED SCREW	SELF THREAD SCREW	M.S.	2
	PLAIN WASHER W TYPE	18.5X9X1.5	M.S.	6
	POWER FEED ALU BRACKET	144X37X5.5	ALUMINIUM	1
	GRUMET	Ø 30	RUBBER	2
	POWERFEED CLAMP W-TYPE	16.3X22X81	ALUMINIUM	1
	SPRING WASHER	M8	SPRING STEEL 4454 GRADE-02	6
8	SQUARE HEAD BOLT W- TYPE	18XM6	M.S.	4
	HEX BOLT	M8, 8X20	M.S.	2
	HEX NUT	M6	M.S.	4
	SINGLE POLE HANGER CLAMP W-TYPE ASSM	28X37X19.3		4
9	SINGLE POLE HANGER CLAMP W-TYPE			1
	HEX BOLT	M8, 8X20	M.S.	1
	HEX NUT	M8	M.S.	1
	PLAIN WASHER	M8	M.S.	1
10	SPRING WASHER	M8	SPRING STEEL 4454 GRADE-02	1
	EXPANSION JOINT ASSEMBLY W-TYPE	321X80X30		4
	CLAMP EXPANSION W-TYPE			1
	END CLAM EXPANSION	16.5X23.5X22	G.I	6
	DSL_NEW-1	DSL BUSBAR WITH SLEEVE		1
	WASHER-1	18X8X1.5	M.S.	1
	COPPER SLEEVE	20X20	COPPER	4
	COPPER SLEEVE 2	20X59	COPPER	2
	PLAIN WASHER	M6	M.S.	1
	NUT	M6	M.S.	1
11	COPPER-FLAT-COIL 2 W-TYPE		COPPER	2
	COPPER-FLAT-COIL-1 W-TYPE		COPPER	2
	EXPANSION JOINT COVER W-TYPW		DELTRIN	2
	SQUARE HEAD BOLT W- TYPE	18XM6	M.S.	6
	HEX BOLT	M4X10	M.S.	4
	HEX NUT	M4	M.S.	4
	CURRENT COLLECTOR 100 AMP ASSM	230X332		4
	ARM 1	220X15.5X3	M.S.	4
	LOWER BRACKET	56X73X30	CASTING	1
	LOWER PIN	16X70	M.S.	1
12	VERTICAL LEVER CC	50X61X24	CASTING	1
	SPACER PIN	26X Ø 6	M.S.	6
	UPPER BRACKET	108.5X43X10	PLASTIC	2
	VERTICAL STUD	104X Ø 7	M.S.	1
	SHOE HOLDER	108.5X20X40	PLASTIC	1
	CONTACT PATTI	87X47X3	COPPER	1
	SPRING	Ø 13.5X22	SPRING STEEL 4454 GRADE-02	1
	LOWER BRACKET CC 2	70X30X3	M.S.	1
	HEX BOLT	8X40	M.S.	2
	NUT	M8	M.S.	2
13	PLAIN WASHER W TYPE	18.5X9X1.5	M.S.	2
	HEX NUT	M4	M.S.	2
	TENSION SPRING	Ø 15X115	SPRING STEEL 4454 GRADE-02	1
	wire	105 SQ MM, 1mtr		1
14	C.C-Bracket 100 AMP	80X60XTHK-6, SQ-25X25X400	M.S.	1
	END CLAMP ASSEMBLY W TYPE			8
	END CLAMP W TYPE			8
	SQUARE HEAD BOLT W- TYPE	18XM6	M.S.	8
15	HEX NUT	M6	M.S.	8
	SPRING WASHER M6 W TYPE	M6	SPRING STEEL 4454 GRADE-02	8
	PLAIN WASHER	M8	M.S.	8
	END POWER FEED COVER W-TYPE	112X30X35	PVC	3
15	END COVER W TYPE	73X39X30	PVC	4
	TRANSFER CAP ASSM W-TYPE			1
	HEX BOLT	M8X50	M.S.	1
	NUT	M8	M.S.	2
	PLAIN WASHER	M8	M.S.	1
	SPRING WASHER	M8	SPRING STEEL 4454 GRADE-02	1
15	TRANSFER CAP BODY W-TYPE	37.5X33.5X89.3		1
	TRANSFER CAP M.S. PLATE W-TYPE 2D.PDF	75 X36X6	M.S.	1

EXPLODED VIEW

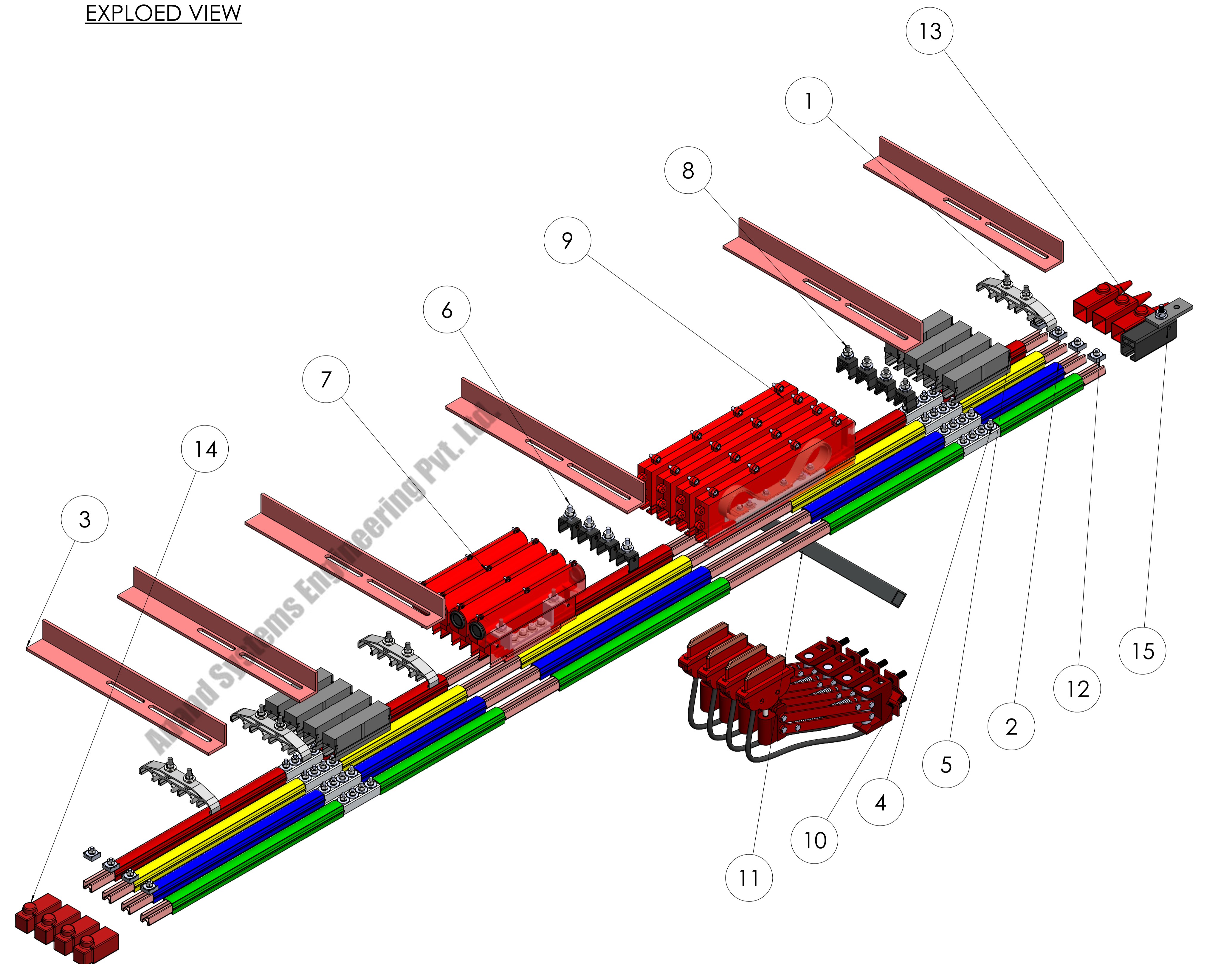

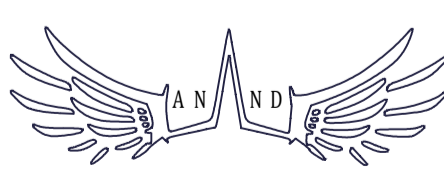
COMPANY NAME:  ANAND SYSTEM ENGINEERING PVT LTD		DO NOT SCALE DRAWING REVISION:
Email id: info@anandcontrol.in CONTACT NO: 9137620579		TITLE: W TYPE (BOLT TYPE) ASSEMBLY 2D
DWG NO:		DATE:
SCALE:		SIGNATURE:
DRAWN: SAURABH CKD: AJAY APPD: MFC:	MATERIAL:	SHEET: 1 OF 1

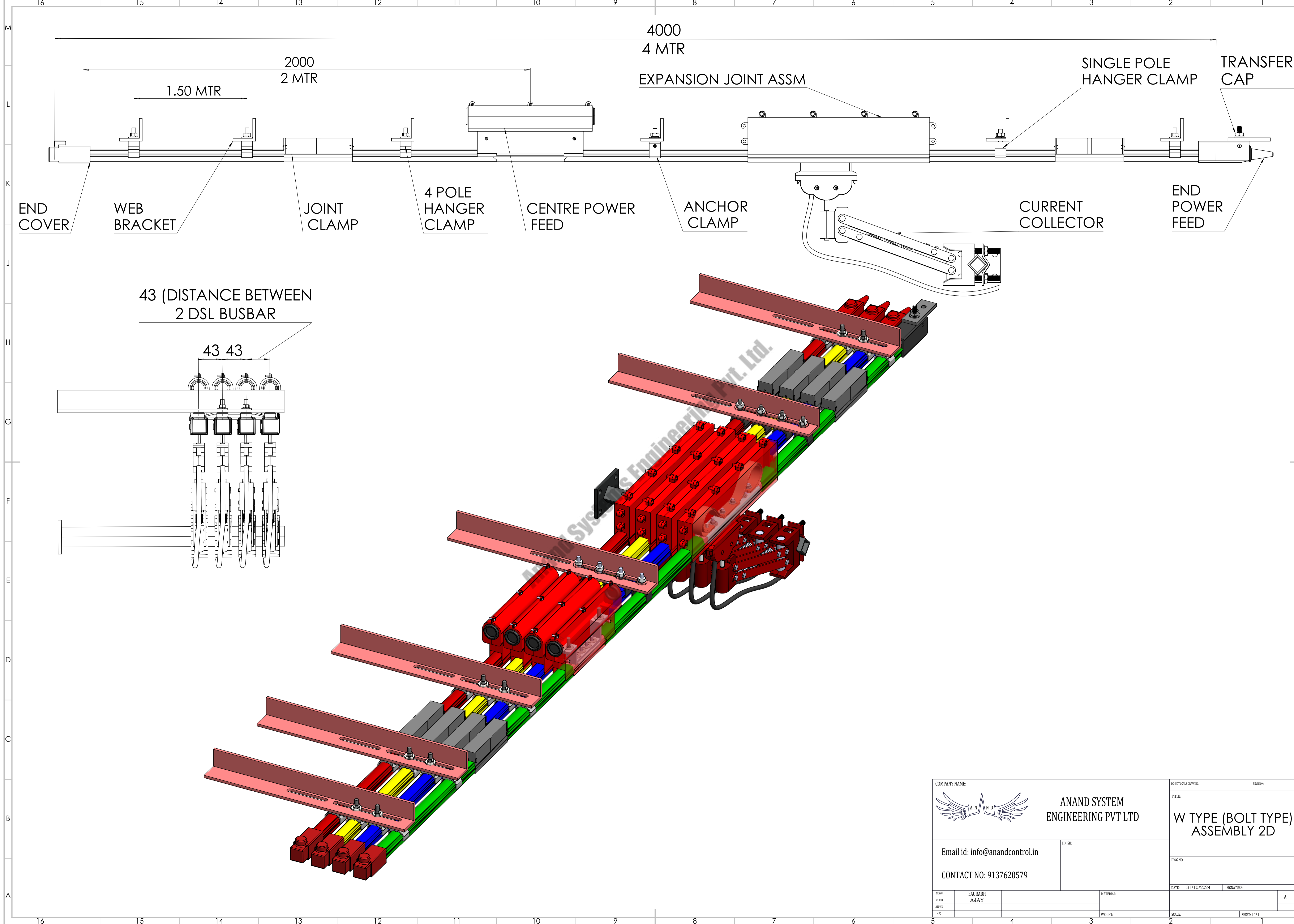

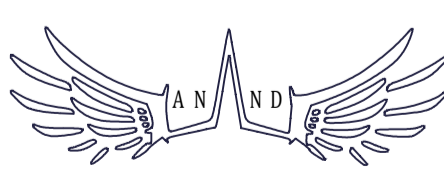
COMPANY NAME:		ANAND SYSTEM ENGINEERING PVT LTD		DO NOT SCALE DRAWING	REVISION:
		Email id: info@anandcontrol.in CONTACT NO: 9137620579		TITLE: W TYPE (BOLT TYPE) ASSEMBLY 2D	
DATE: 31/10/2024	SIGNATURE:	DWG NO:		SHEET: 1 OF 1	
DRWN: SAURABH	CHKD: AJAY	MATERIAL:	WEIGHT:	A	

4

3

2

1

F

F

E

E

D

D

C

C

B

B

A

A

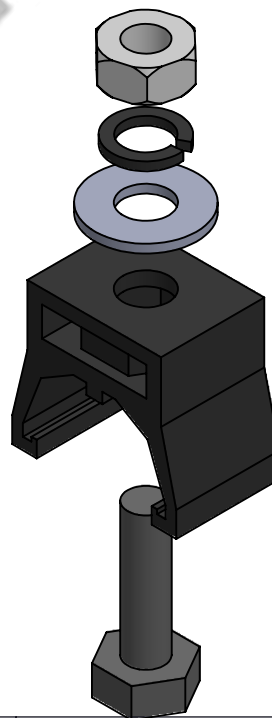
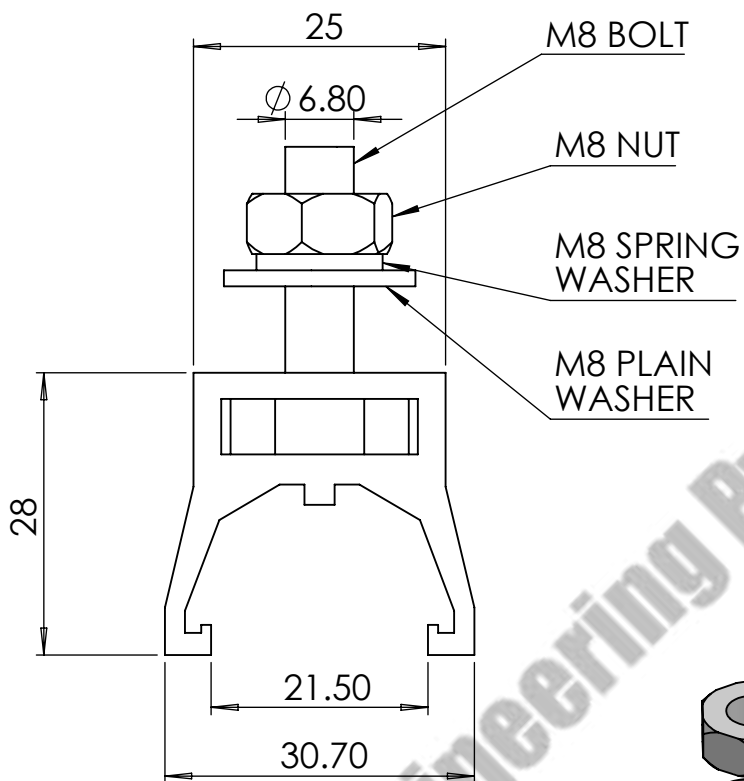

COMPANY NAME:



ANAND SYSTEM
ENGINEERING PVT LTD

DO NOT SCALE DRAWING.

REVISION:

TITLE:

SINGLE POLE
HANGER CLAMP
W-TYPE ASSM 2D

Email id: info@anandcontrol.in

CONTACT NO: 9137620579

FINISH:

DWG NO.

DATE:

SIGNATURE:

DRAWN	SAURABH
CHK'D	
APP'D	
MFG	

MATERIAL:

WEIGHT:

SCALE:

SHEET: 1 OF 1

4

3

2

1

4

3

2

1

F

F

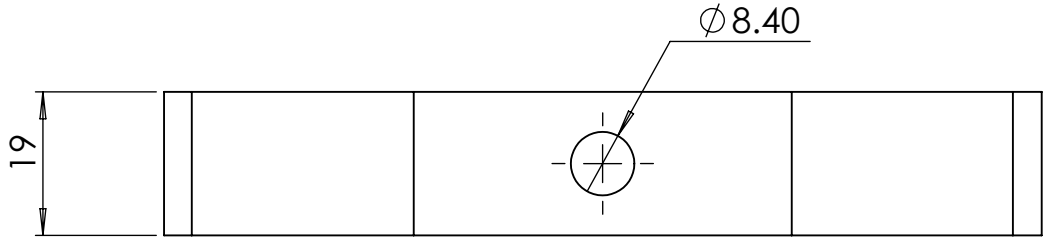

E

E

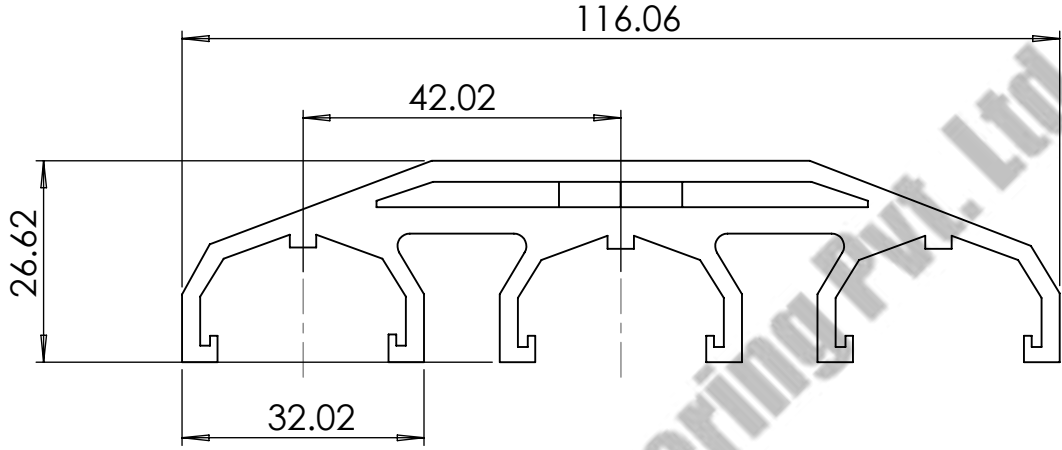

D

D

C

C

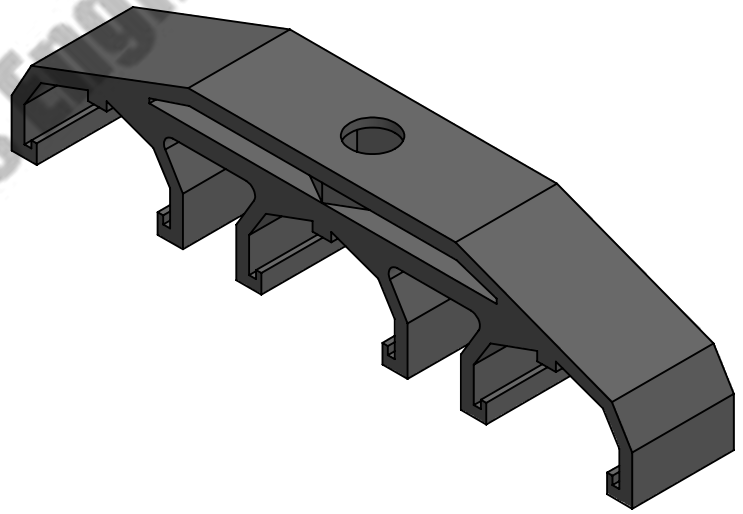

B

B

COMPANY NAME:



**ANAND SYSTEM
ENGINEERING PVT LTD**

DO NOT SCALE DRAWING.

REVISION:

TITLE:

**3 POLE HANGER
CLAMP W TYPE
2D**

Email id: info@anandcontrol.in

FINISH:

CONTACT NO: 9137620579

DWG NO.

A

A

DATE:	SIGNATURE:	A
SCALE:	SHEET: 1 OF 1	
MATERIAL:		
WEIGHT:		

4

3

2

1

4

3

2

1

F

F

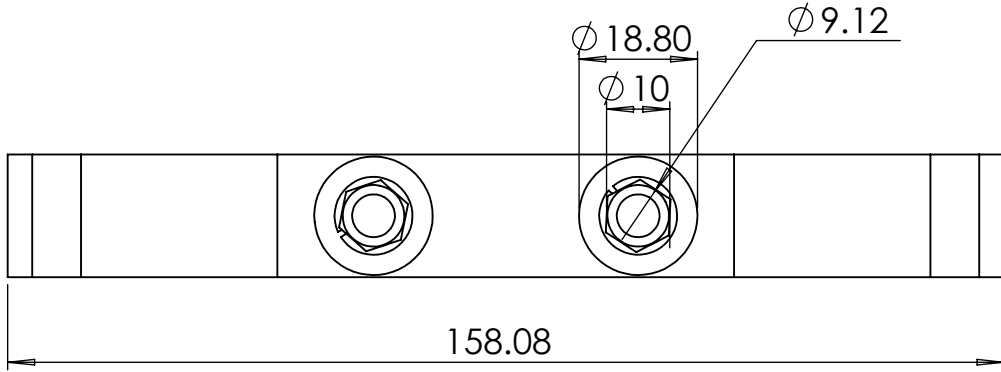

E

E

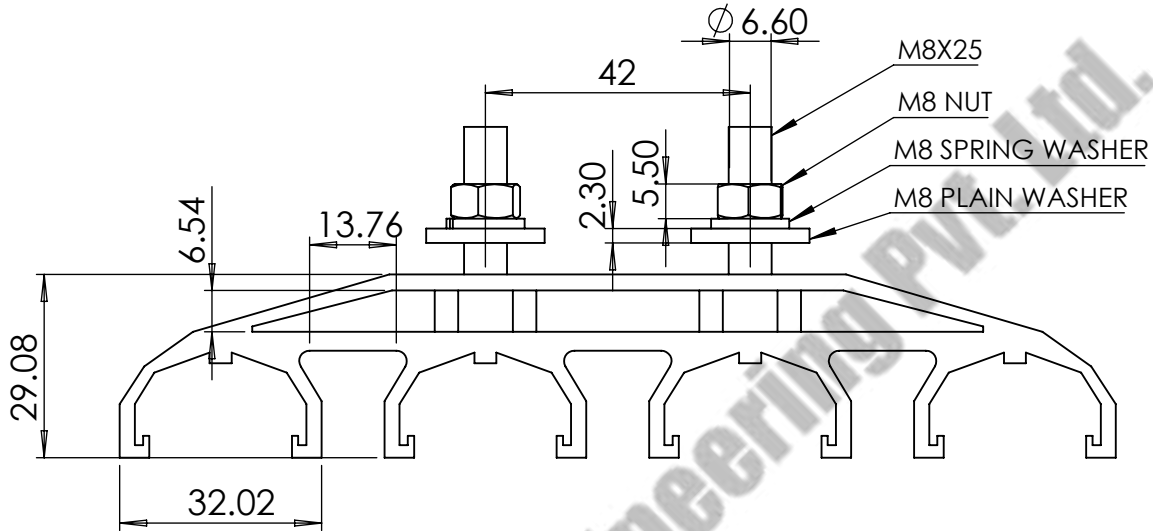

D

D

C

C

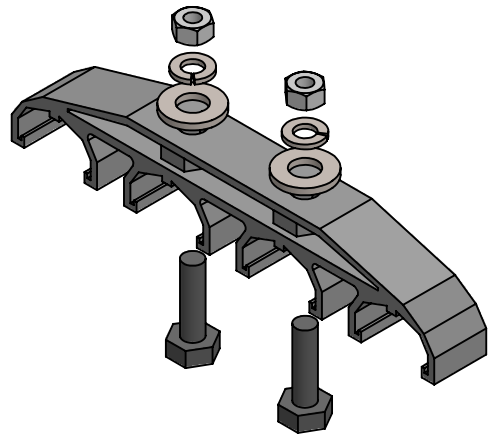

B

B

COMPANY NAME:



ANAND SYSTEM
ENGINEERING PVT LTD

DO NOT SCALE DRAWING.

REVISION:

TITLE:

4 POLE HANGER
CLAMP W
TYPE.ASSEMBLY 2D

Email id: info@anandcontrol.in

CONTACT NO: 9137620579

FINISH:

DWG NO.

DATE:

SIGNATURE:

A

A

DRAWN	SAURABH			MATERIAL:			
CHK'D							A
APP'D							
MFG				WEIGHT:		SCALE:	SHEET: 1 OF 1

4

3

2

1

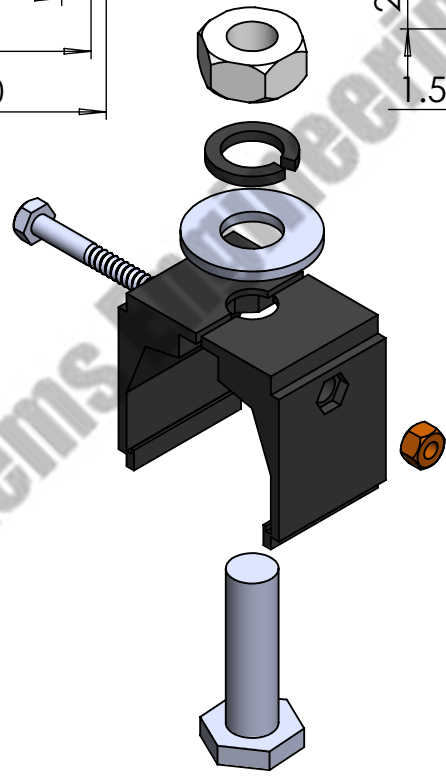
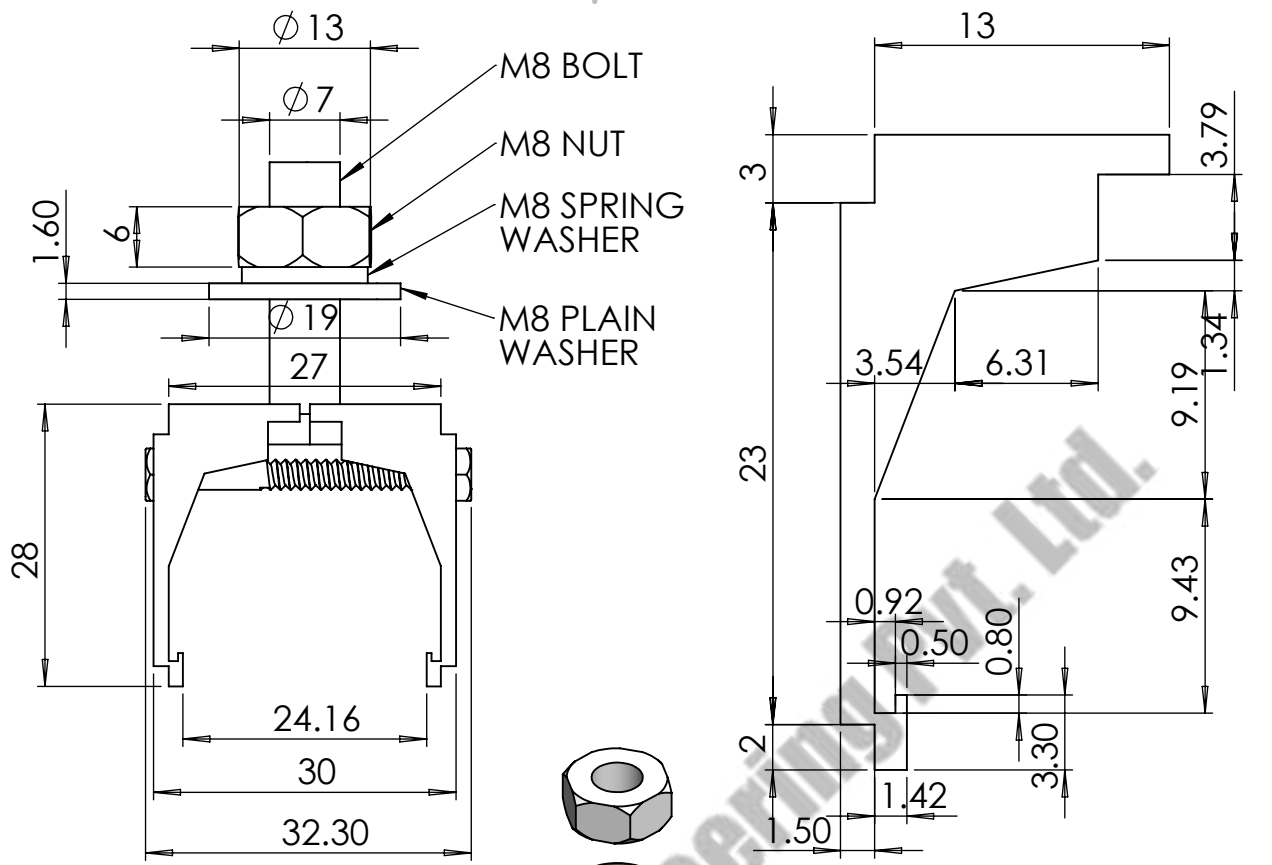

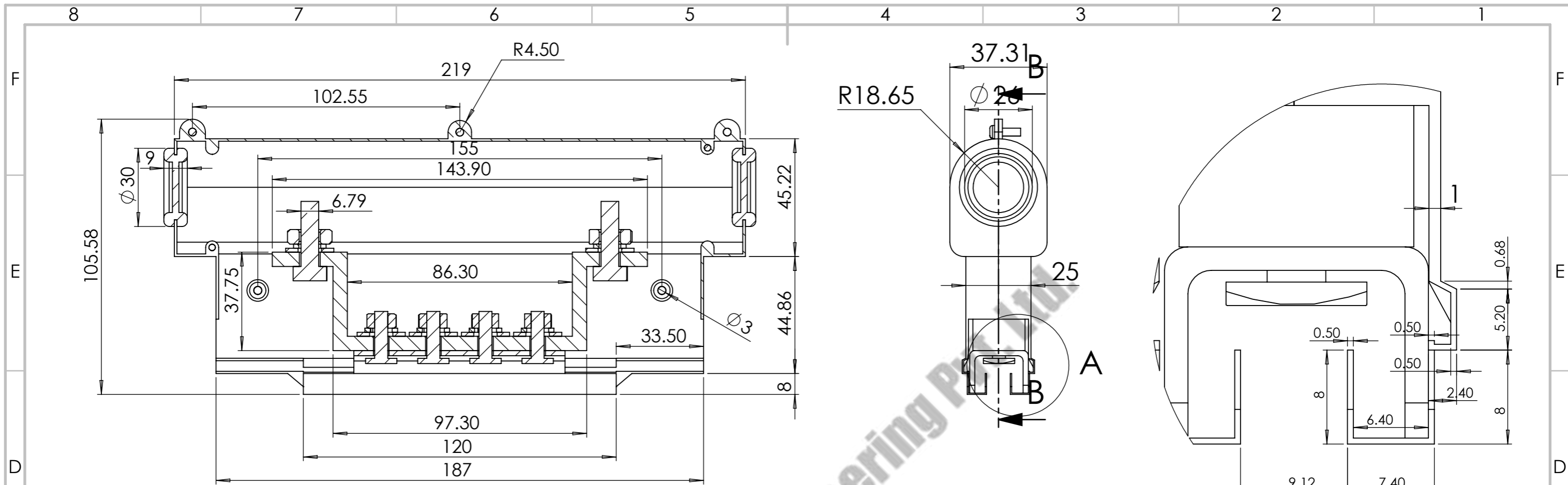

COMPANY NAME:		DO NOT SCALE DRAWING.		REVISION:																	
		ANAND SYSTEM ENGINEERING PVT LTD		TITLE: ANCHOR CLAMP ASSEMBLY W TYPE 2D																	
Email id: info@anandcontrol.in		FINISH:		DWG NO. 28X30X20																	
CONTACT NO: 9137620579				DATE: _____ SIGNATURE: _____																	
<table border="1"> <tr><td>DRAWN</td><td>SAURABH</td><td></td><td></td></tr> <tr><td>CHK'D</td><td></td><td></td><td></td></tr> <tr><td>APP'D</td><td></td><td></td><td></td></tr> <tr><td>MFG</td><td></td><td></td><td></td></tr> </table>	DRAWN	SAURABH			CHK'D				APP'D				MFG					MATERIAL:			A
DRAWN	SAURABH																				
CHK'D																					
APP'D																					
MFG																					
		WEIGHT:		SCALE:	SHEET: 1 OF 1																

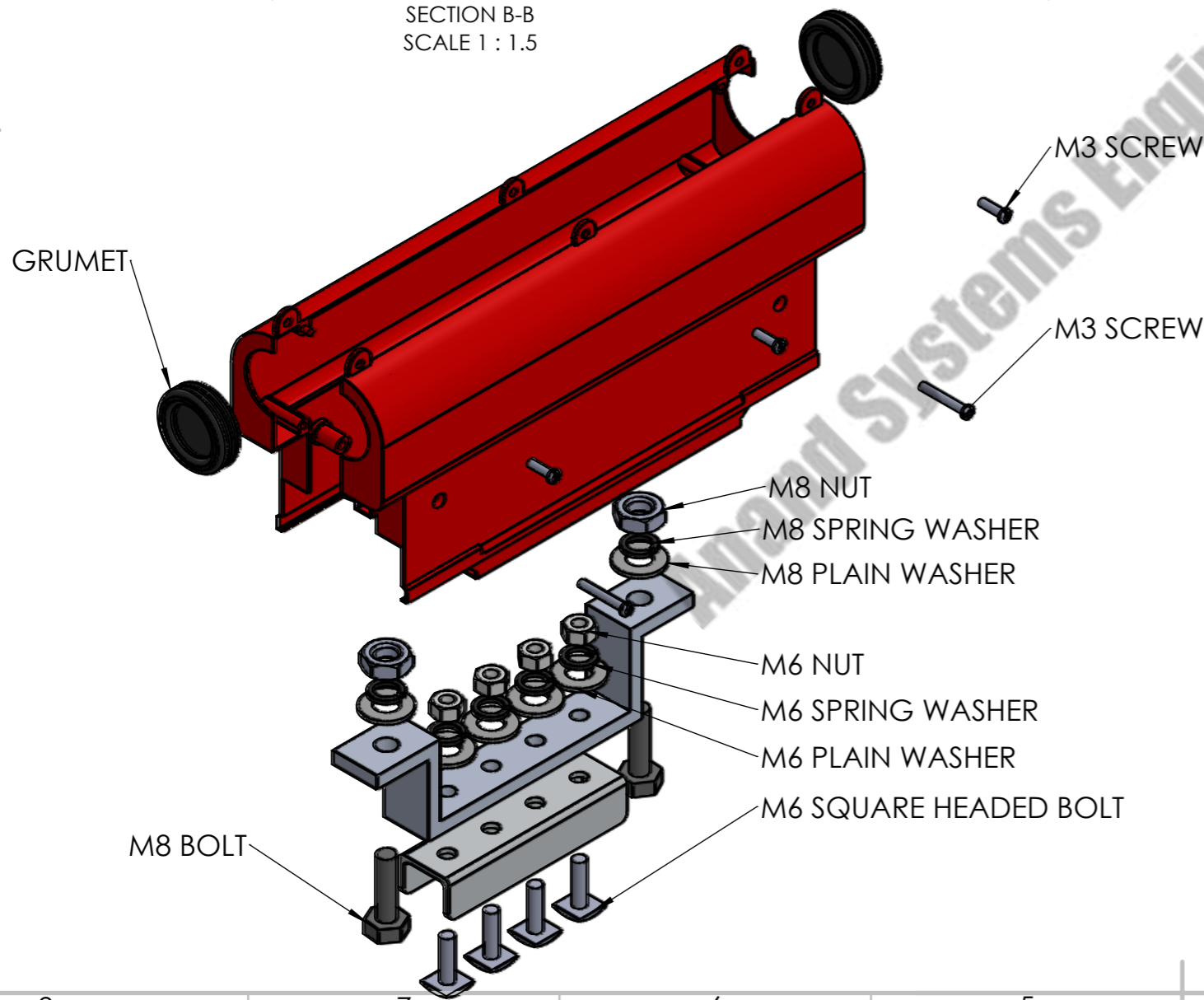

SECTION B-B
SCALE 1 : 1.5

DETAIL A
SCALE 3 : 1



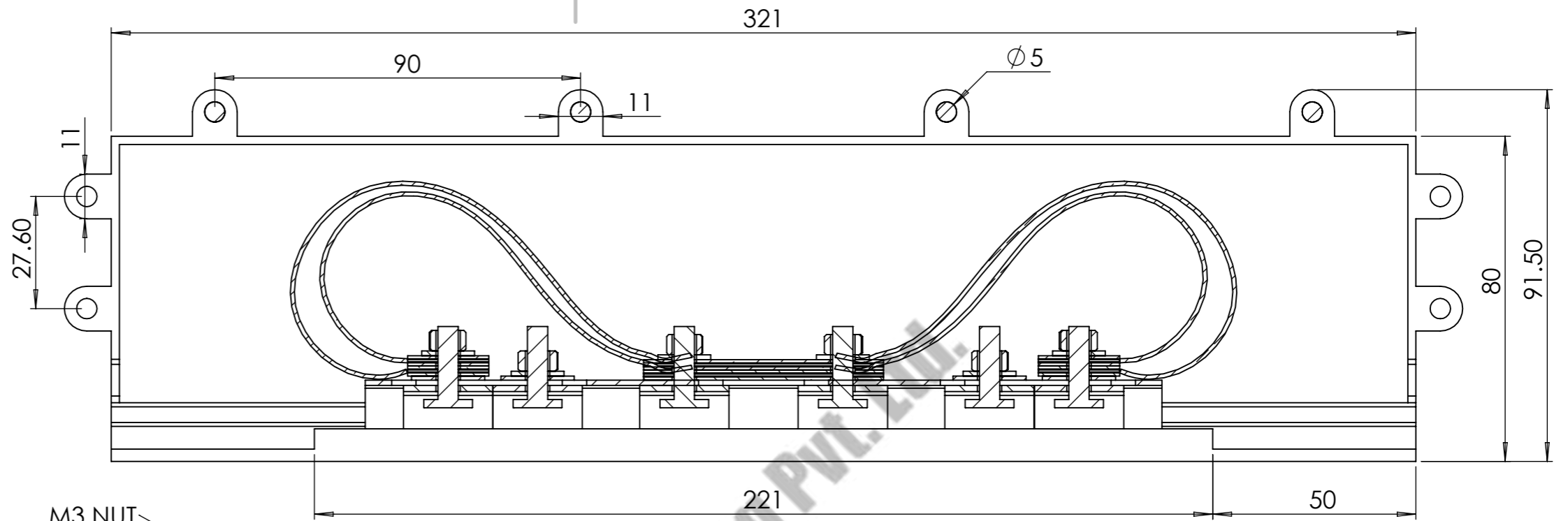
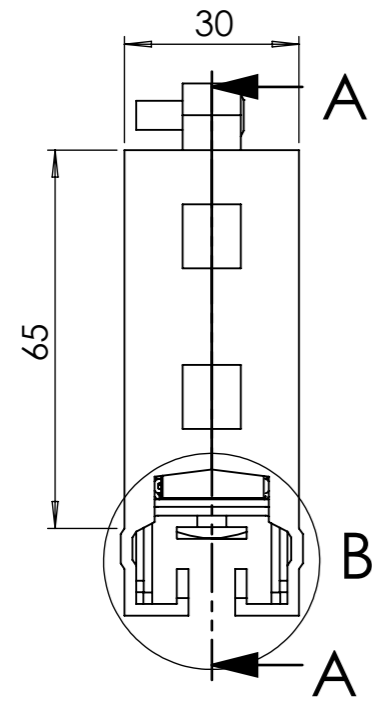

COMPANY NAME:		ANAND SYSTEM ENGINEERING PVT LTD		DO NOT SCALE DRAWING:	REVISION:
		Email id: info@anandcontrol.in CONTACT NO: 9137620579		TITLE: CENTER POWERFEED ASSEMBLY W-TYPE 2D	
FINISH:		DWG NO:		219X105.6X37	
MATERIAL:		DATE:		SIGNATURE:	
DRAWN:	SAURABH	WEIGHT:		SCALE:	
CHK'D:		SHEET: 1 OF 1		A	
APP'D:					
MFG:					

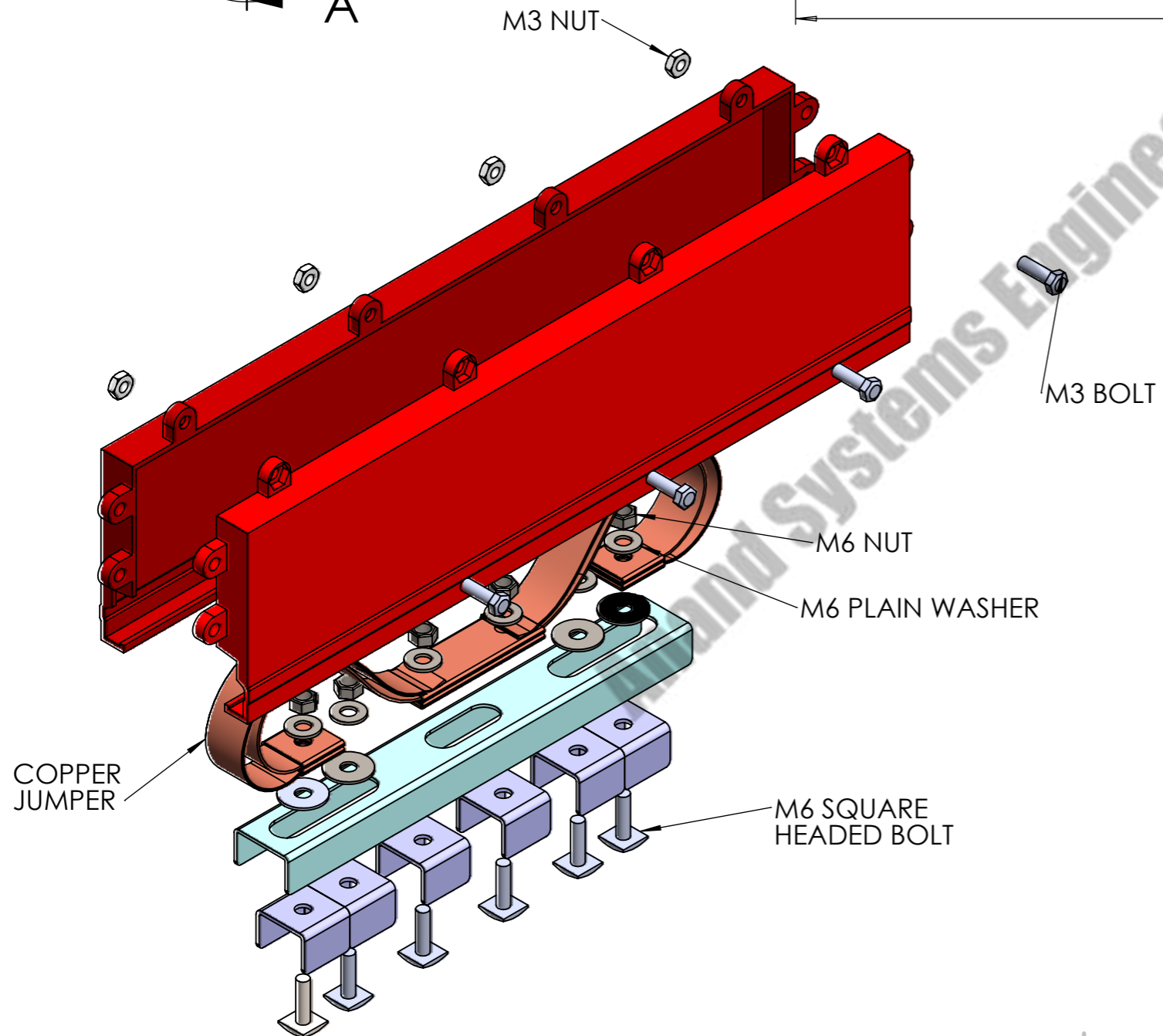
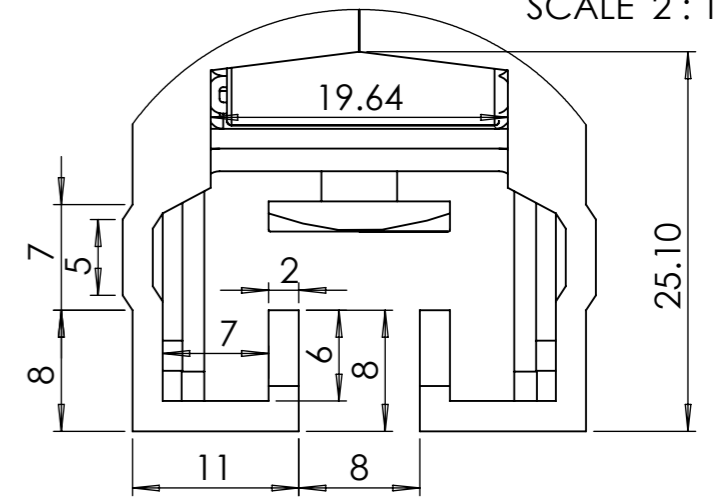

SECTION A-A
SCALE 1 : 1.3

DETAIL B
SCALE 2 : 1



COMPANY NAME:		ANAND SYSTEM ENGINEERING PVT LTD		DO NOT SCALE DRAWING.	REVISION:
		<p>Email id: info@anandcontrol.in</p> <p>CONTACT NO: 9137620579</p>		<p>TITLE:</p> <p>EXPANSION JOINT ASSEMBLY W-TYPE 2D</p>	
FINISH:		MATERIAL:		DWG NO.	
MFG:		WEIGHT:		DATE:	
SAURABH				SIGNATURE:	
				A	
				SCALE:	
				SHEET: 1 OF 1	

4

3

2

1

F

F

E

E

D

D

C

C

B

B

A

A

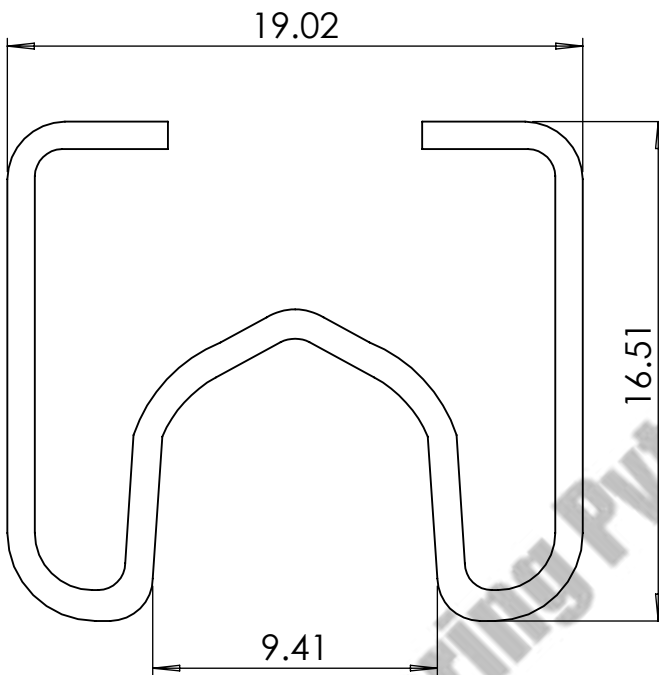

COMPANY NAME:



**ANAND SYSTEM
ENGINEERING PVT LTD**

DO NOT SCALE DRAWING.

REVISION:

TITLE:

**AL-CU W TYPE
DSL 2D**

Email id: info@anandcontrol.in

CONTACT NO: 9137620579

FINISH:

DWG NO.

DATE:

SIGNATURE:

A

DRAWN	SAURABH
CHK'D	
APP'D	
MFG	

MATERIAL:

WEIGHT:

SCALE:

SHEET: 1 OF 1

4

3

2

1

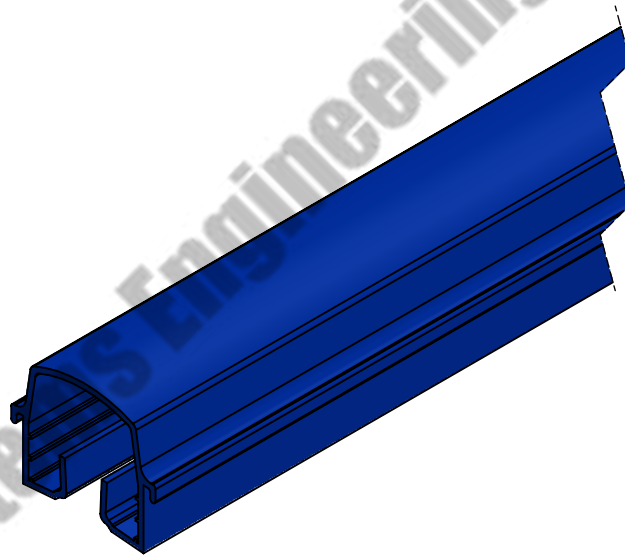
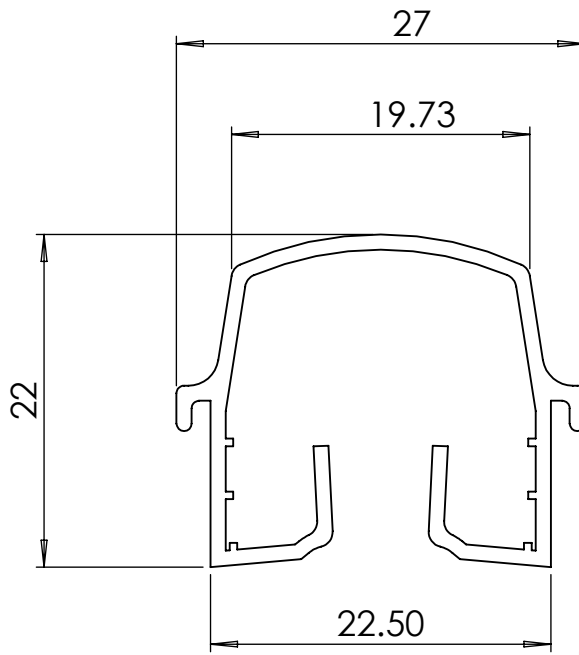

COMPANY NAME:



**ANAND SYSTEM
ENGINEERING PVT LTD**

DO NOT SCALE DRAWING.

REVISION:

TITLE:

**SLEEVE W
TYPE 2D**

Email id: info@anandcontrol.in

CONTACT NO: 9137620579

FINISH:

DWG NO.

DATE:

SIGNATURE:

DRAWN	SAURABH
CHK'D	
APP'D	
MFG	

MATERIAL:

WEIGHT:

SCALE:

SHEET: 1 OF 1

A

4

3

2

1

F

F

E

E

D

D

C

C

B

B

A

A

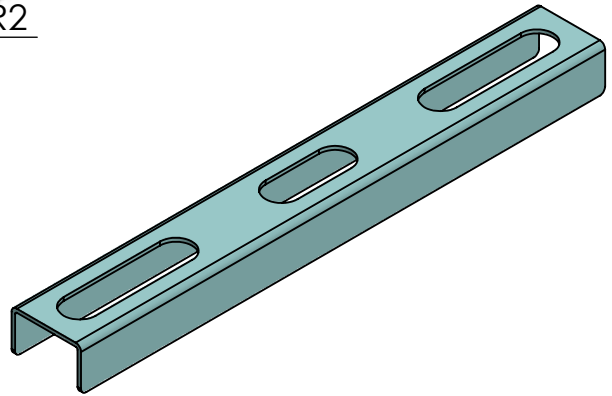
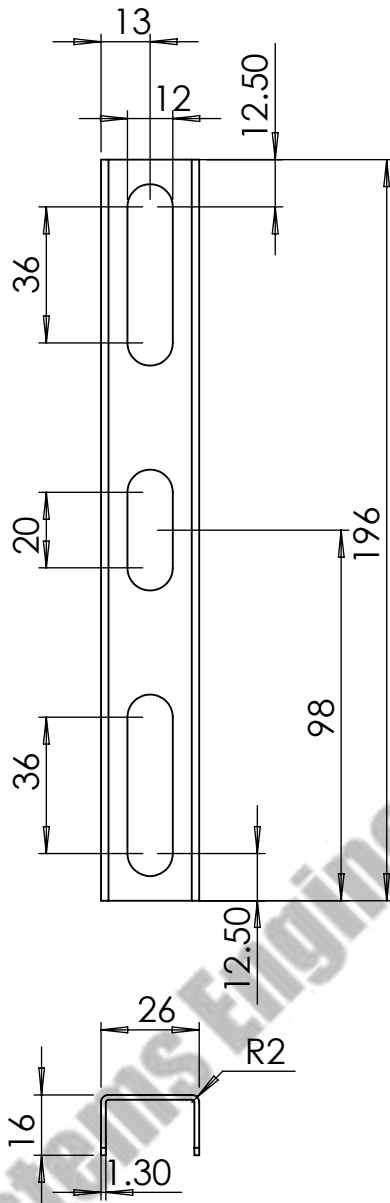

COMPANY NAME:



ANAND SYSTEM
ENGINEERING PVT LTD

Email id: info@anandcontrol.in

CONTACT NO: 9137620579

FINISH:

DO NOT SCALE DRAWING.

REVISION:

TITLE:

CLAMP
EXPANSION
W-TYPE 2D

DWG NO.

DATE:

SIGNATURE:

A

DRAWN	SAURABH
CHK'D	
APP'D	
MFG	

MATERIAL:

WEIGHT:

SCALE:

SHEET: 1 OF 1

4

3

2

1

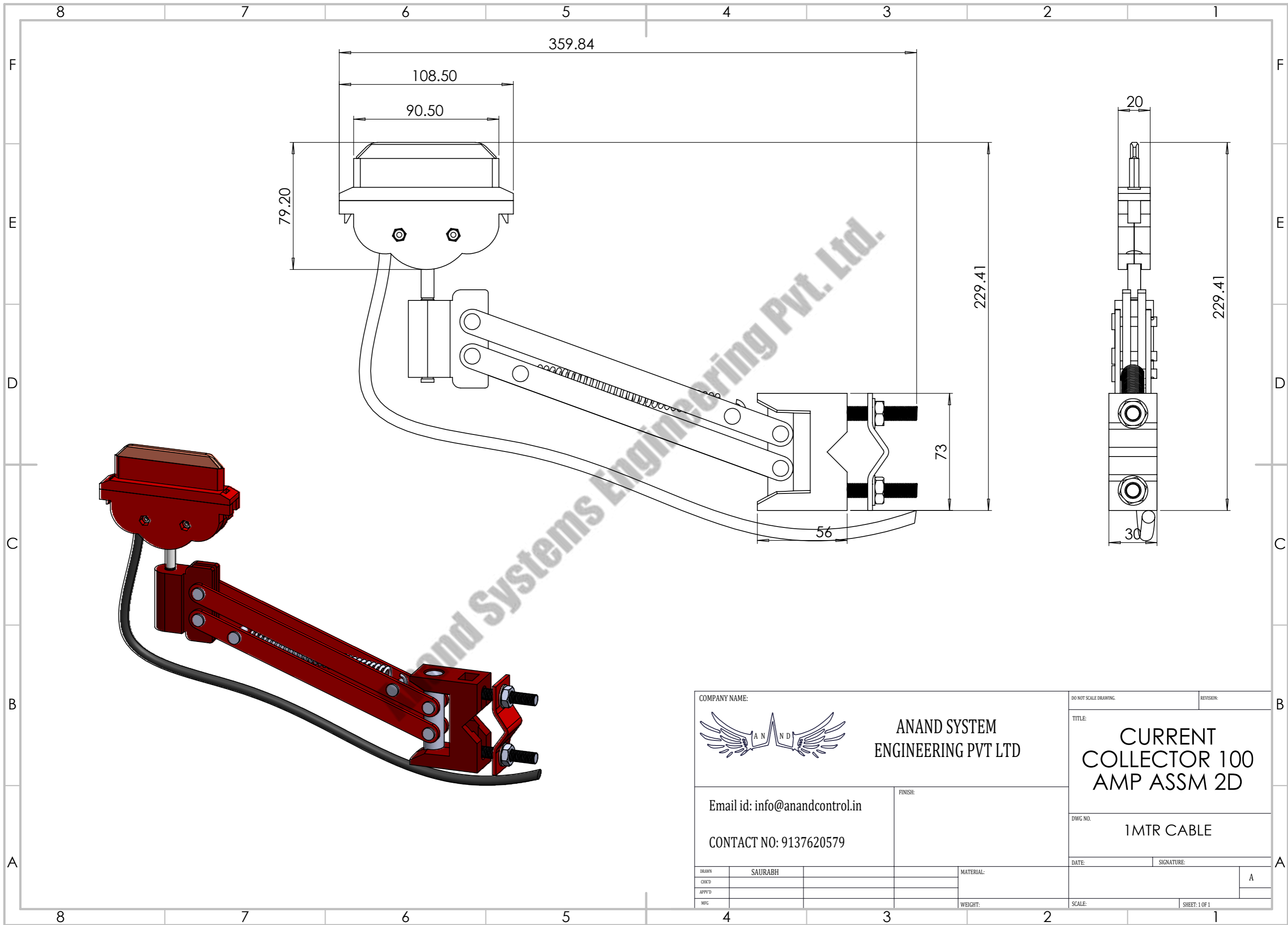

Anand Systems Engineering Pvt. Ltd.

COMPANY NAME:		ANAND SYSTEM ENGINEERING PVT LTD		DO NOT SCALE DRAWING.	REVISION:
		Email id: info@anandcontrol.in CONTACT NO: 9137620579		TITLE:	
				CURRENT COLLECTOR 100 AMP ASSM 2D	
DRAWN: SAURABH CHK'D: APPY'D: MFC:		FINISH: MATERIAL: WEIGHT:		DWG NO.	
				1MTR CABLE	
				DATE:	SIGNATURE:
				SCALE:	SHEET: 1 OF 1

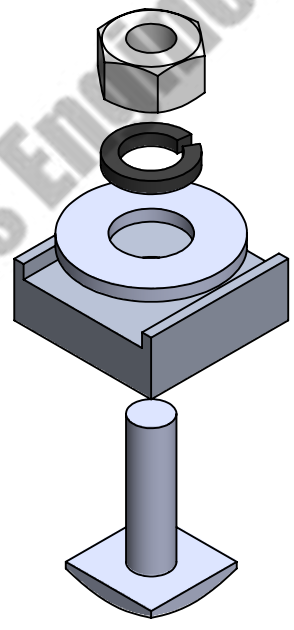
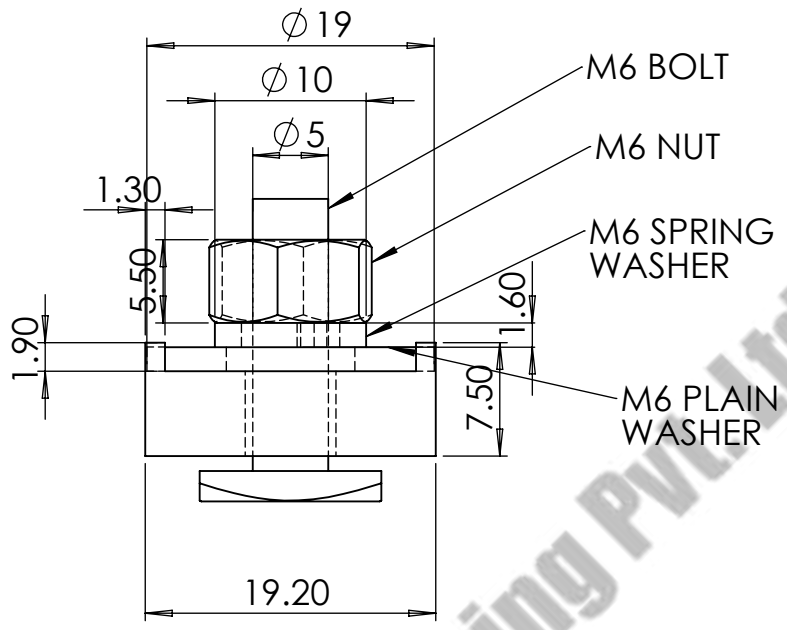

COMPANY NAME:



**ANAND SYSTEM
ENGINEERING PVT LTD**

DO NOT SCALE DRAWING.

REVISION:

TITLE:

**END CLAMP
ASSEMBLY W
TYPE 2D**

Email id: info@anandcontrol.in

CONTACT NO: 9137620579

FINISH:

DWG NO.

DATE:

SIGNATURE:

DRAWN	SAURABH			MATERIAL:			
CHK'D							A
APP'D							
MFG				WEIGHT:		SCALE:	SHEET: 1 OF 1

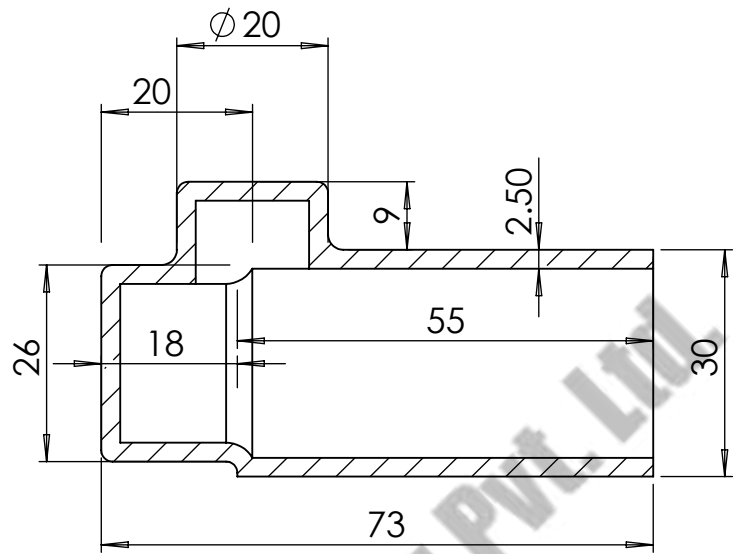
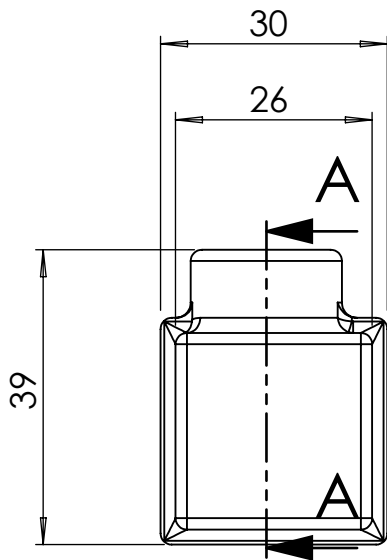

SECTION A-A

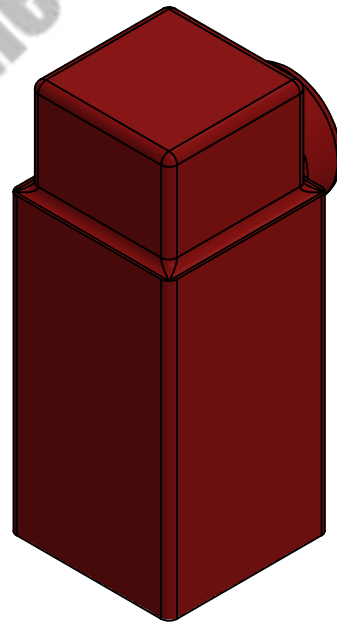

COMPANY NAME:



**ANAND SYSTEM
ENGINEERING PVT LTD**

DO NOT SCALE DRAWING.

REVISION:

TITLE:

**END COVER
W TYPE 2D**

Email id: info@anandcontrol.in

CONTACT NO: 9137620579

FINISH:

DWG NO.

DATE:

SIGNATURE:

DRAWN	SAURABH
CHK'D	
APP'D	
MFG	

MATERIAL:

WEIGHT:

SCALE:

SHEET: 1 OF 1

A

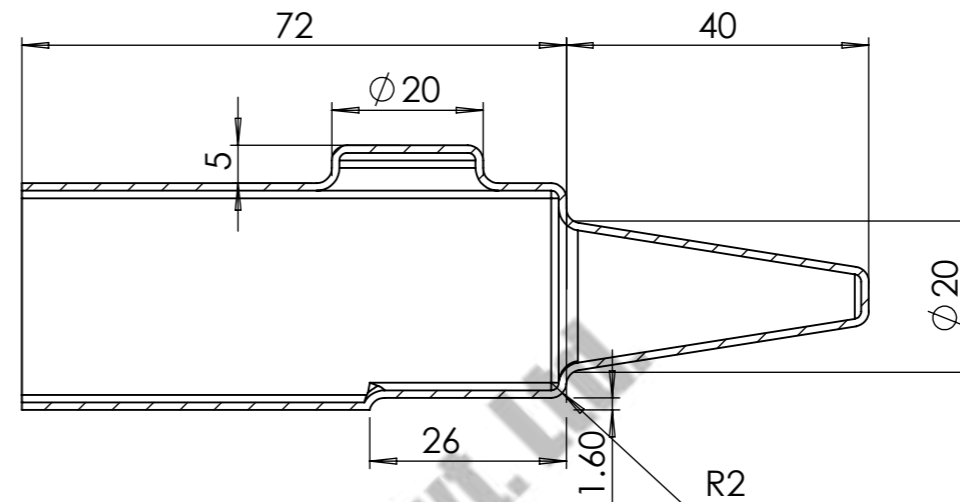
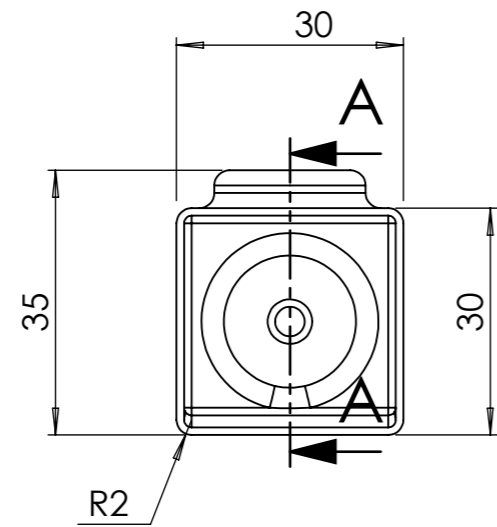

SECTION A-A

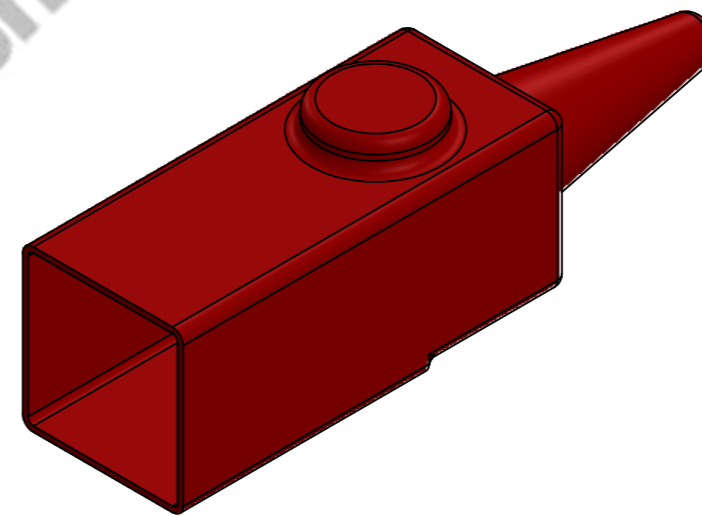
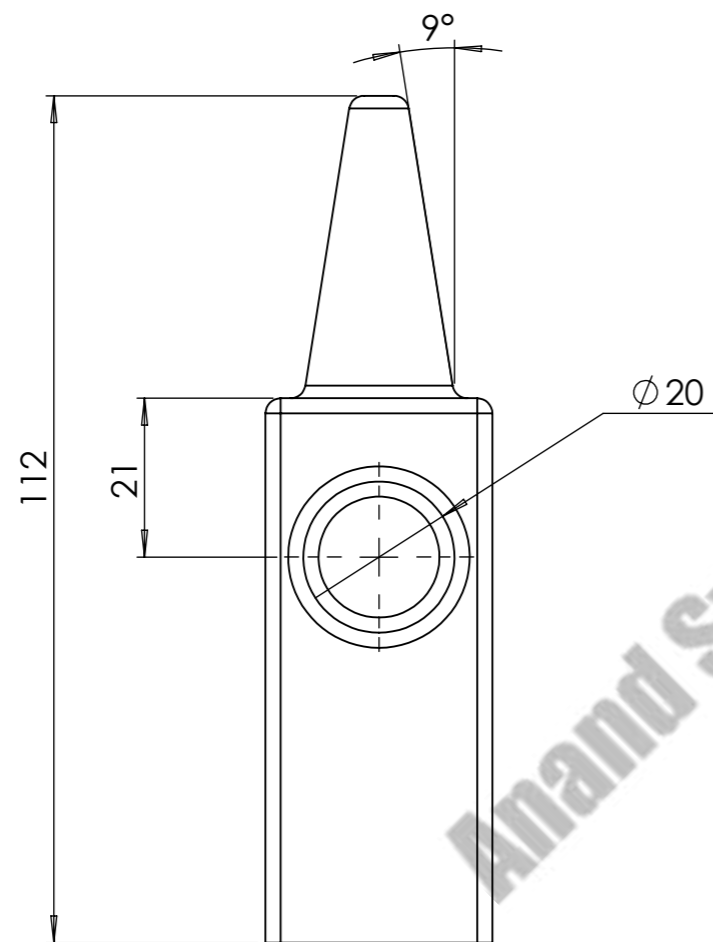

COMPANY NAME:



**ANAND SYSTEM
ENGINEERING PVT LTD**

Email id: info@anandcontrol.in

CONTACT NO: 9137620579

FINISH:

DO NOT SCALE DRAWING.

REVISION:

TITLE:

**END POWER FEED
W-TYPE 2D**

DWG NO.

DATE:

SIGNATURE:

DRAWN
CHK'D
APPV'D
MFG

SAURABH

MATERIAL:

WEIGHT:

SCALE:

SHEET: 1 OF 1

A

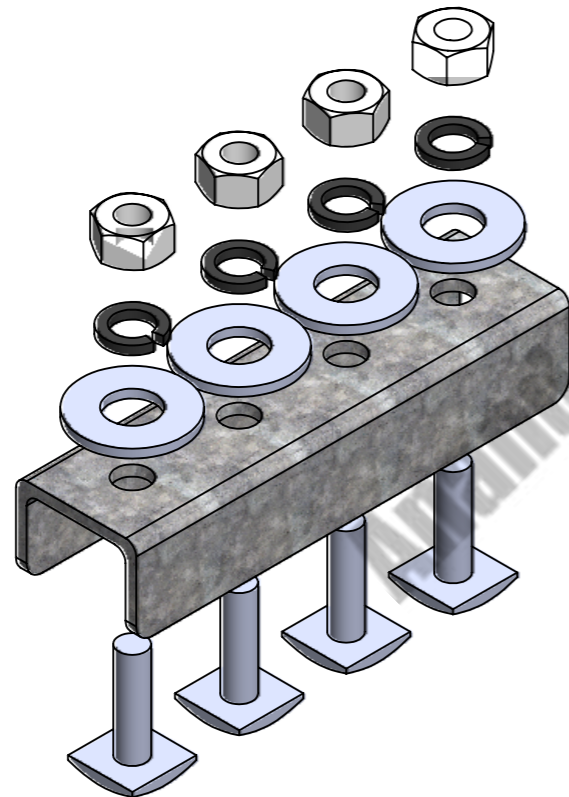
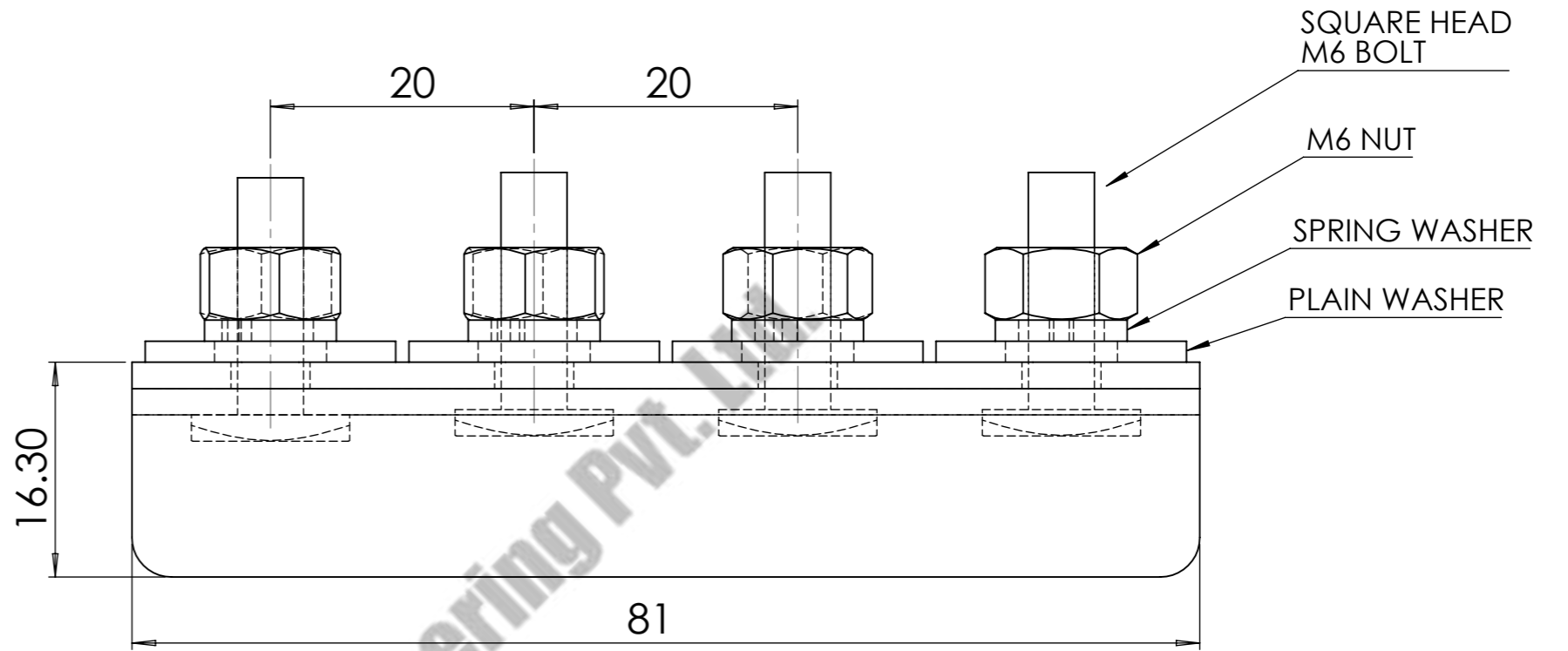
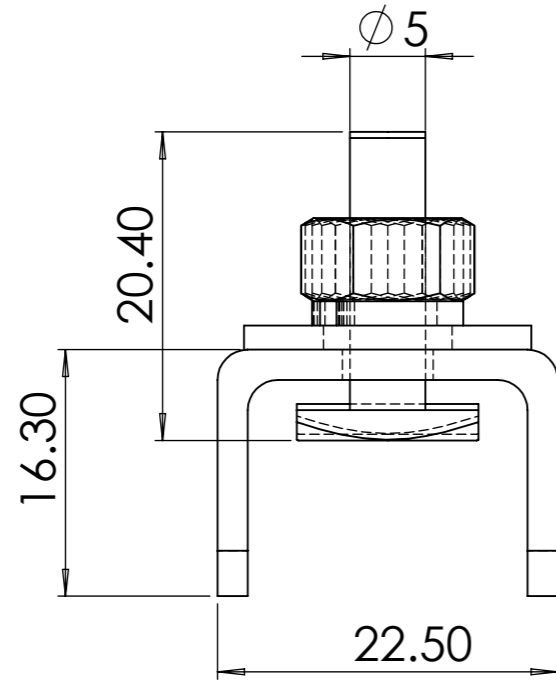

COMPANY NAME:		ANAND SYSTEM ENGINEERING PVT LTD		DO NOT SCALE DRAWING.	REVISION:
		<p>ANAND SYSTEM ENGINEERING PVT LTD</p>		TITLE: JOINT CLAMP ASSEMBLY W TYPE 2D GI	
Email id: info@anandcontrol.in		FINISH:		DWG NO.	
CONTACT NO: 9137620579				DATE:	
DRAWN: SAURABH		MATERIAL:		SIGNATURE:	
CHK'D:				A	
APP'D:					
MFG:		WEIGHT:		SCALE:	SHEET: 1 OF 1

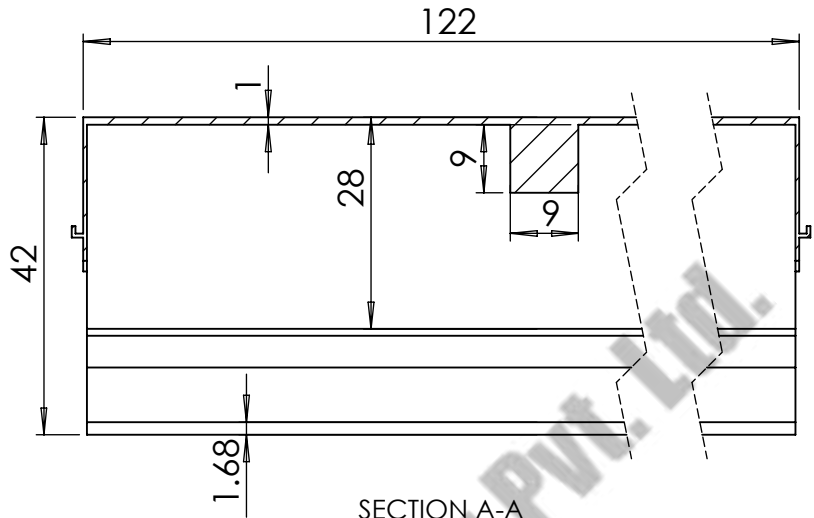
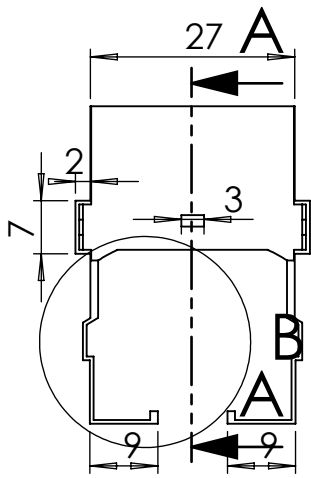

SECTION A-A
SCALE 1 : 1

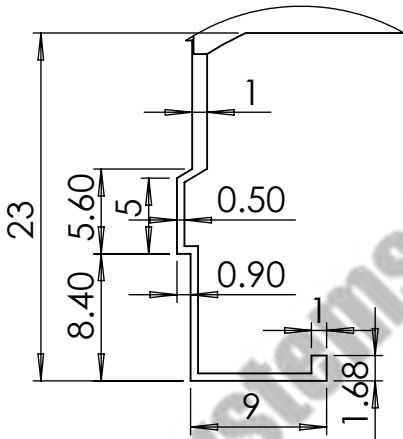

DETAIL B
SCALE 2 : 1

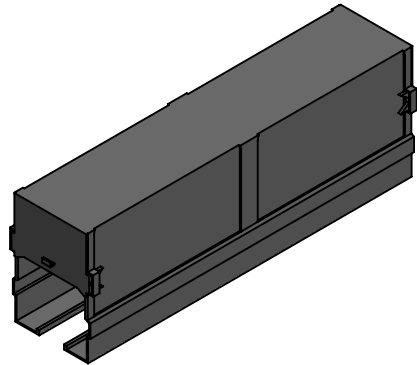

COMPANY NAME:



**ANAND SYSTEM
ENGINEERING PVT LTD**

DO NOT SCALE DRAWING.

REVISION:

TITLE:

**JOINT COVER
W-TYPE 2D**

Email id: info@anandcontrol.in

CONTACT NO: 9137620579

FINISH:

DWG NO.

DATE:

SIGNATURE:

DRAWN	SAURABH
CHK'D	
APP'D	
MFG	

MATERIAL:

WEIGHT:

SCALE:

SHEET: 1 OF 1

A

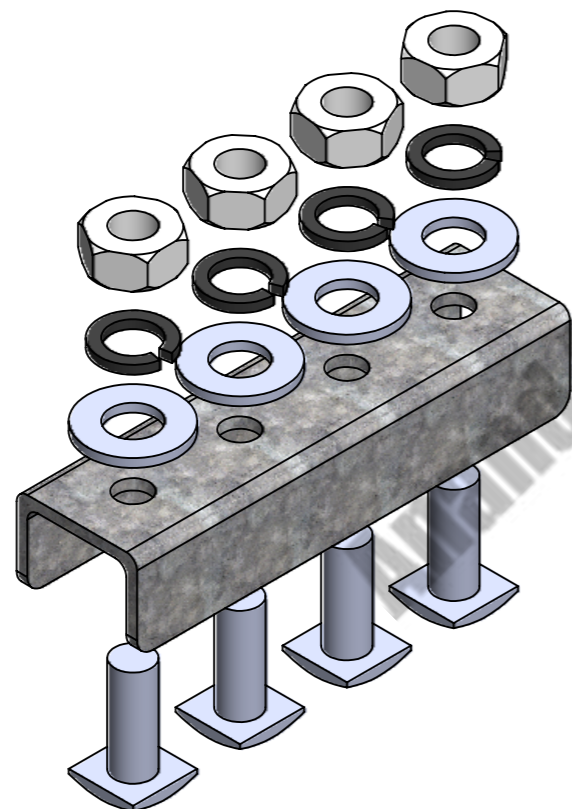
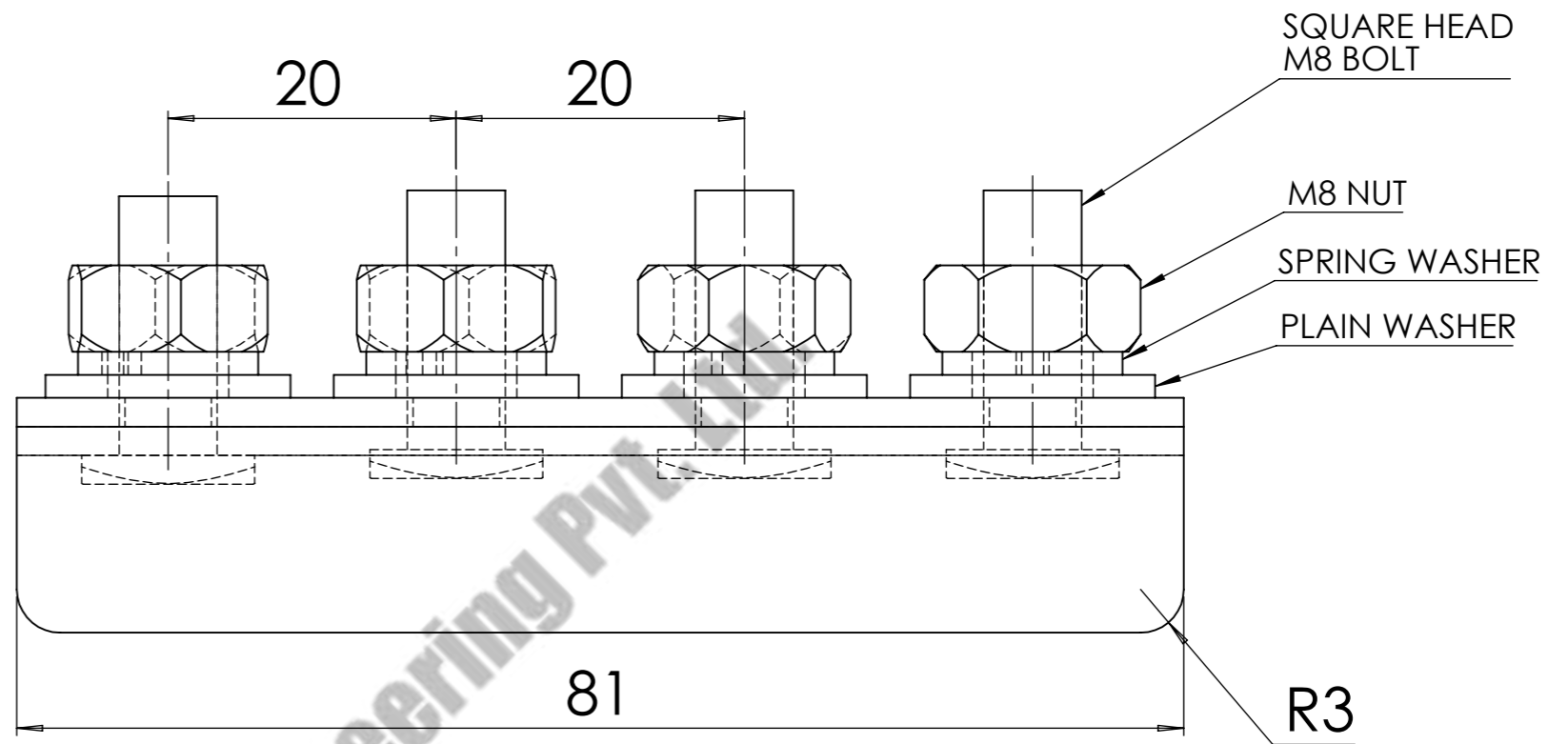
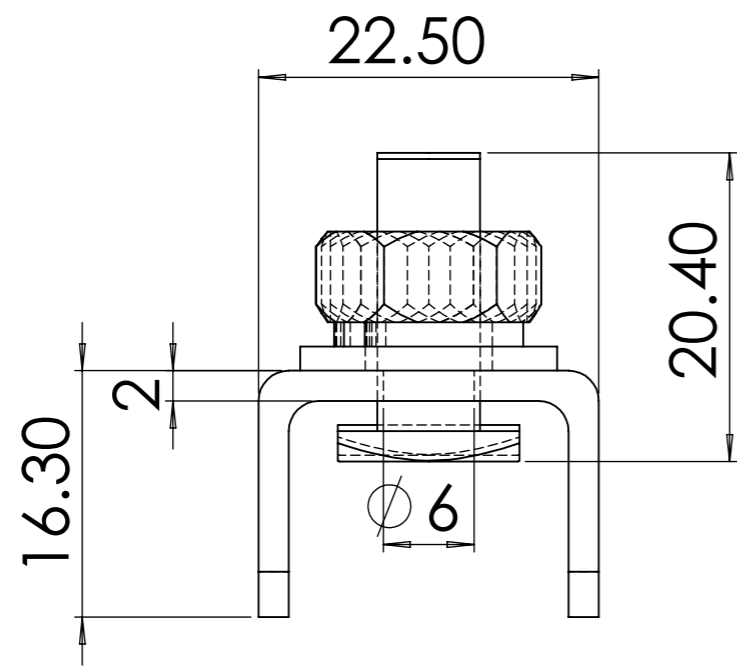

COMPANY NAME:		ANAND SYSTEM ENGINEERING PVT LTD		DO NOT SCALE DRAWING.	REVISION:
		Email id: info@anandcontrol.in CONTACT NO: 9137620579		TITLE: POWER FEED CLAMP ASSEMBLY W TYPE 2D GI	
FINISH:		DATE:		SIGNATURE:	
DRAWN	SAURABH	MATERIAL:	A		
CHK'D		WEIGHT:	SCALE:		
APPY'D		SHEET: 1 OF 1			
MFG					

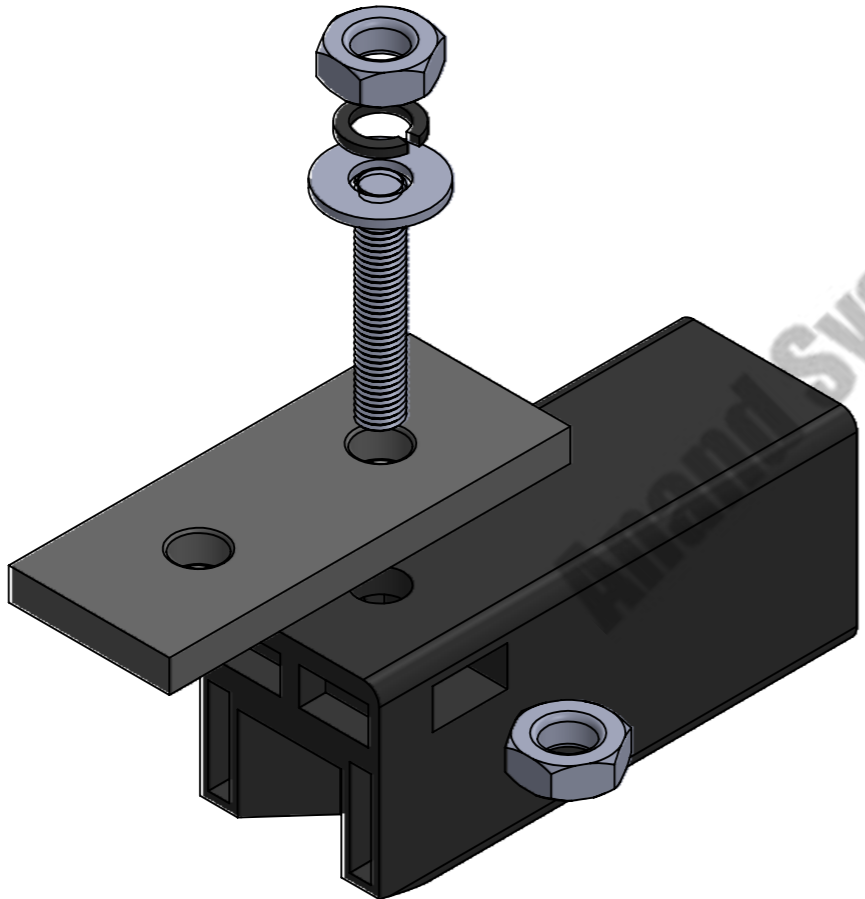
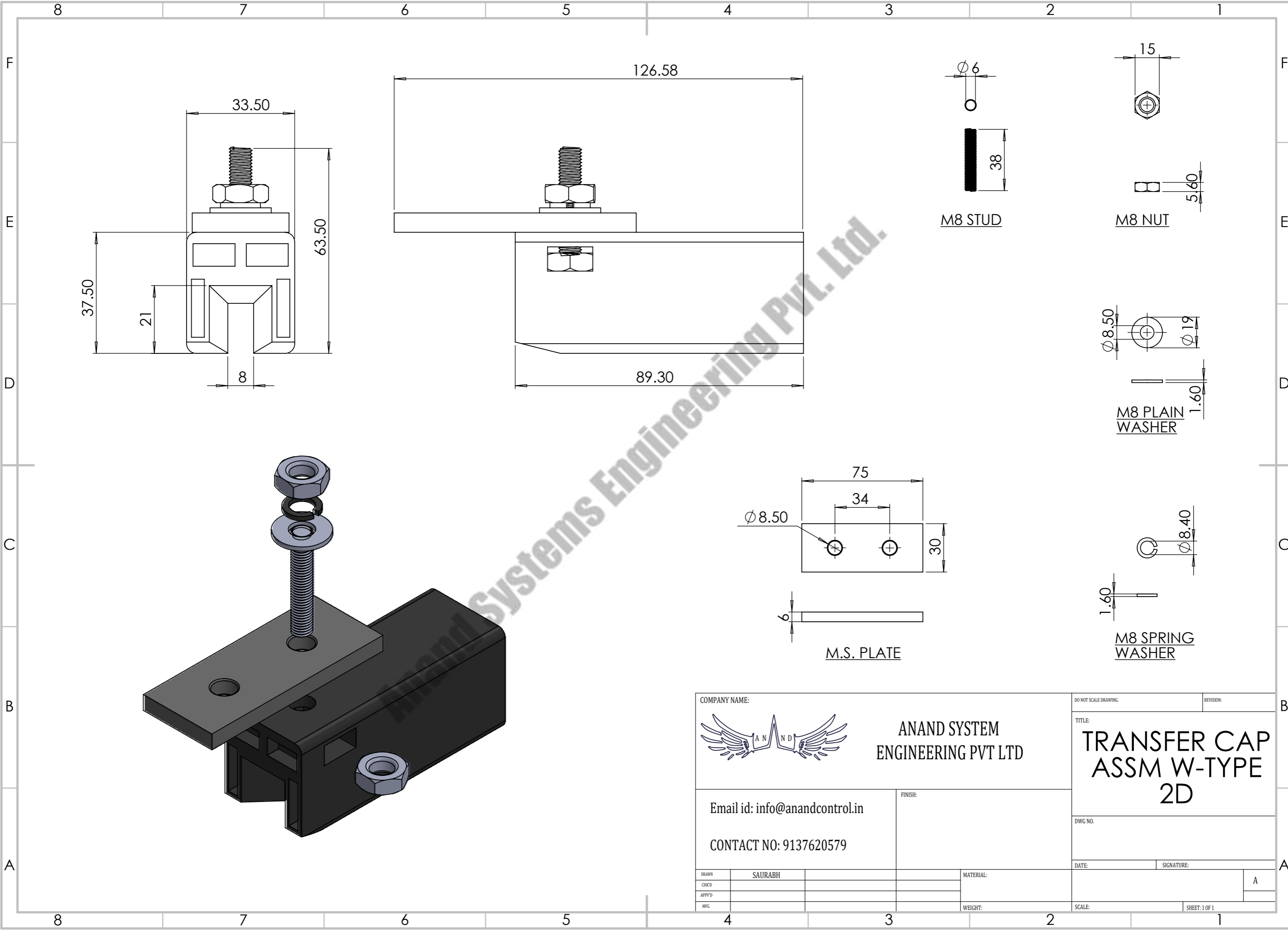

COMPANY NAME:		ANAND SYSTEM ENGINEERING PVT LTD		DO NOT SCALE DRAWING.	REVISION:
		Email id: info@anandcontrol.in CONTACT NO: 9137620579		TITLE: TRANSFER CAP ASSM W-TYPE 2D	
FINISH:		MATERIAL:		DWG NO.	
DATE:		SIGNATURE:		A	
DRAWN: SAURABH	CHK'D:	APPY'D:	MFG:	WEIGHT:	SCALE:
				SHEET: 1 OF 1	

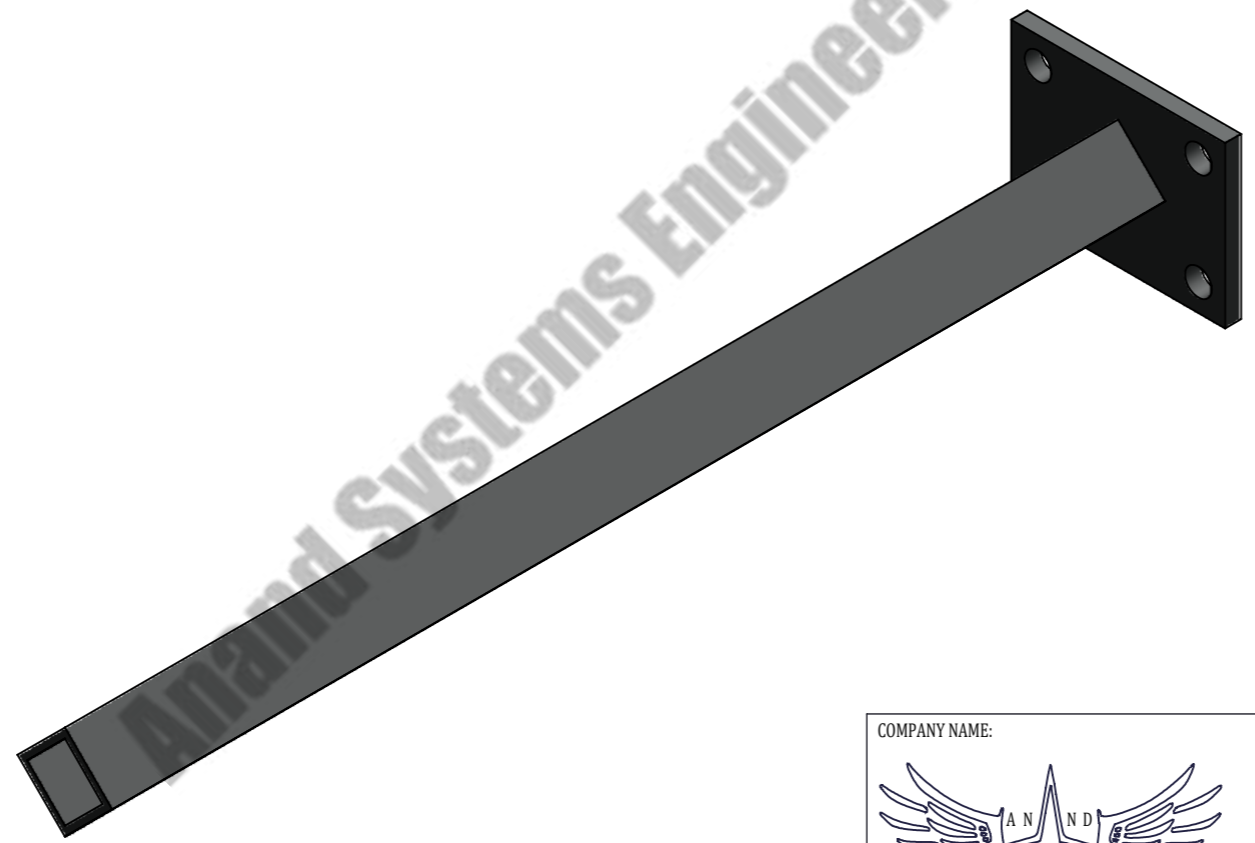
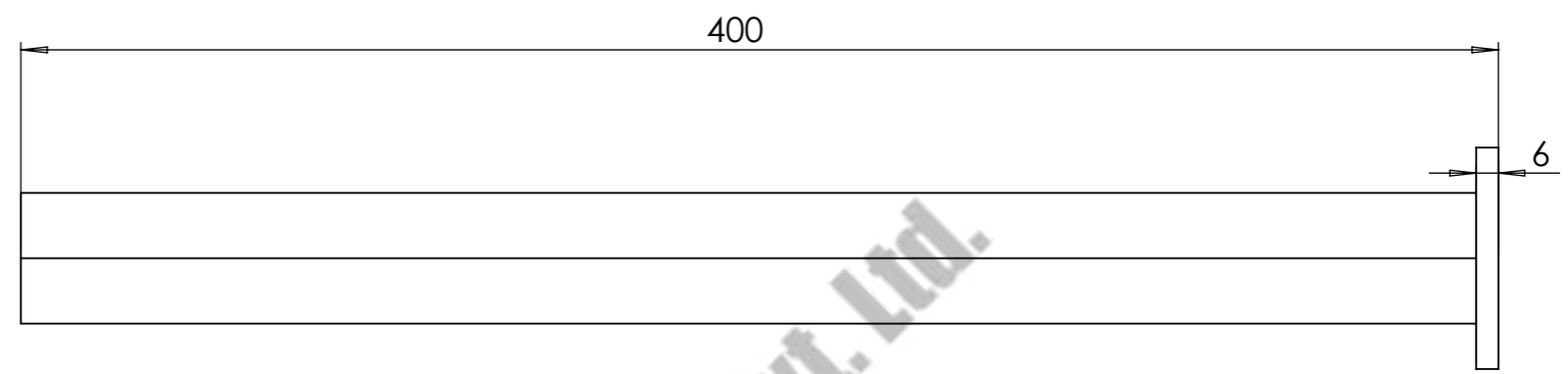
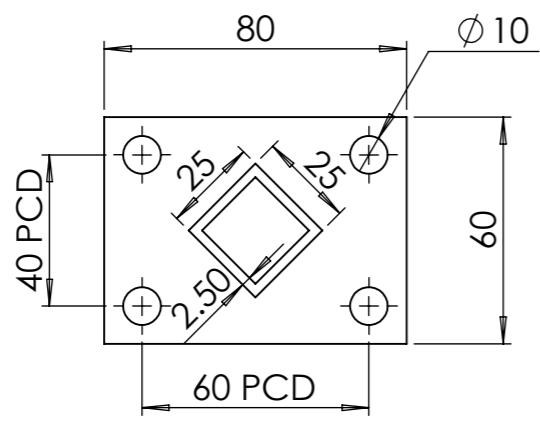

COMPANY NAME:		ANAND SYSTEM ENGINEERING PVT LTD		DO NOT SCALE DRAWING.	REVISION:
		<p>Email id: info@anandcontrol.in</p> <p>CONTACT NO: 9137620579</p>		<p>TITLE:</p> <h1>C.C-Bracket 100 AMP</h1>	
FINISH:		DATE:		SIGNATURE:	
DRAWN	SAURABH	MATERIAL:		A	
CHK'D		WEIGHT:		SCALE:	
APP'VD		SCALE:		SHEET: 1 OF 1	
MFG					

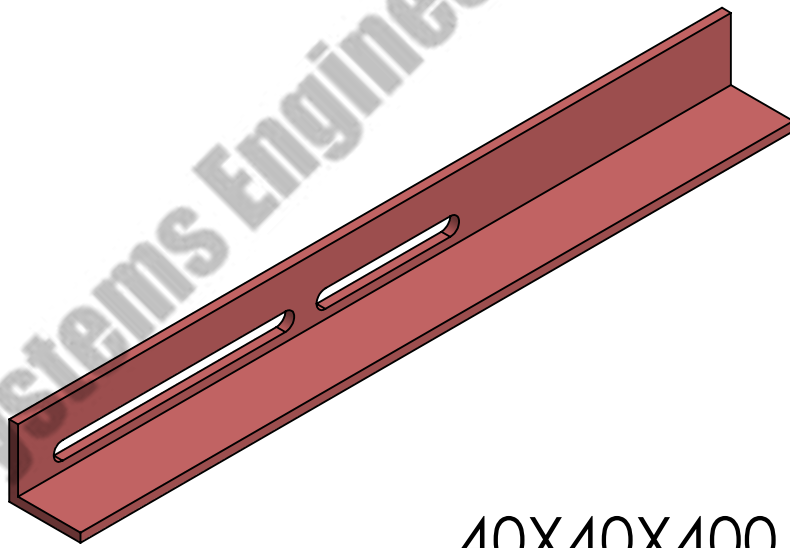
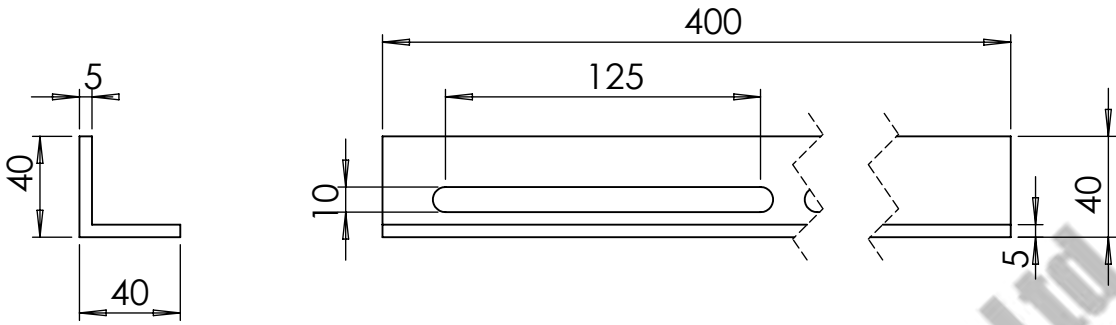

40X40X400, THK-5
MM

COMPANY NAME:



ANAND SYSTEM
ENGINEERING PVT LTD

DO NOT SCALE DRAWING.

REVISION:

TITLE:

Web-Bracket
400 W TYPE 2D

Email id: info@anandcontrol.in

CONTACT NO: 9137620579

FINISH:

DWG NO.

DATE:

SIGNATURE:

DRAWN	SAURABH
CHK'D	
APP'D	
MFG	

MATERIAL:

WEIGHT:

SCALE:

SHEET: 1 OF 1

A