

DSL V-TYPE (HEAVY TYPE) ASSEMBLY 3D

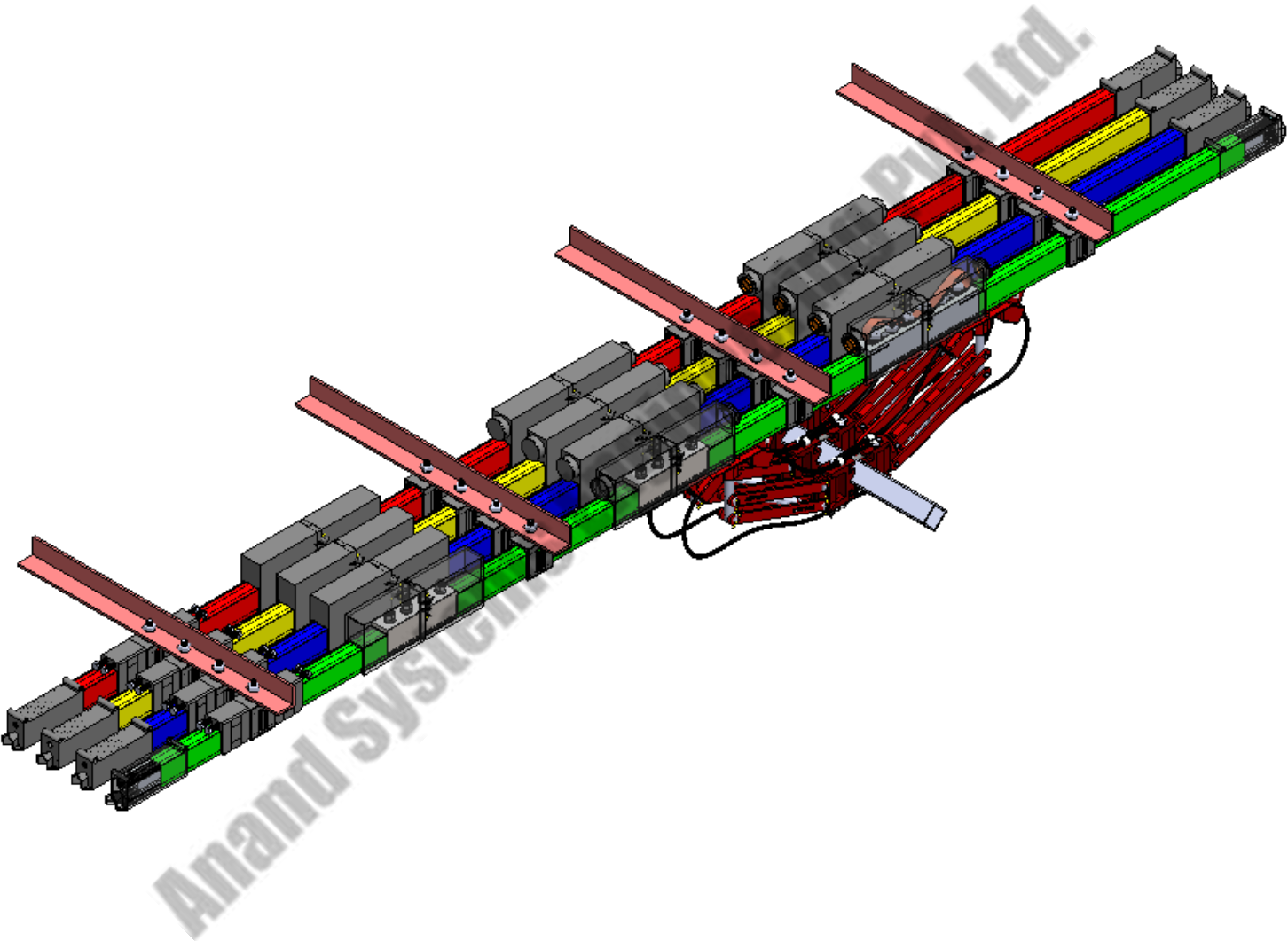

ITEM NO.	PART NAME	DESCRIPTION	MATERIAL	QTY.
1	WEB BRACKET V-TYPE	600x40x40	M.S.	4
2	CLAMP V TYPE ASSM	HANGER CLAMP	DELRIN	16
	NUT	3/8"	M.S.	1
	CLAMP BOLT	M8X38	M.S.	1
	CLAMP BUSH	3/8" X 1-1/2"	DELRIN	1
	CLAMP	44.8X63X58	DELRIN	1
	M8 PLAIN WASHER	17X8.4X1.5	M.S.	1
3				
	SPRING WASHER	M8	SPRING STEEL 4454 GRADE-02	1
	DSL VTYPE ASSEMBLY	SAFELINK AL 500AMP	ALUMINIUM	4
4	500 Amp dsl	4500X34X28	ALUMINIUM	1
	DSL SLEEVE	4500X33X44	PLASTIC	1
	JOINT CLAMP ASSEMBLY V-TYPE	JOINT CLAMP	-	4
5	JOINT CLAMP PLATE	76X20, 3/8"X1/2" BOLT	M.S.	2
	JOINT CLAMP AL	35.5X48X160	ALUMINIUM	1
	HEX NUT	3/8"	M.S.	4
	PLAIN WASHER	19X10.5X1.5	M.S.	4
	SPRING WASHER	M10	SPRING STEEL 4454 GRADE-02	4
	JOINT CLAMP COVER	100X44X143	PPCP	2
	COTTER PIN 2	1/2" X 2"	M.S.	2
	ANCHOR CLAMP ASSM V-TYPE	ANCHOR CLAMP	-	8
6	SCREW	M8 SELF THREADED SCREW	M.S.	2
	SINGLE POLE HANGER CLAMP	65.5X40.8X62.5	DELRIN	1
7	CENTRE POWER FEED ASSEMBLY	-	-	4
	JOINT CLAMP PLATE	76X20, 3/8"X1/2" BOLT	M.S.	2
	JOINT CLAMP AL	35.5X48X160	ALUMINIUM	1
	HEX NUT	3/8"	M.S.	4
	PLAIN WASHER	19X10.5X1.5	M.S.	4
	SPRING WASHER	M10	SPRING STEEL 4454 GRADE-2	4
	CENTRE POWER FEED COVER	100X44X143	PPCP	2
	COTTER PIN 2	1/2" X 2"	M.S.	2
	EXPANSION JOINT ASSEMBLY V-TYPE	321X80X30	-	4
	8	EXPANSION JOINT CLAMP	35.5X48X250	ALUMINIUM
COPPER SLEEVE		20X20	COPPER	4
COPPER SLEEVE 2		20X59	COPPER	2
PLAIN WASHER		19X10.5X1.5	M.S.	8
COPPER COIL FLAT 2		1mm THICKNESS	COPPER	2
EXPANSION JOINT COVER		100X44X143	PPCP	2
EXPANSION JOINT CLAMP PLATE		76X20, 2 M8 BOLT	M.S.	3
COPPER COIL FLAT 1		1mm THK	COPPER	2
GRUMET		GRUMET 1"	RUBBER	2
COTTER PIN 2		1/2" X 2"	M.S.	2
NUT		3/8"	M.S.	6
9		END COVER V TYPE ASSM	-	-
	ALENKEY BOLT	M6X50	M.S.	1
	BRASS BUSH	30X Ø8	BRASS	1
	END COVER	37.5X49.5X139	PPCP	1
	PARALLEL CURRENT COLLECTOR 250 AMP	-	-	4
	ARM	220X16X3	ALUMINIUM	4
	LOWER BRACKET 2	73X56X30	M.S.	2
	LOWER PIN	M8X75	M.S.	2
	PLAIN WASHER	11X5.5X1.5	M.S.	16
	SHOE	186.5X56X3	CARBON	2
10	SHOE HOLDER	200X64X19	PLASTIC	4
	SPRING	TENSION SPRING	SPRING STEEL 4454 GRADE-02	2
	VERTICAL LEVER	61X50X24	M.S.	2
	VERTICAL STUD	16X110	M.S.	2
	VERTICAL STUD PIN	8X22	M.S.	2
	SPACER PIN	40X6	ALUMINIUM	8
	HEX BOLT	M8, 8X20, END COVER FIXING	M.S.	2
	HEX NUT	3/8"	M.S.	2
	PLAIN WASHER	19X10.5X1.5	M.S.	2
	E CIRCLIP	M7X25	SPRING STEEL 4454 GRADE-02	2
	COTTER PIN	1/8"X 3/4"	M.S.	8
	HEX BOLT	M5X20	M.S.	4
HEX NUT	M5	M.S.	12	
STAR SCREW	M4X6.5	M.S.	12	
WIRE TIE CLIP	CABLE CLAMP	PLASTIC	4	
CABLE LUG	25 SQ MM	COPPER	4	
CABLE 1	25 SQ mm	COPPER	1	
CABLE 2	25 SQ mm	COPPER	1	
CABLE 3	25 SQ mm	COPPER	1	
CABLE 4	25 SQ mm	COPPER	1	
CC TOWING BRACKET V-TYPE	103X103, L-500	M.S.	1	

EXPLODED VIEW

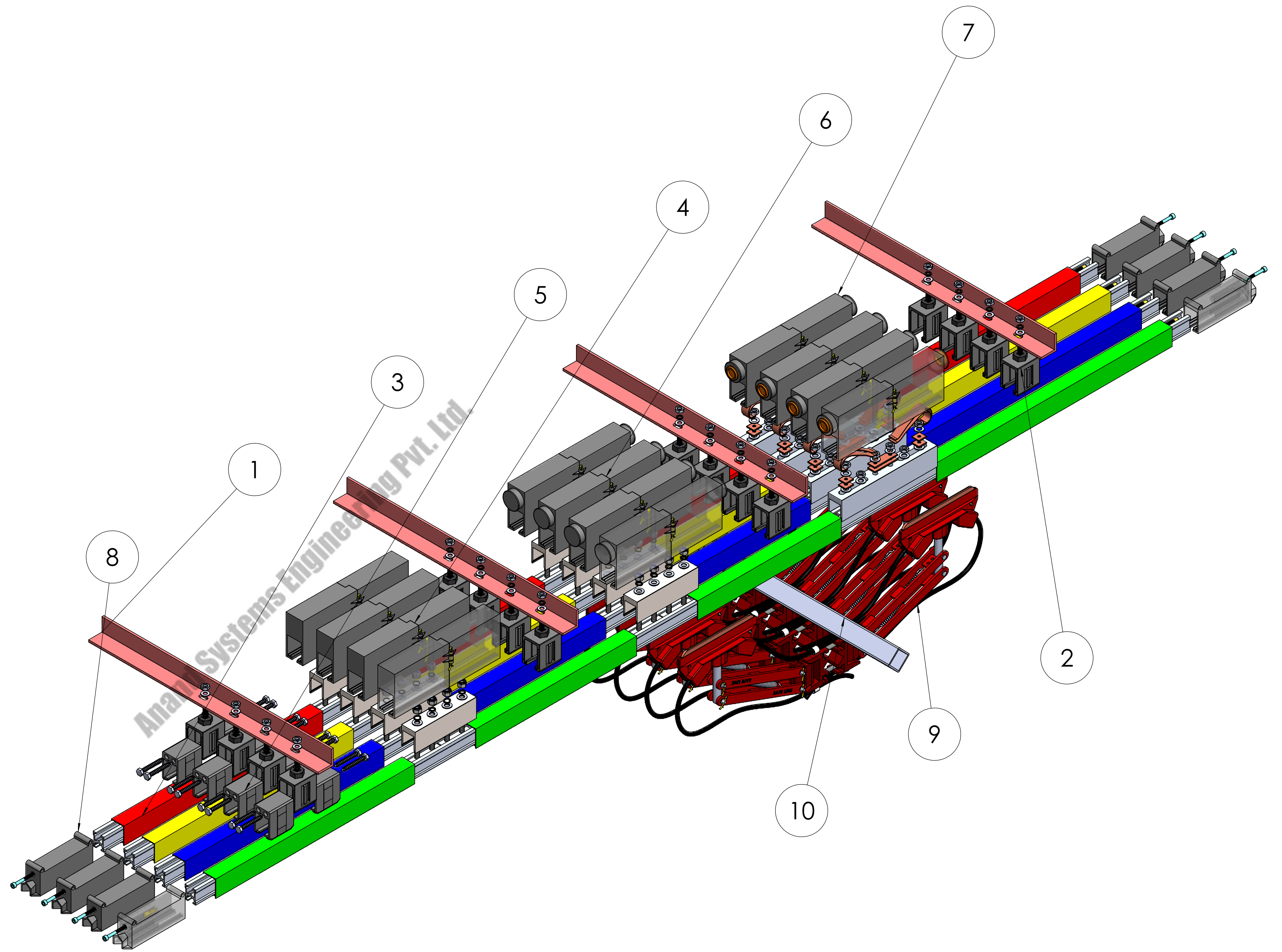

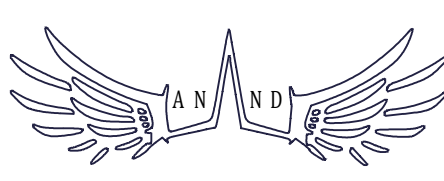
COMPANY NAME:		ANAND SYSTEM ENGINEERING PVT LTD		DO NOT SCALE DRAWING	REVISION:
		ANAND SYSTEM ENGINEERING PVT LTD		TITLE: V-TYPE DSL BUSBAR ASSEMBLY 2D	
Email id: info@anandcontrol.in		FENISE:		DWG. NO.:	
CONTACT NO: 9137620579		SCALE:		DATE: 18-12-2024 SIGNATURE:	
DRWN: SAURABH	CHKD: AJAY	MATERIAL:	A		
APPD:		WEIGHT:	SHEET: 1 OF 1		

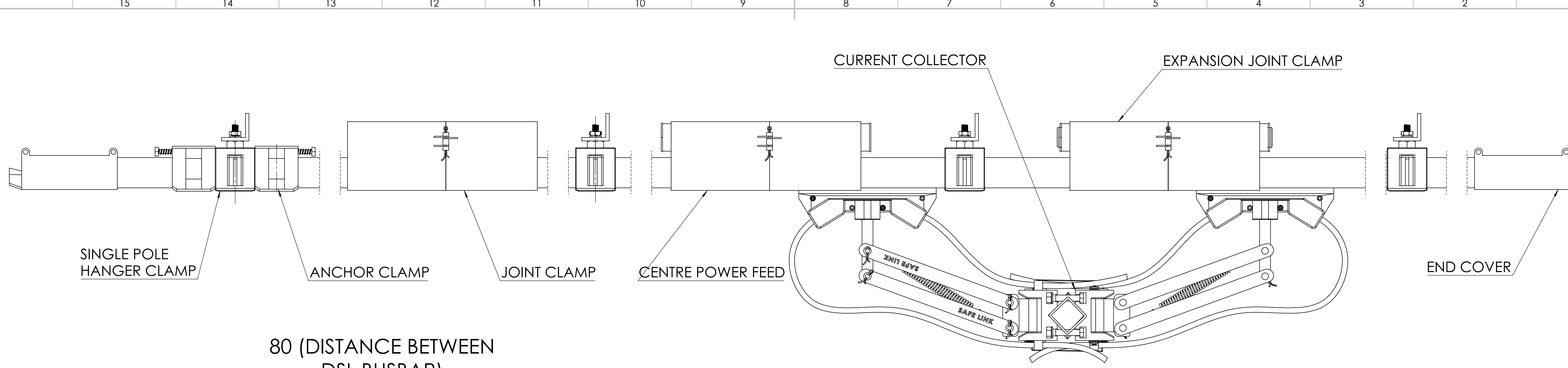

80 (DISTANCE BETWEEN DSL BUSBAR)

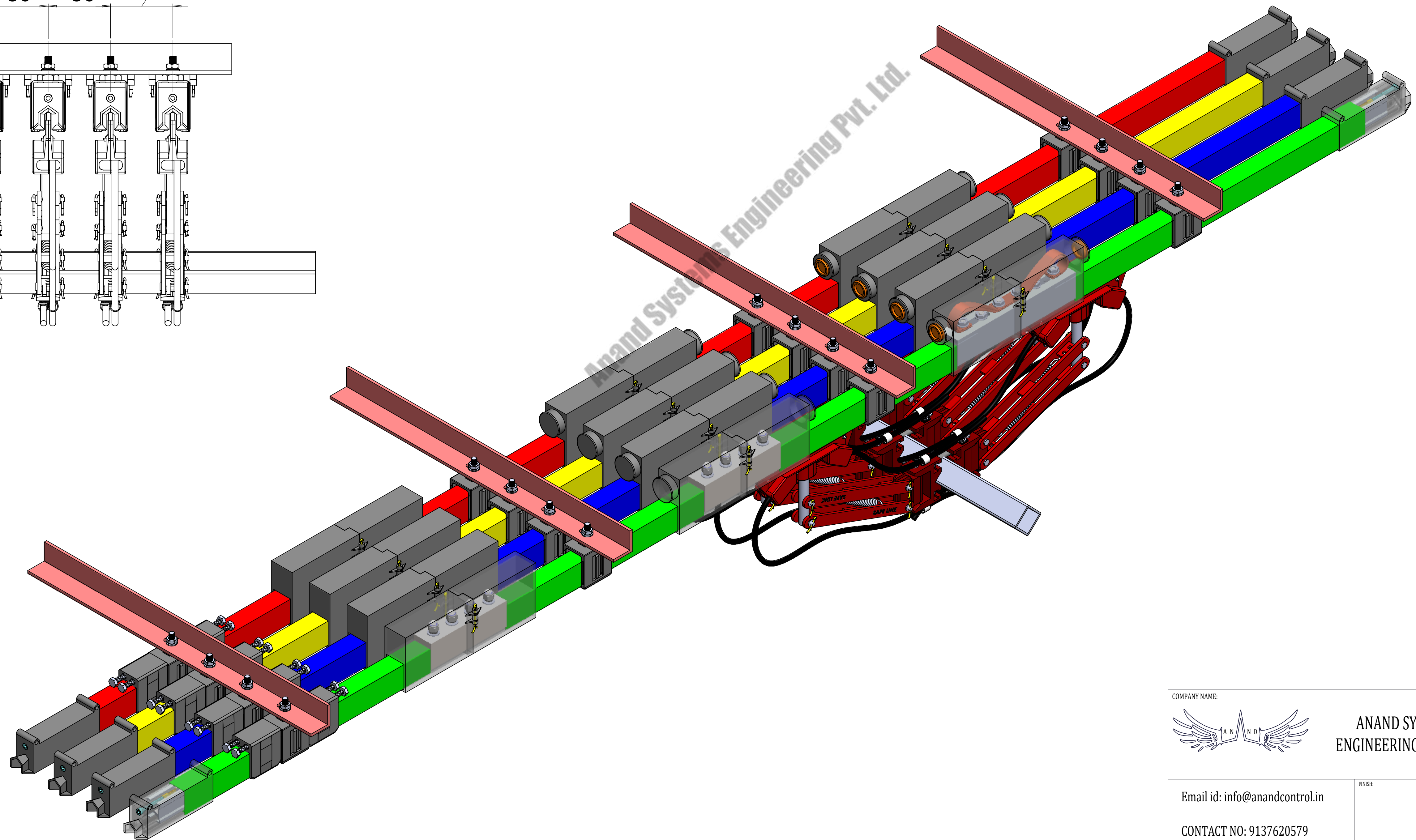
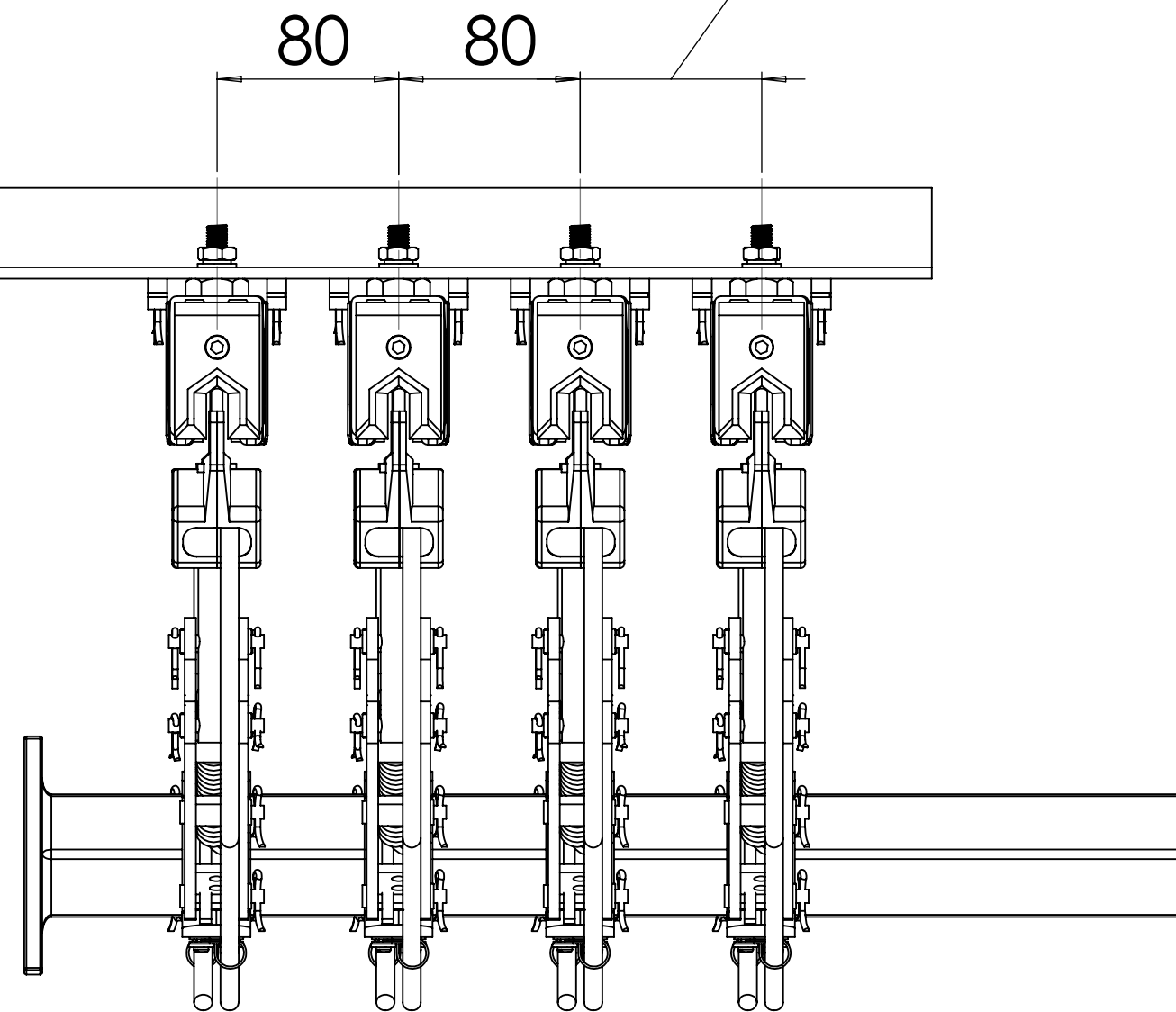

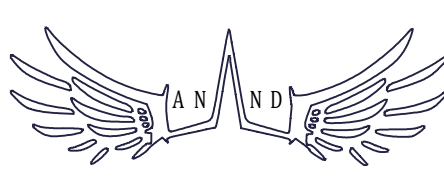
COMPANY NAME:		ANAND SYSTEM ENGINEERING PVT LTD		DO NOT SCALE DRAWING	REVISION:
		Email id: info@anandcontrol.in CONTACT NO: 9137620579		TITLE: V-TYPE DSL BUSBAR ASSEMBLY 2D	
DATE: 18-12-2024	SIGNATURE:	MATERIAL:		DWG NO:	
SCALE:	WEIGHT:	SHEET: 1 OF 1		A	

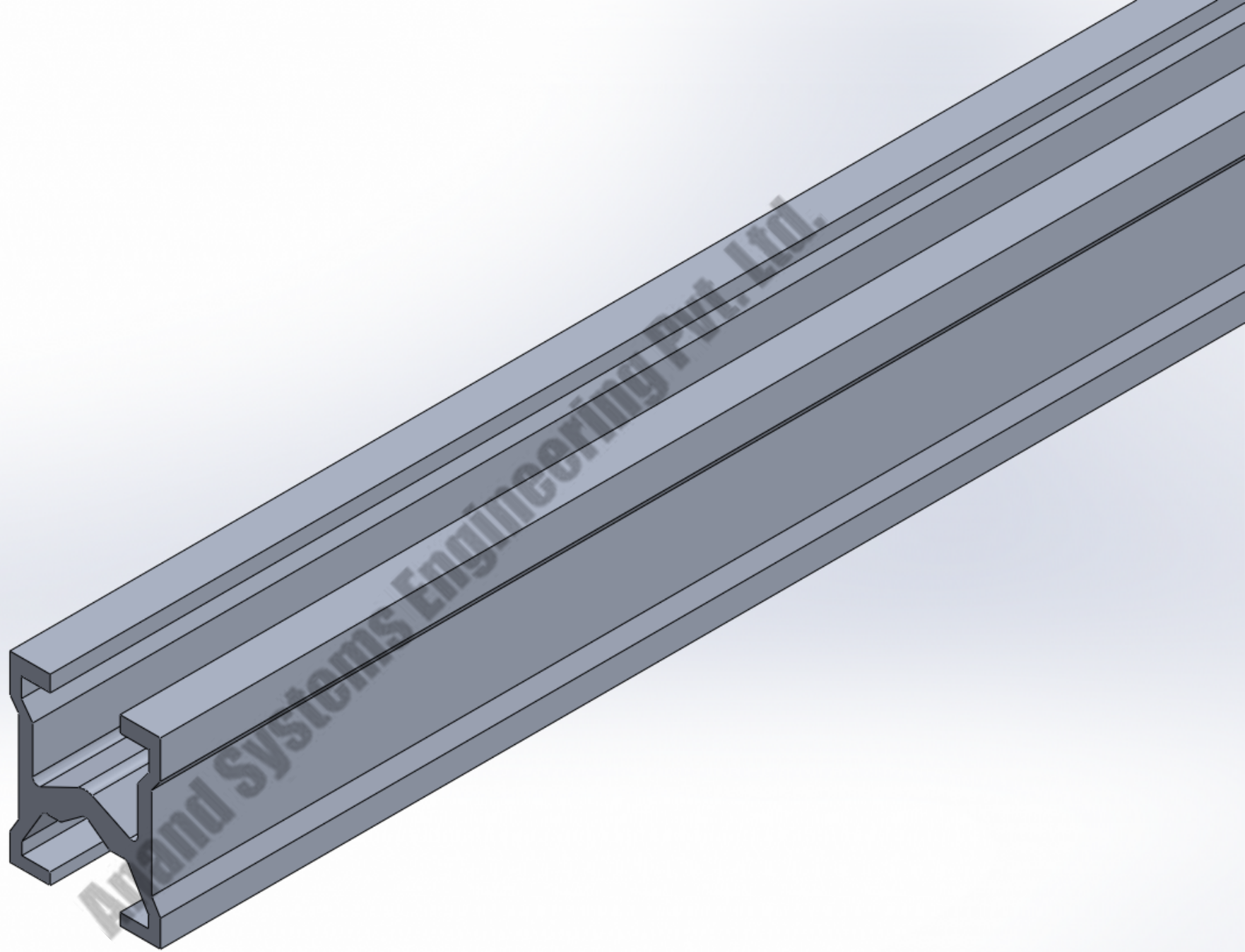

4

3

2

1

F

F

E

E

D

D

C

C

B

B

A

A

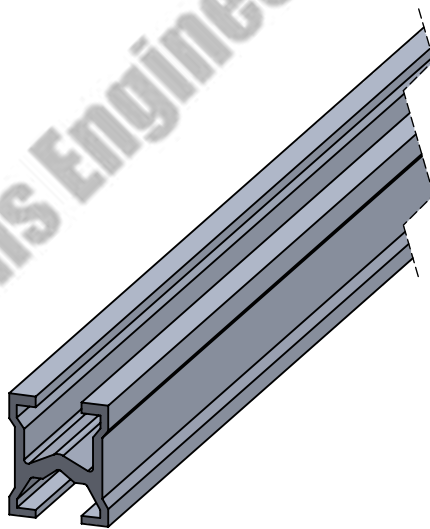
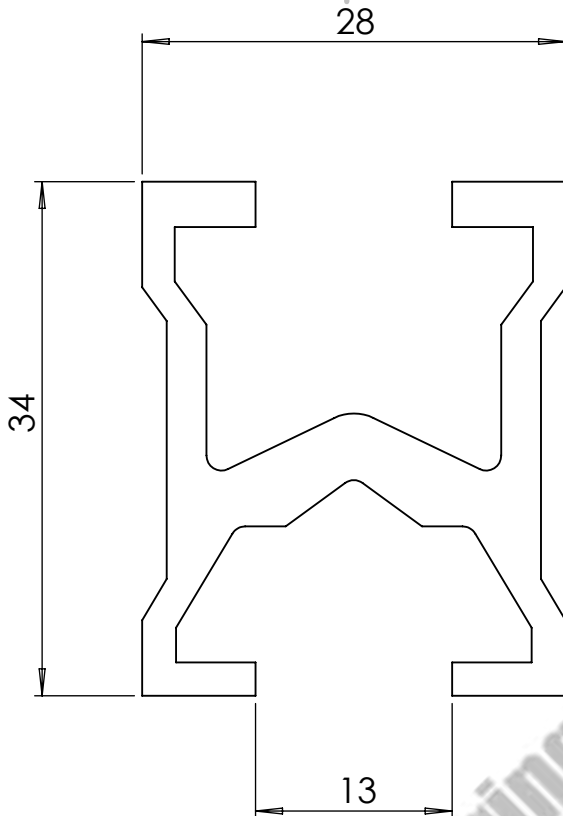

Anand Systems Engineering Pvt. Ltd.

COMPANY NAME:



**ANAND SYSTEM
ENGINEERING PVT LTD**

DO NOT SCALE DRAWING.

REVISION:

TITLE:

**500 Amp V TYPE
DSL 2D**

Email id: info@anandcontrol.in

CONTACT NO: 9137620579

FINISH:

DWG NO.

DATE:

SIGNATURE:

DRAWN	SAURABH
CHK'D	
APP'D	
MFG	

MATERIAL:

WEIGHT:

SCALE:

SHEET: 1 OF 1

4

3

2

1

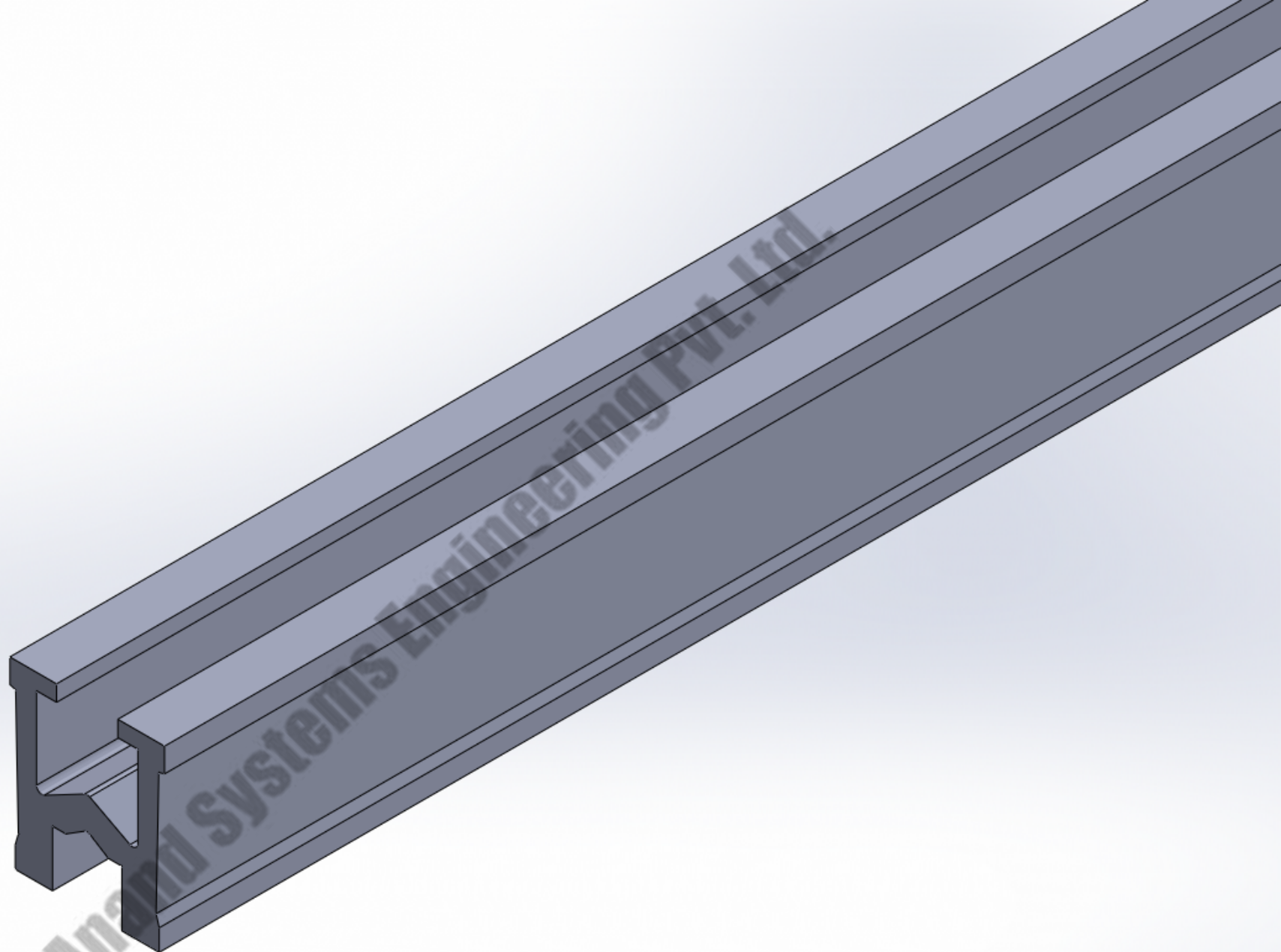

4

3

2

1

F

F

E

E

D

D

C

C

B

B

A

A

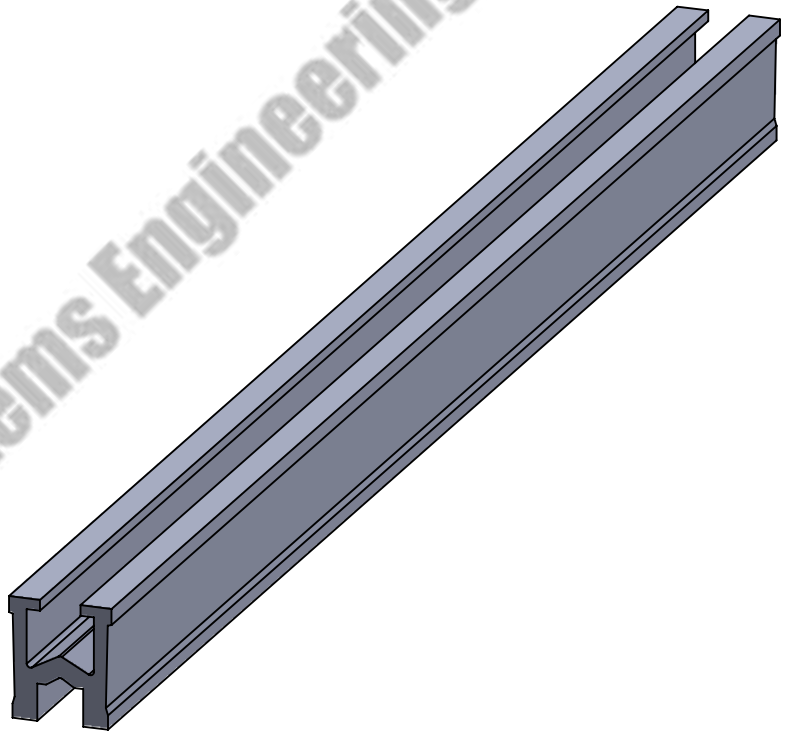
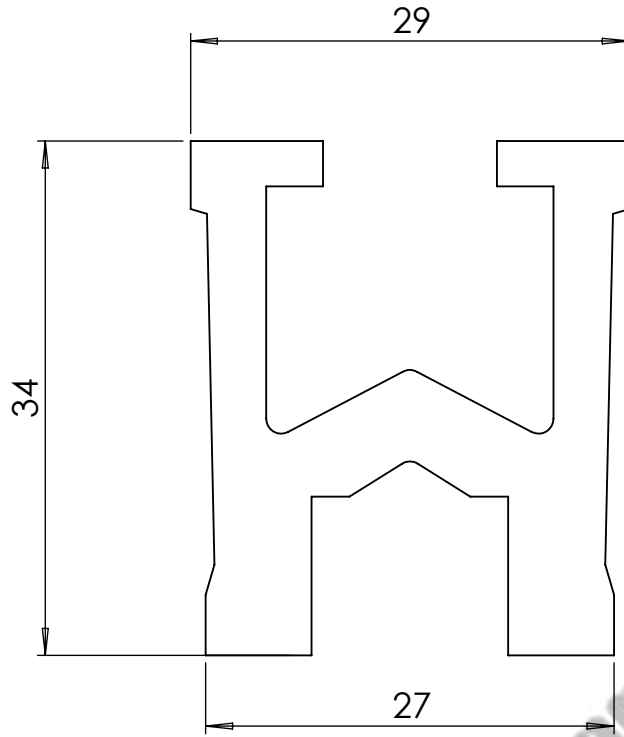

Anand Systems Engineering Pvt. Ltd.

COMPANY NAME:



**ANAND SYSTEM
ENGINEERING PVT LTD**

DO NOT SCALE DRAWING.

REVISION:

TITLE:

**800 Amp
V TYP DSL
2D**

Email id: info@anandcontrol.in

CONTACT NO: 9137620579

FINISH:

DWG NO.

DATE:

SIGNATURE:

DRAWN	SAURABH
CHK'D	
APP'D	
MFG	

MATERIAL:

WEIGHT:

SCALE:

SHEET: 1 OF 1

4

3

2

1

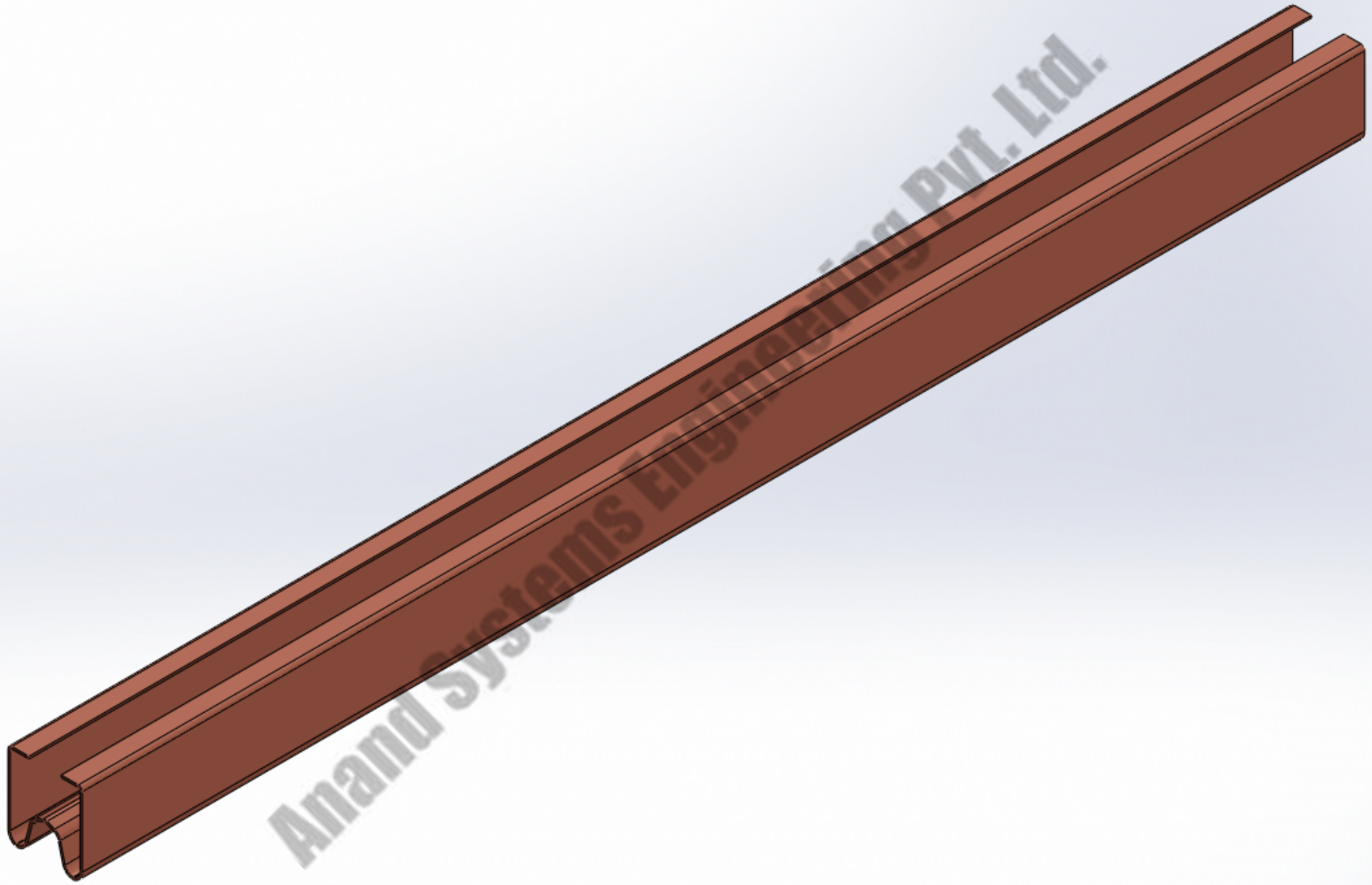

Anand Systems Engineering Pvt. Ltd.

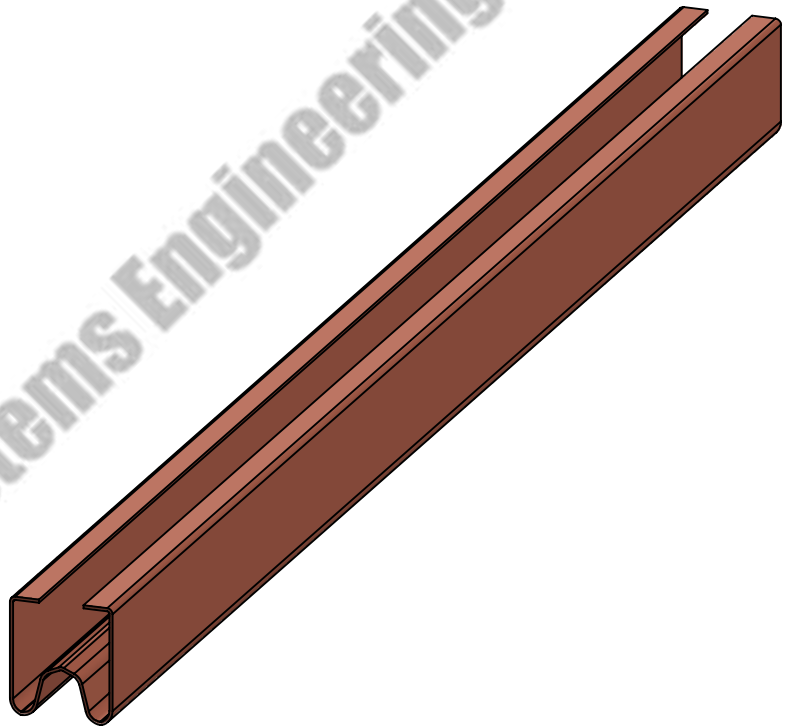
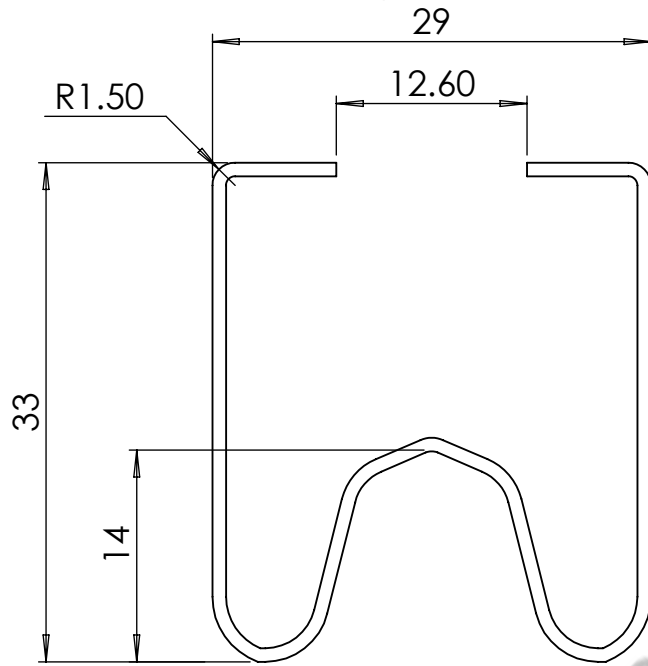

Anand Systems Engineering Pvt. Ltd.

COMPANY NAME:



**ANAND SYSTEM
ENGINEERING PVT LTD**

DO NOT SCALE DRAWING.

REVISION:

TITLE:

**DSL BUSBAR
COPPER V
TYPE 2D**

Email id: info@anandcontrol.in

CONTACT NO: 9137620579

FINISH:

DWG NO.

DATE:

SIGNATURE:

DRAWN	SAURABH
CHK'D	
APP'D	
MFG	

MATERIAL:

WEIGHT:

SCALE:

SHEET: 1 OF 1

A

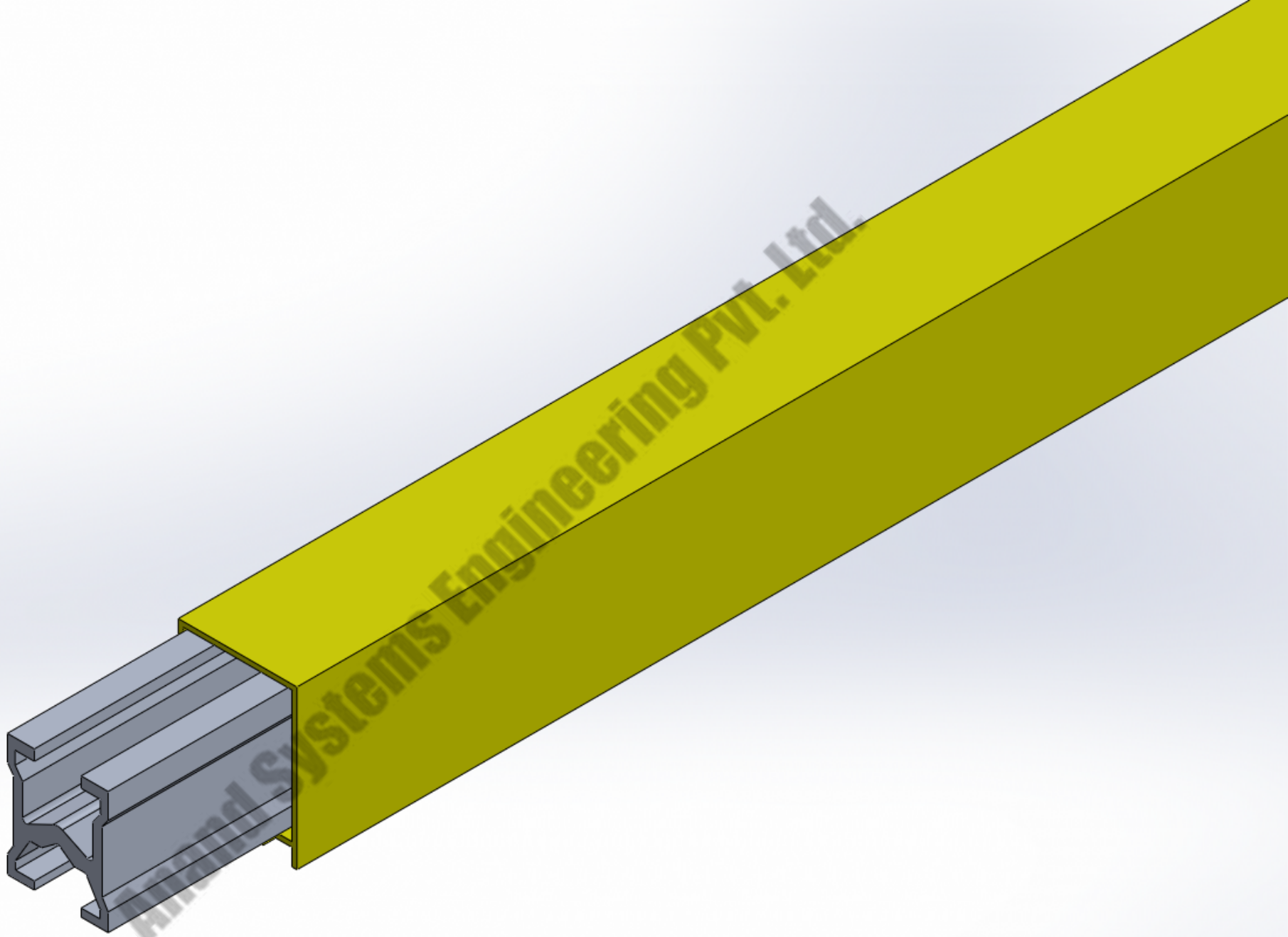

4

3

2

1

F

F

E

E

D

D

C

C

B

B

A

A

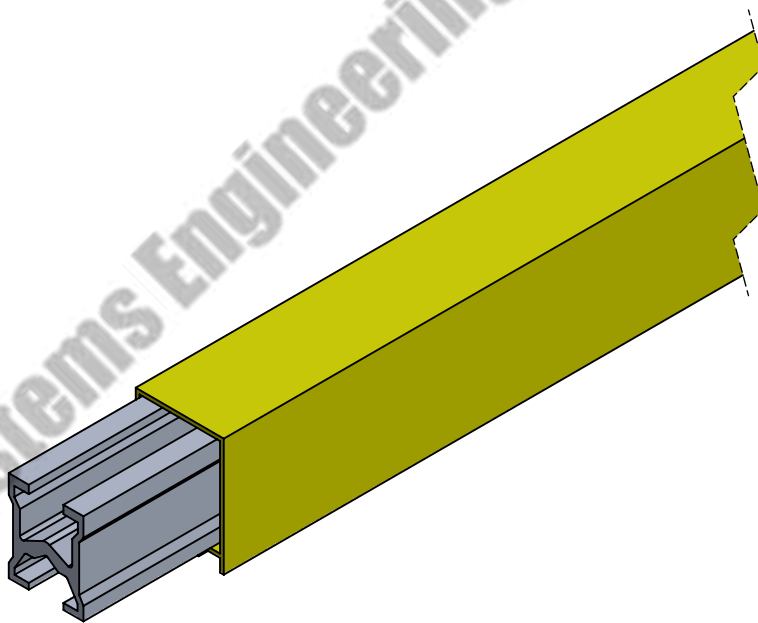
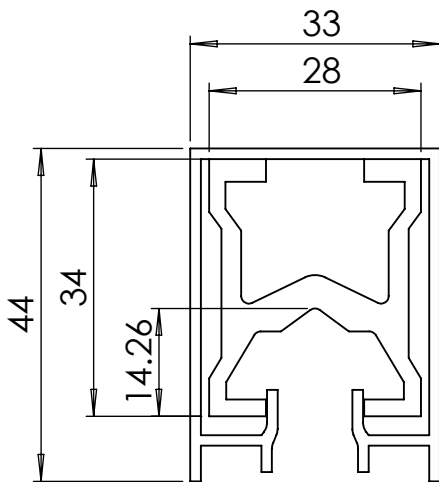

Anand Systems Engineering Pvt. Ltd.

COMPANY NAME:



ANAND SYSTEM
ENGINEERING PVT LTD

DO NOT SCALE DRAWING.

REVISION:

TITLE:

DSL V-TYPE AL
ASSEMBLY 2D

Email id: info@anandcontrol.in

CONTACT NO: 9137620579

FINISH:

DWG NO.

DATE:

SIGNATURE:

DRAWN	SAURABH
CHK'D	
APP'D	
MFG	

MATERIAL:

WEIGHT:

SCALE:

SHEET: 1 OF 1

4

3

2

1

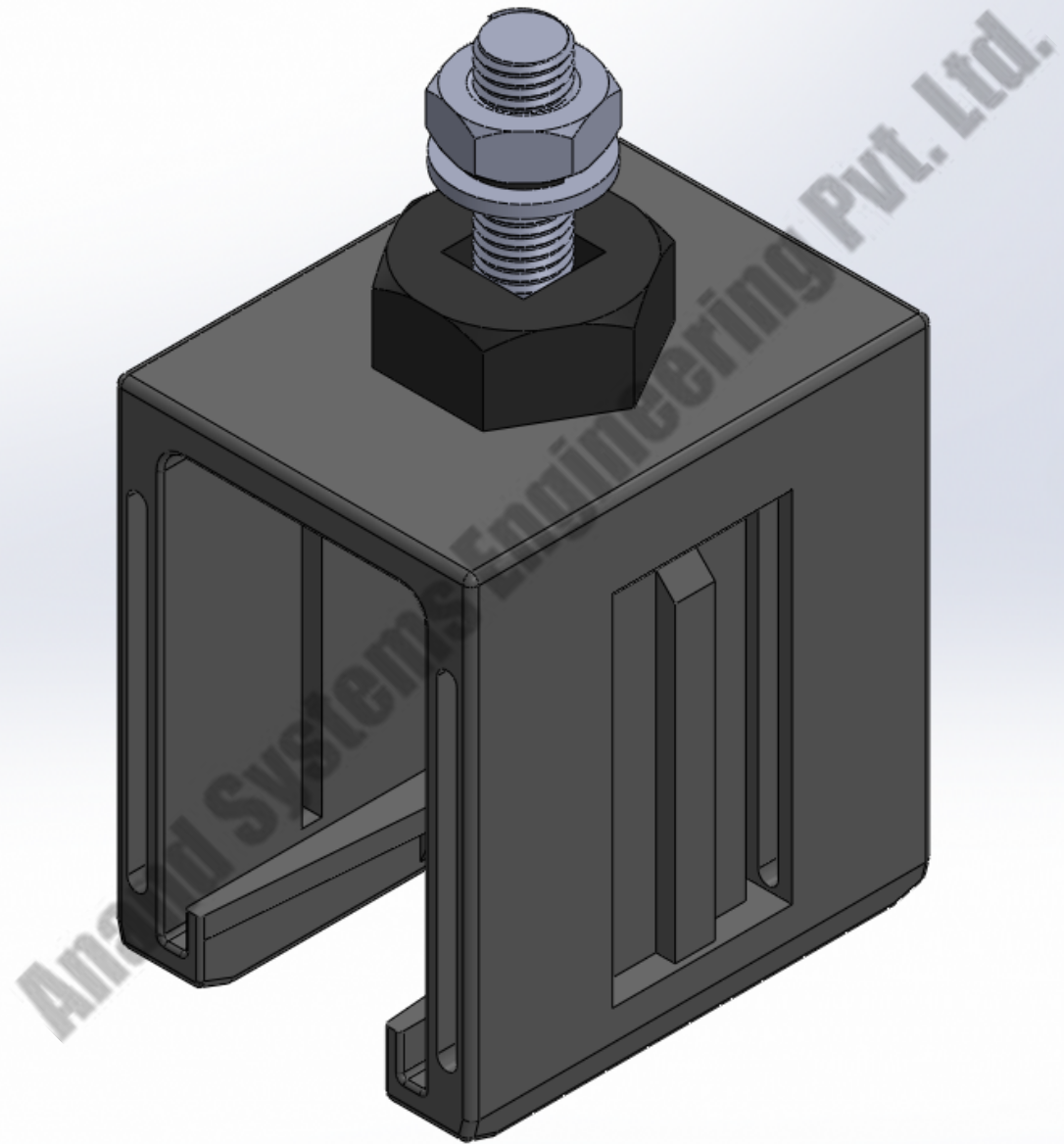

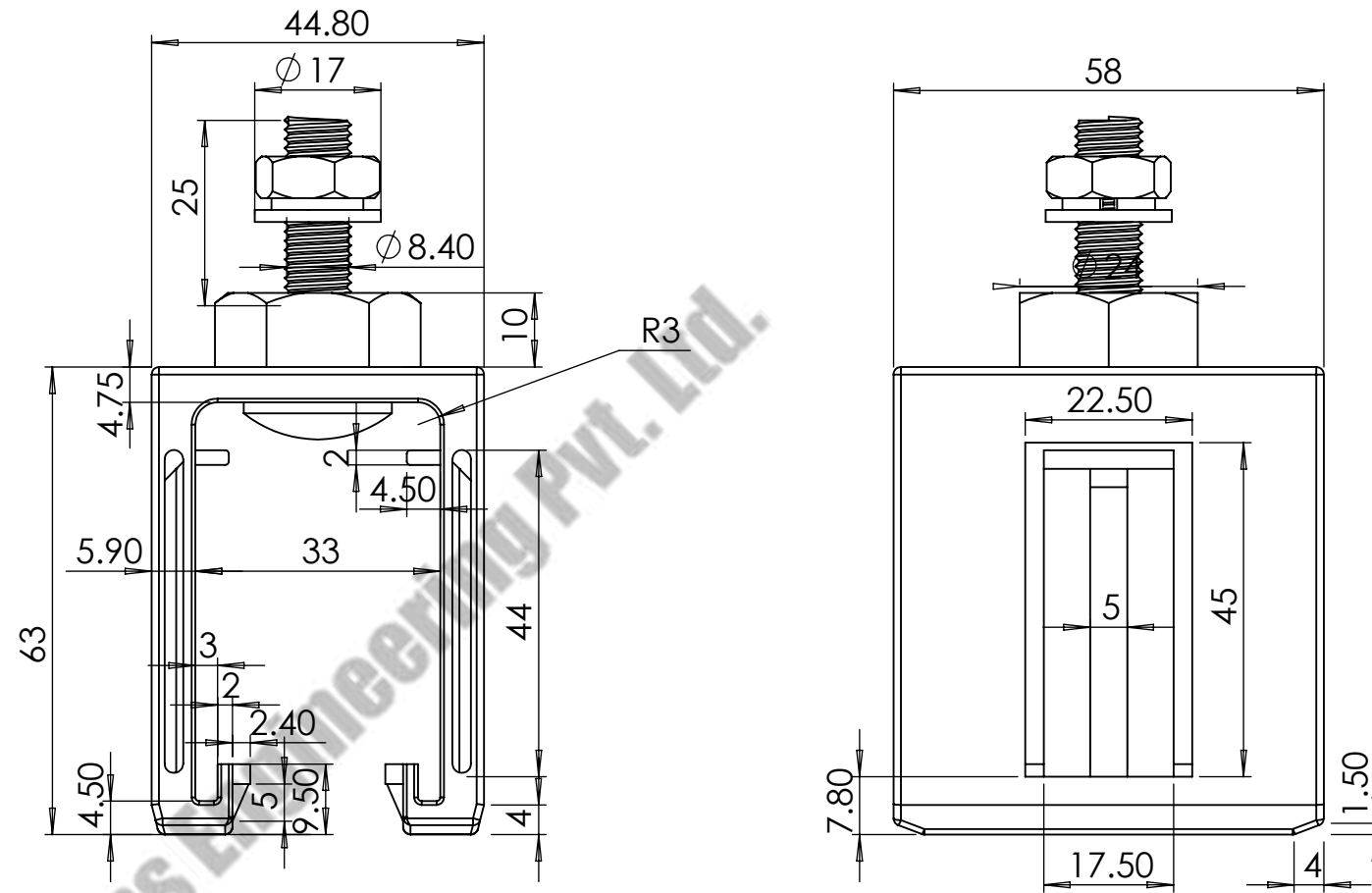
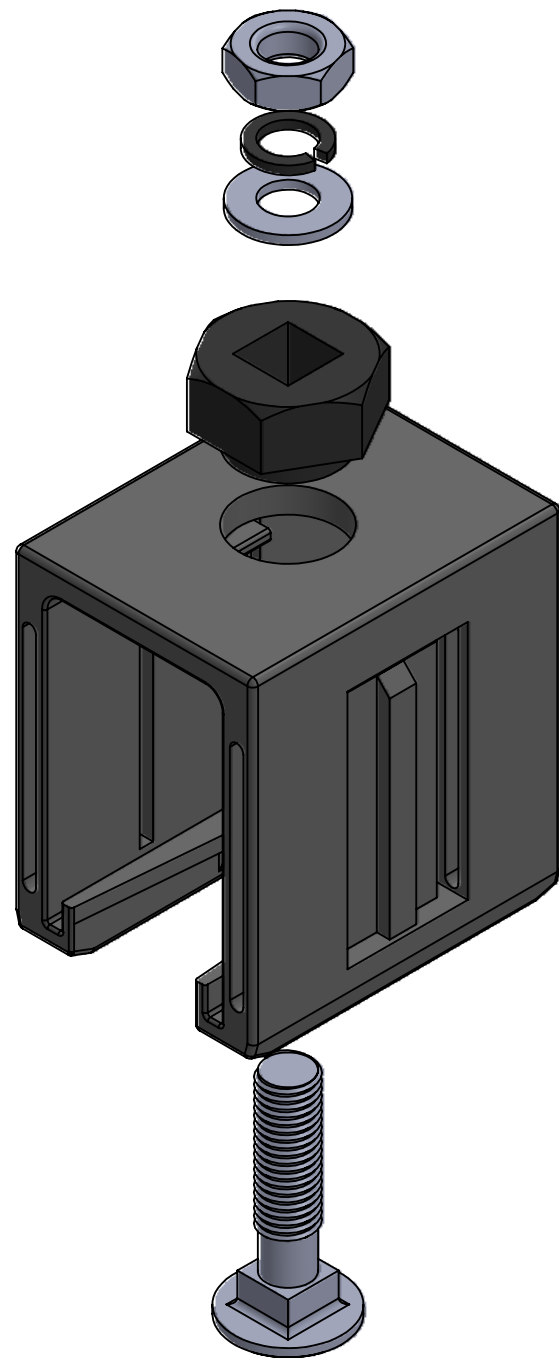

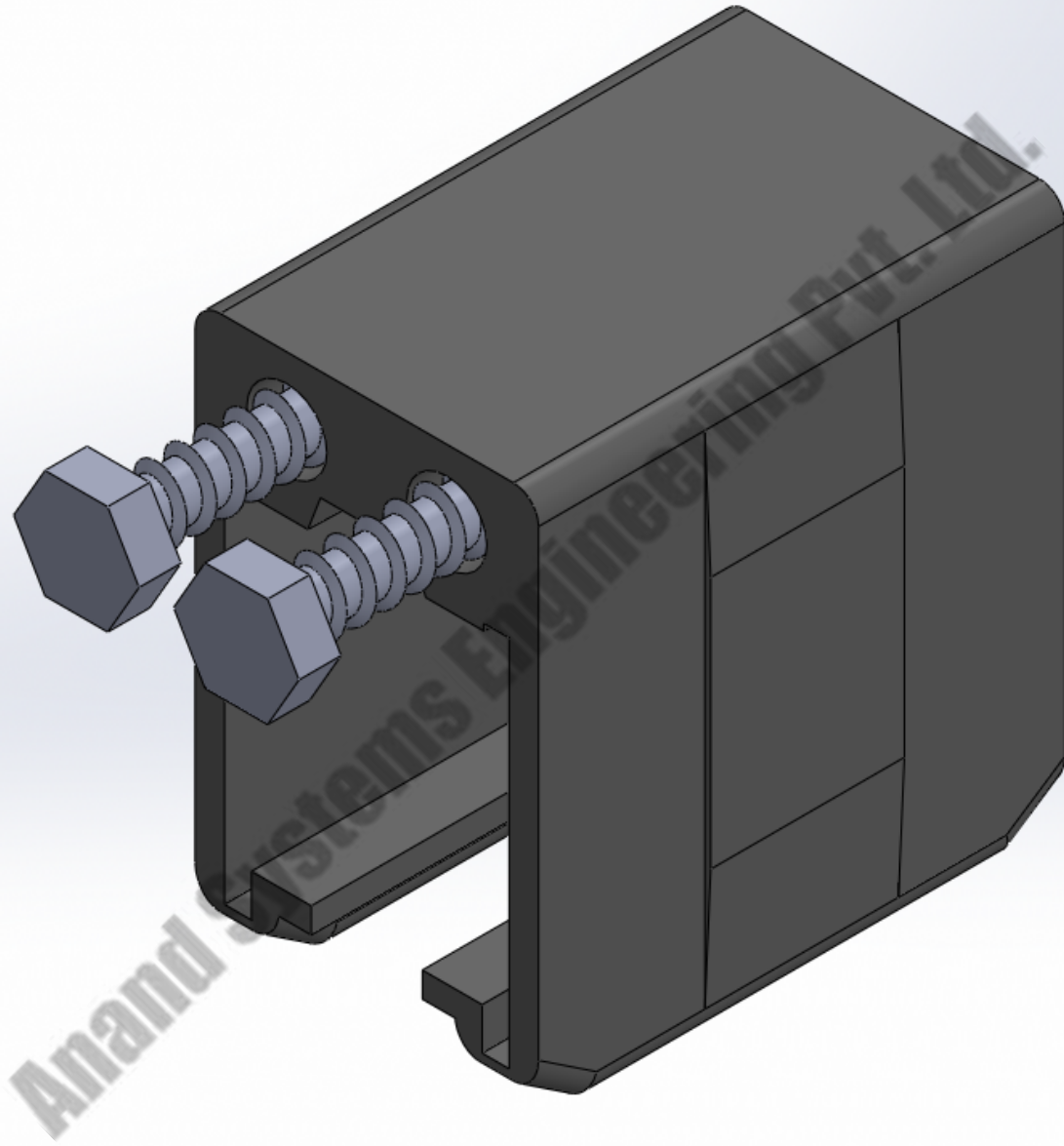

Anand Systems Engineering Pvt. Ltd.

COMPANY NAME: ANAND SYSTEM ENGINEERING PVT LTD		DO NOT SCALE DRAWING. REVISION:
Email id: info@anandcontrol.in CONTACT NO: 9137620579		SINGLE POLE HANGER CLAMP V TYPE ASSM 2D
DRAWN: SAURABH MATERIAL: CHK'D: APPVD: MFC:		DWG NO. DATE: SIGNATURE:
WEIGHT:		SCALE: SHEET: 1 OF 1

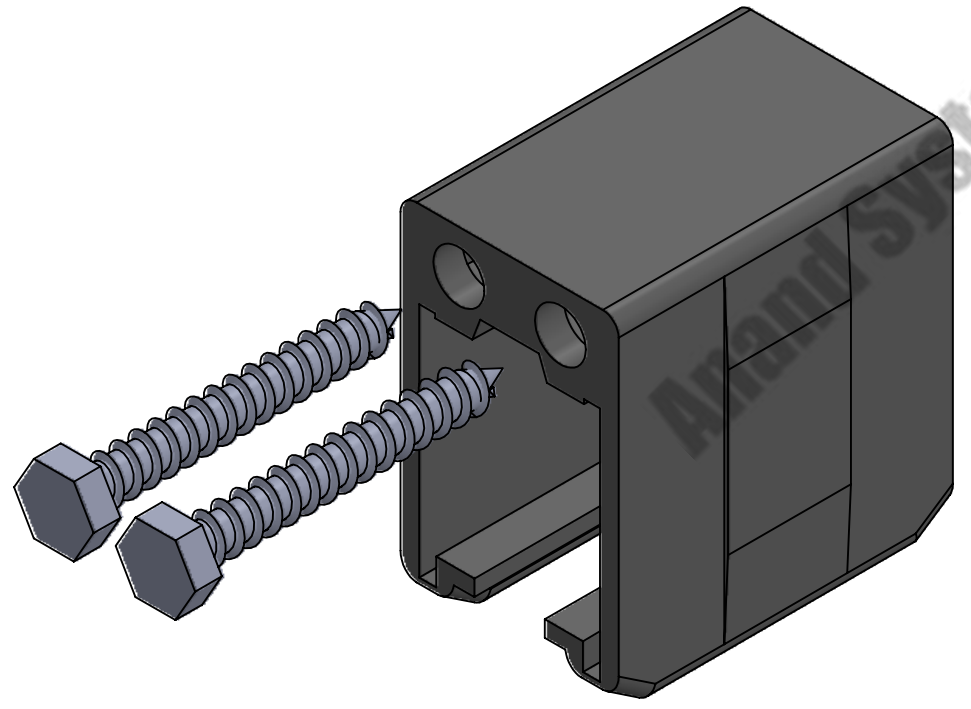
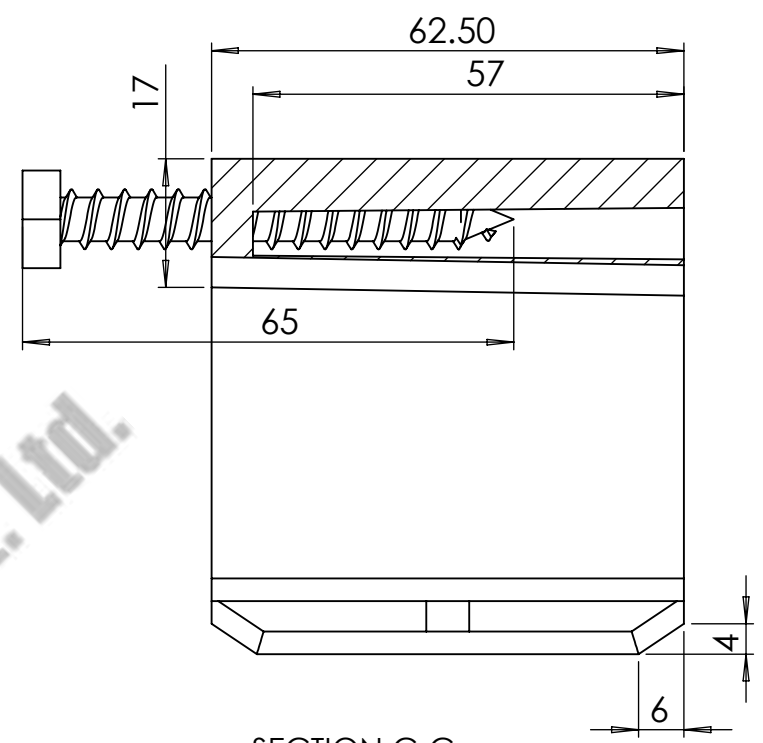
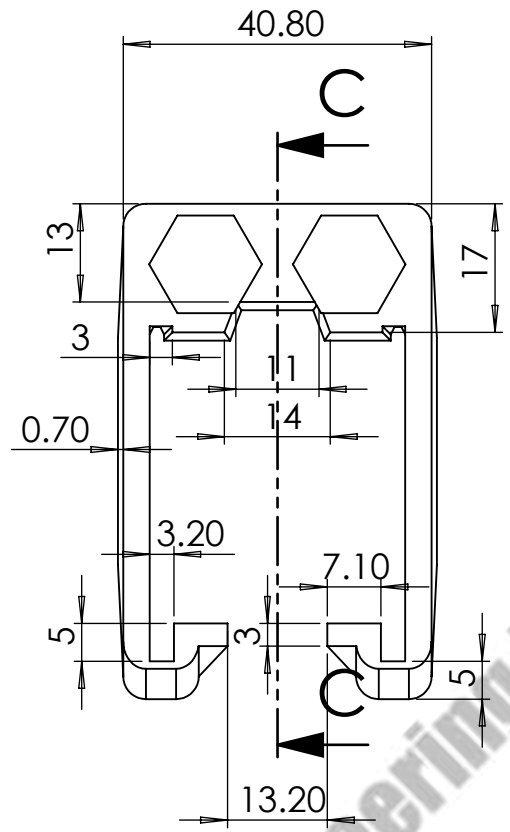
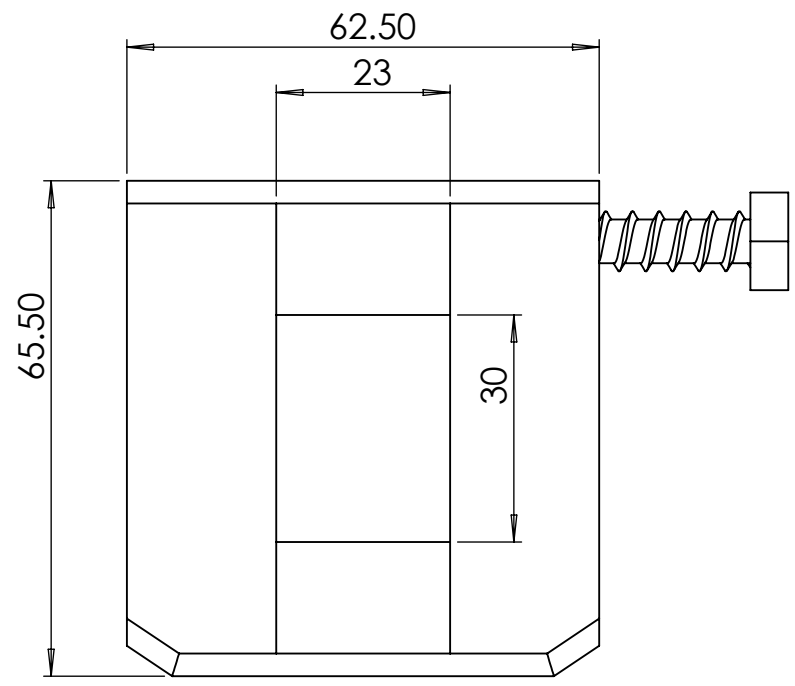



COMPANY NAME:		ANAND SYSTEM ENGINEERING PVT LTD		DO NOT SCALE DRAWING.	REVISION:
		<p>Email id: info@anandcontrol.in</p> <p>CONTACT NO: 9137620579</p>		<p>TITLE:</p> <p>ANCHOR CLAMP ASSM V-TYPE 2D</p>	
FINISH:		MATERIAL:		DWG NO.	
DRAWN: SAURABH		MATERIAL:		DATE:	
CHK'D:		MATERIAL:		SIGNATURE:	
APPY'D:		WEIGHT:		SCALE:	
MFG:		WEIGHT:		SHEET: 1 OF 1	

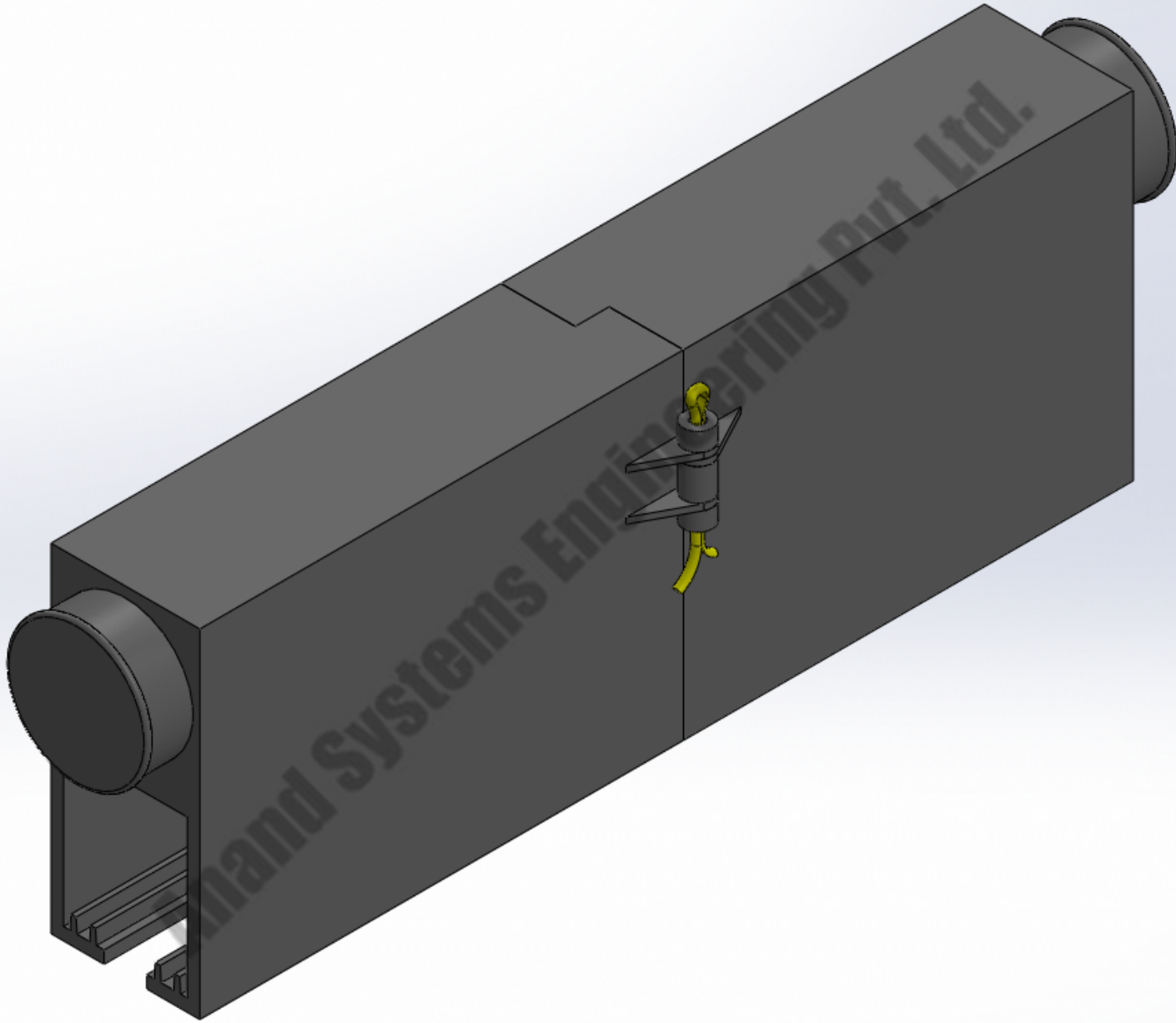

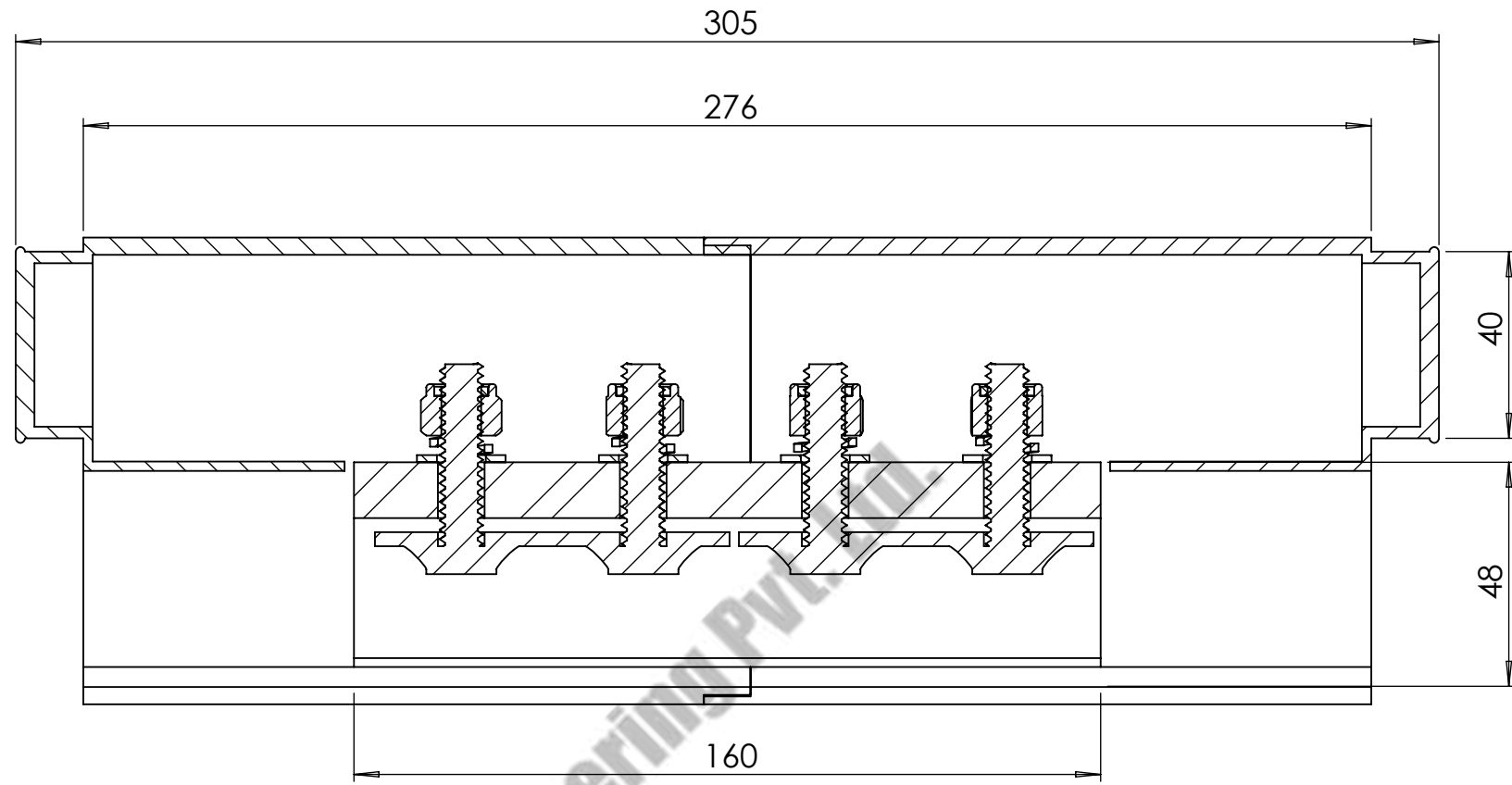
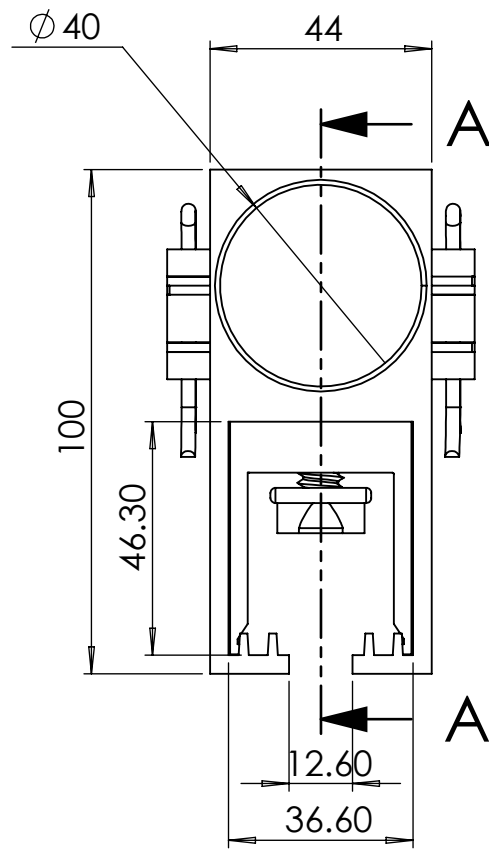

SECTION A-A
SCALE 1 : 1.5

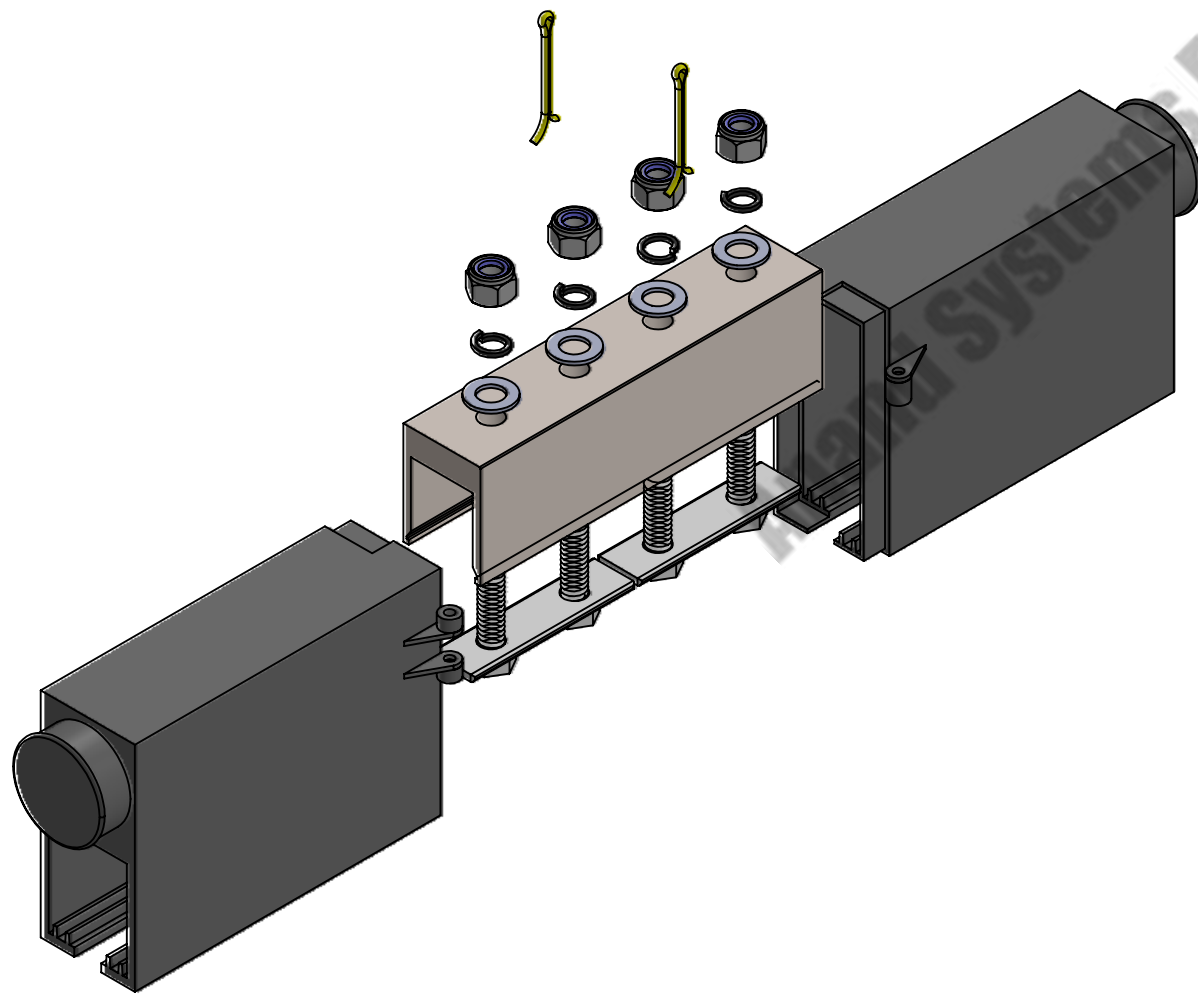

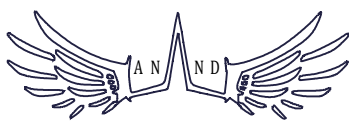
COMPANY NAME:		ANAND SYSTEM ENGINEERING PVT LTD		DO NOT SCALE DRAWING.	REVISION:
		<p>ANAND SYSTEM ENGINEERING PVT LTD</p>		TITLE: CENTRE FEED ASSEMBLY V-TYPE 2D	
Email id: info@anandcontrol.in		FINISH:		DWG NO.	
CONTACT NO: 9137620579				DATE:	
DRAWN	SAURABH			SIGNATURE:	
CHK'D				A	
APP'VD					
MFG				SCALE:	
		WEIGHT:		SHEET: 1 OF 1	

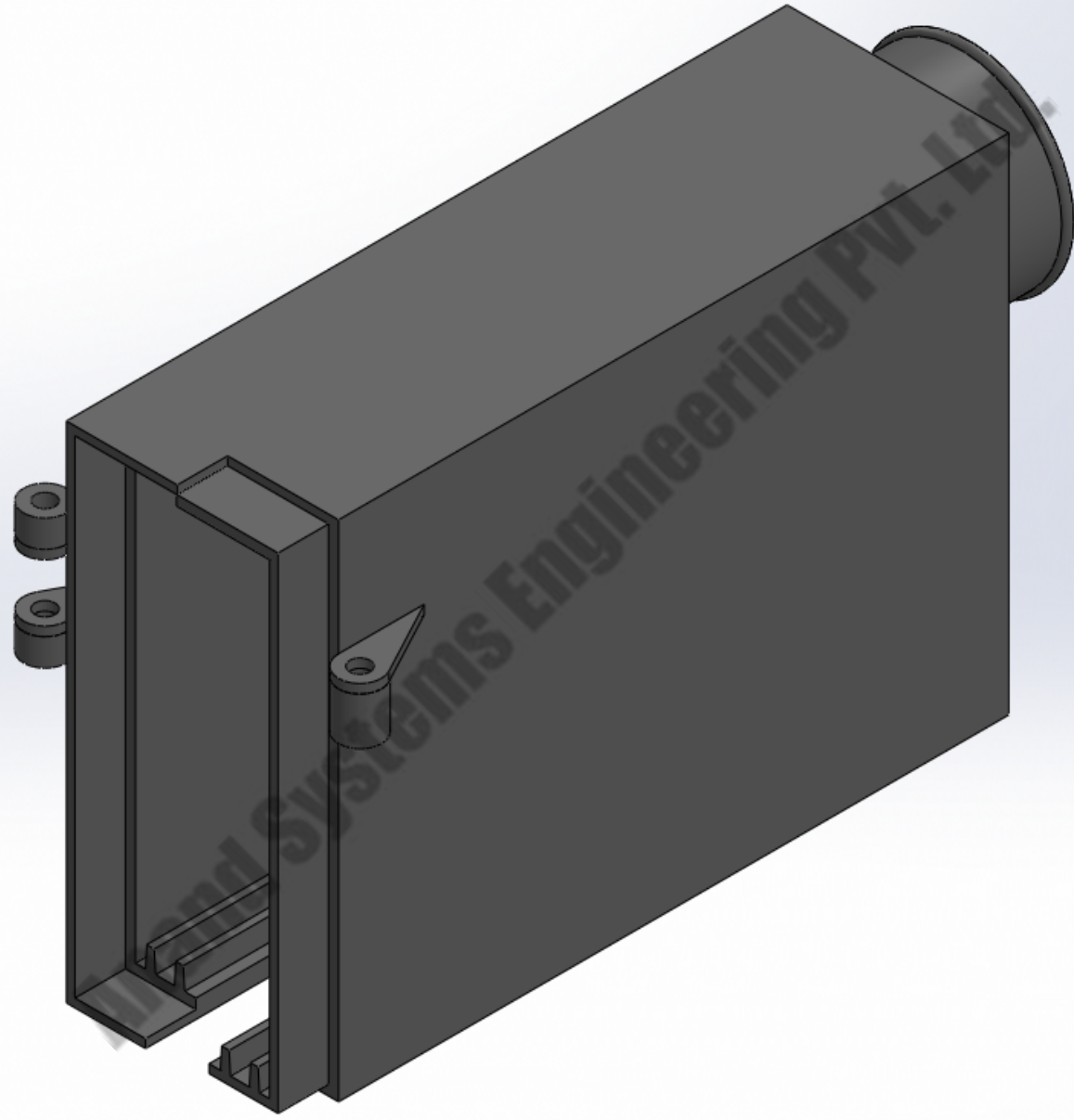

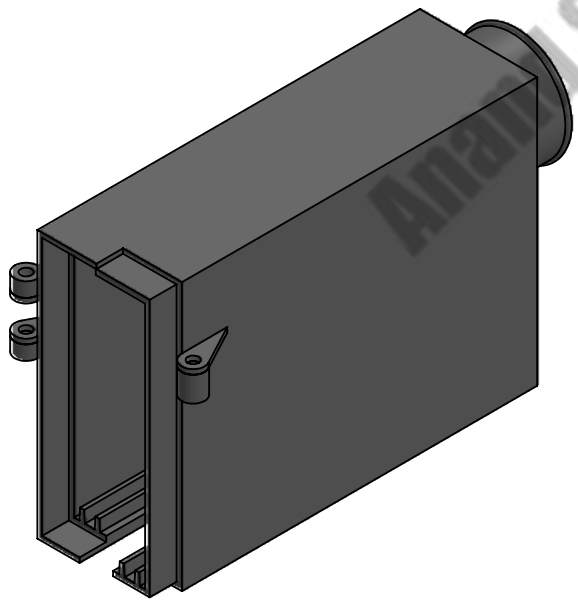
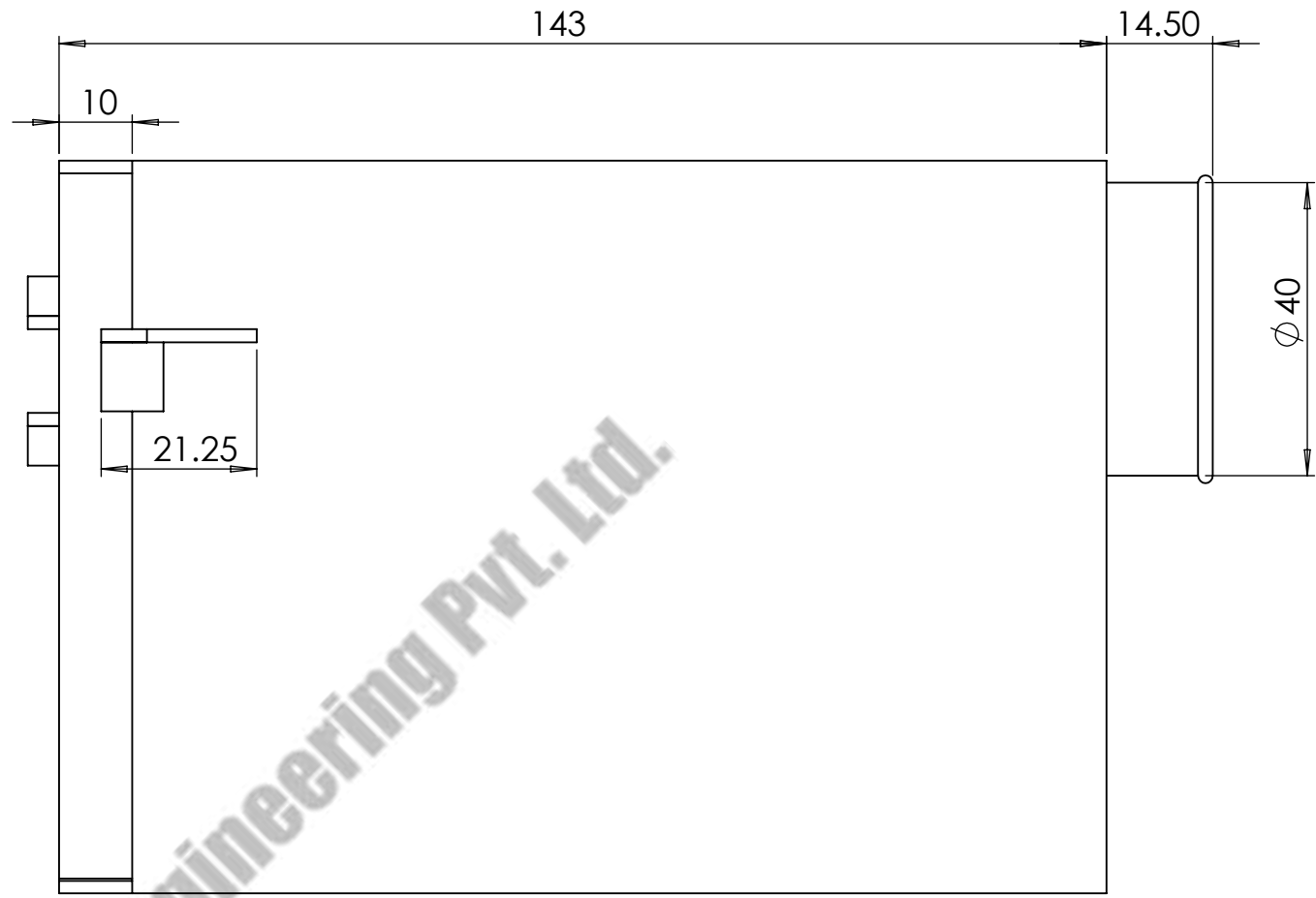
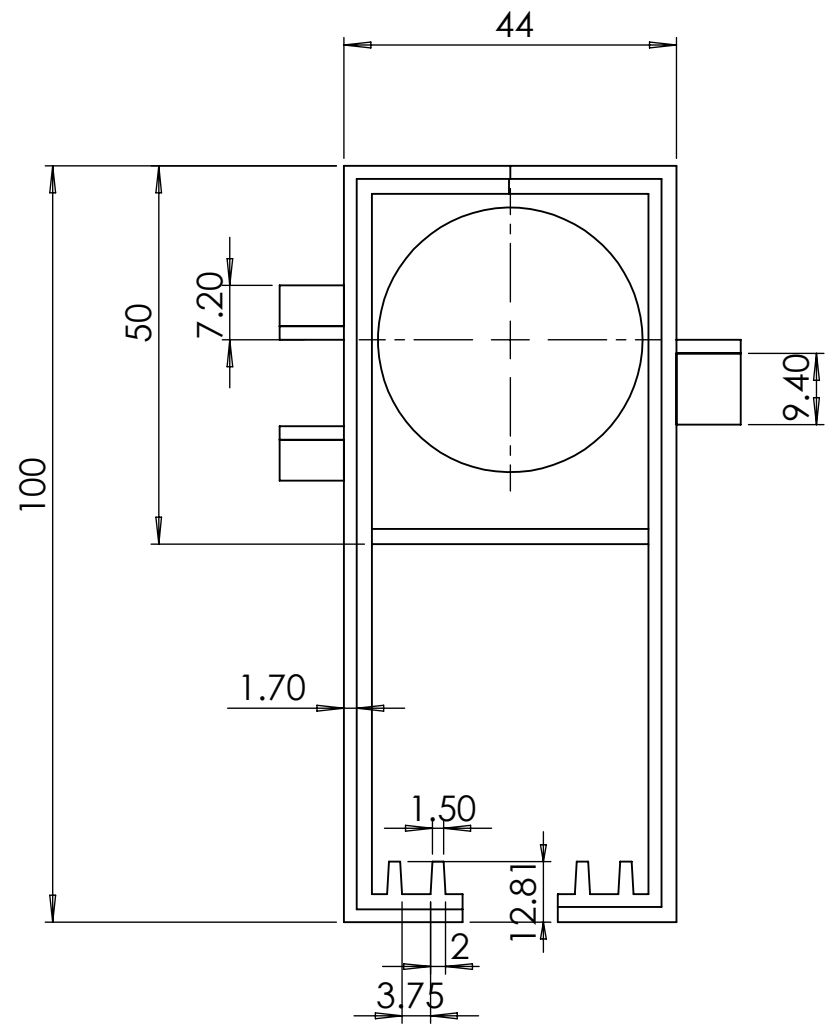

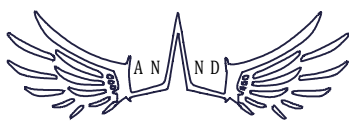

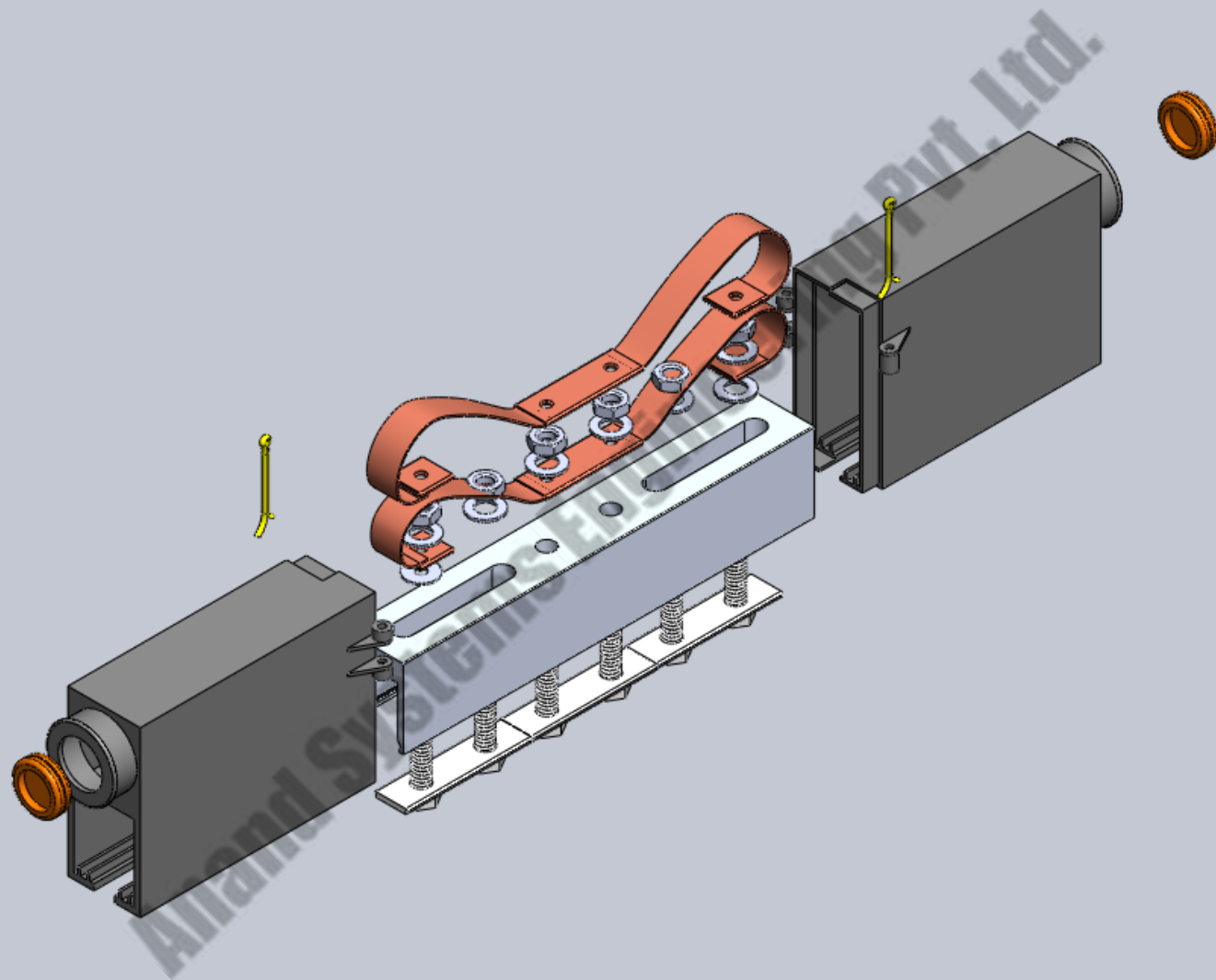
COMPANY NAME:		ANAND SYSTEM ENGINEERING PVT LTD		DO NOT SCALE DRAWING.	REVISION:
		Email id: info@anandcontrol.in CONTACT NO: 9137620579		TITLE: CENTRE POWER FEED COVER V TYPE 2D	
FINISH:		MATERIAL:		DWG NO.	
DATE:		SIGNATURE:		A	
DRAWN	SAURABH			SCALE:	
CHK'D				SHEET: 1 OF 1	
APPY'D					
MFG					

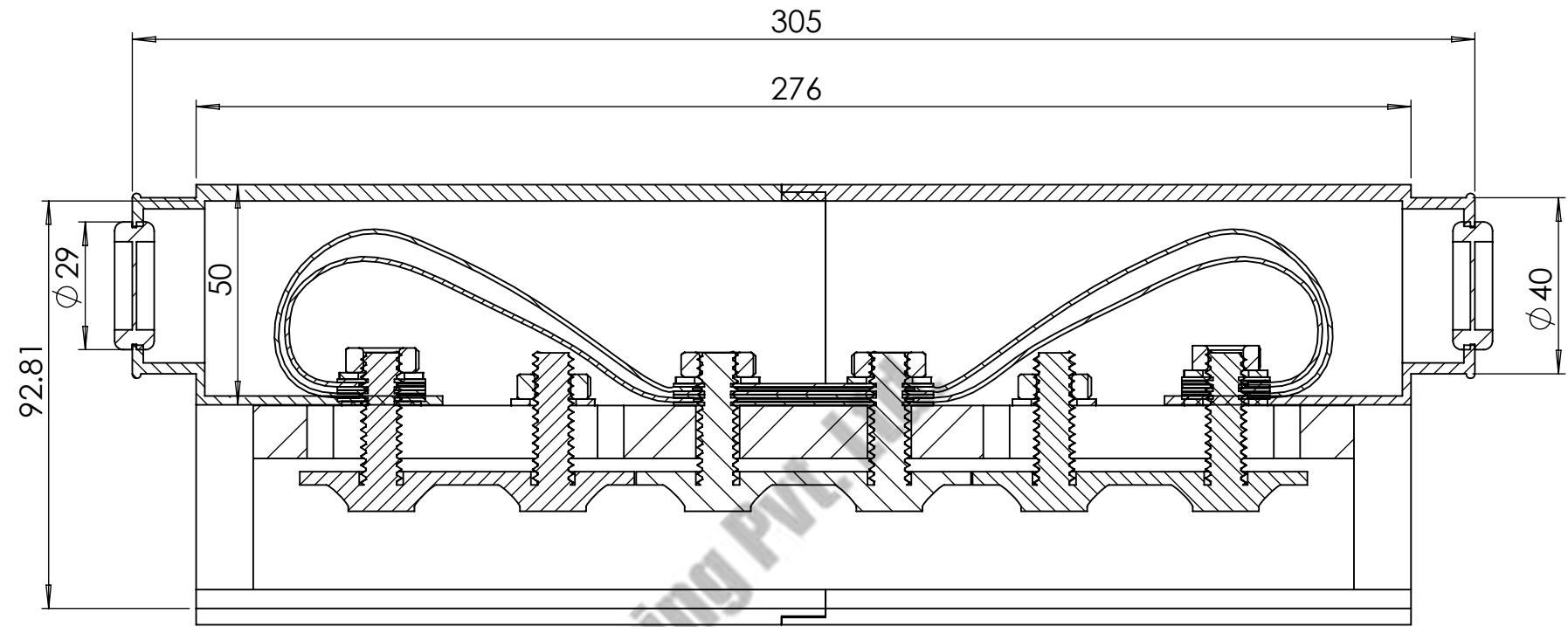
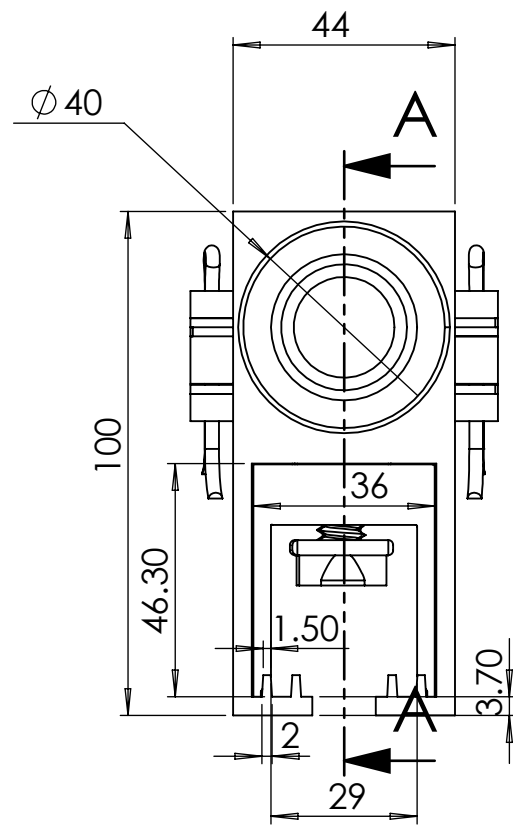

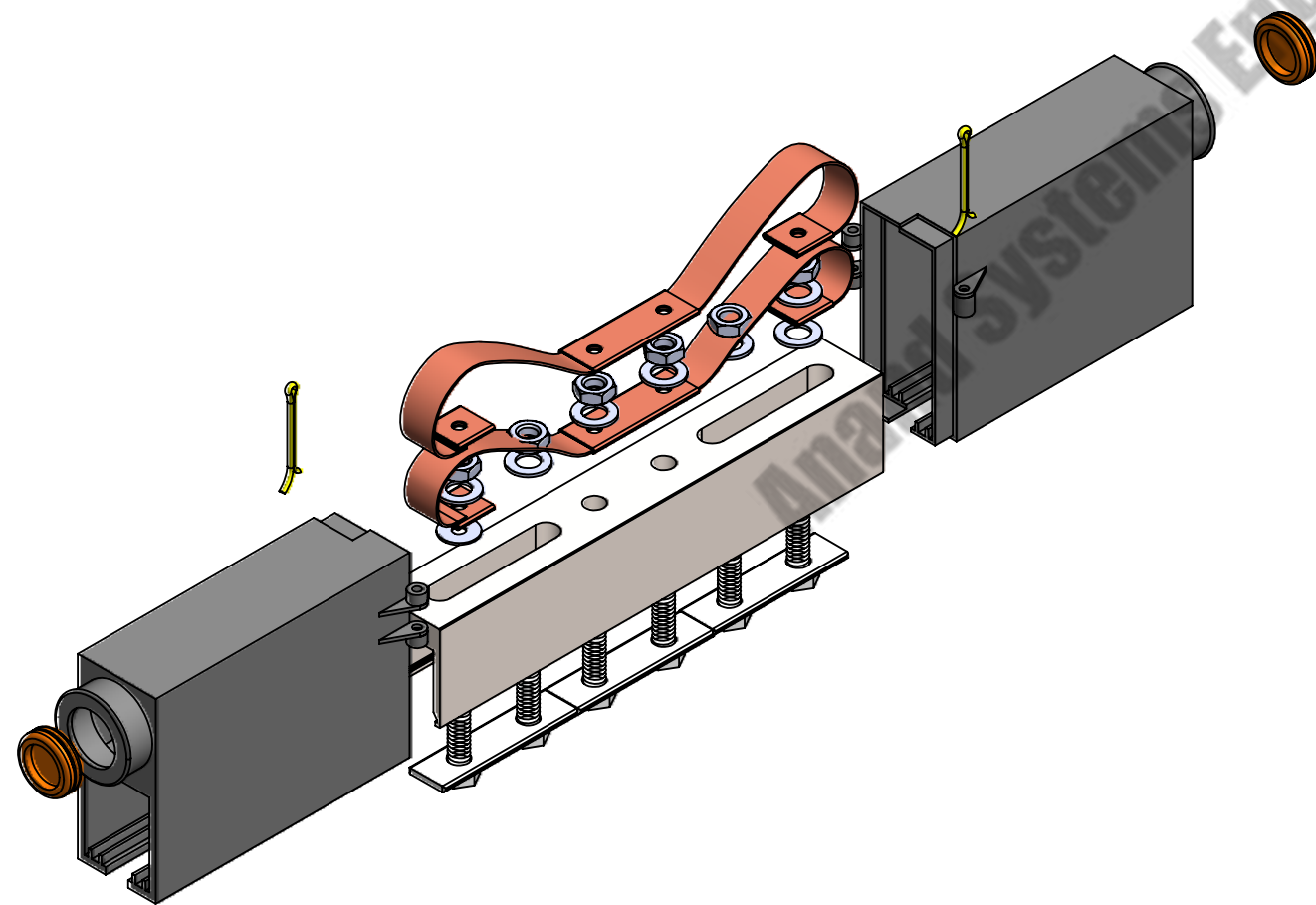

SECTION A-A
SCALE 1 : 1.5



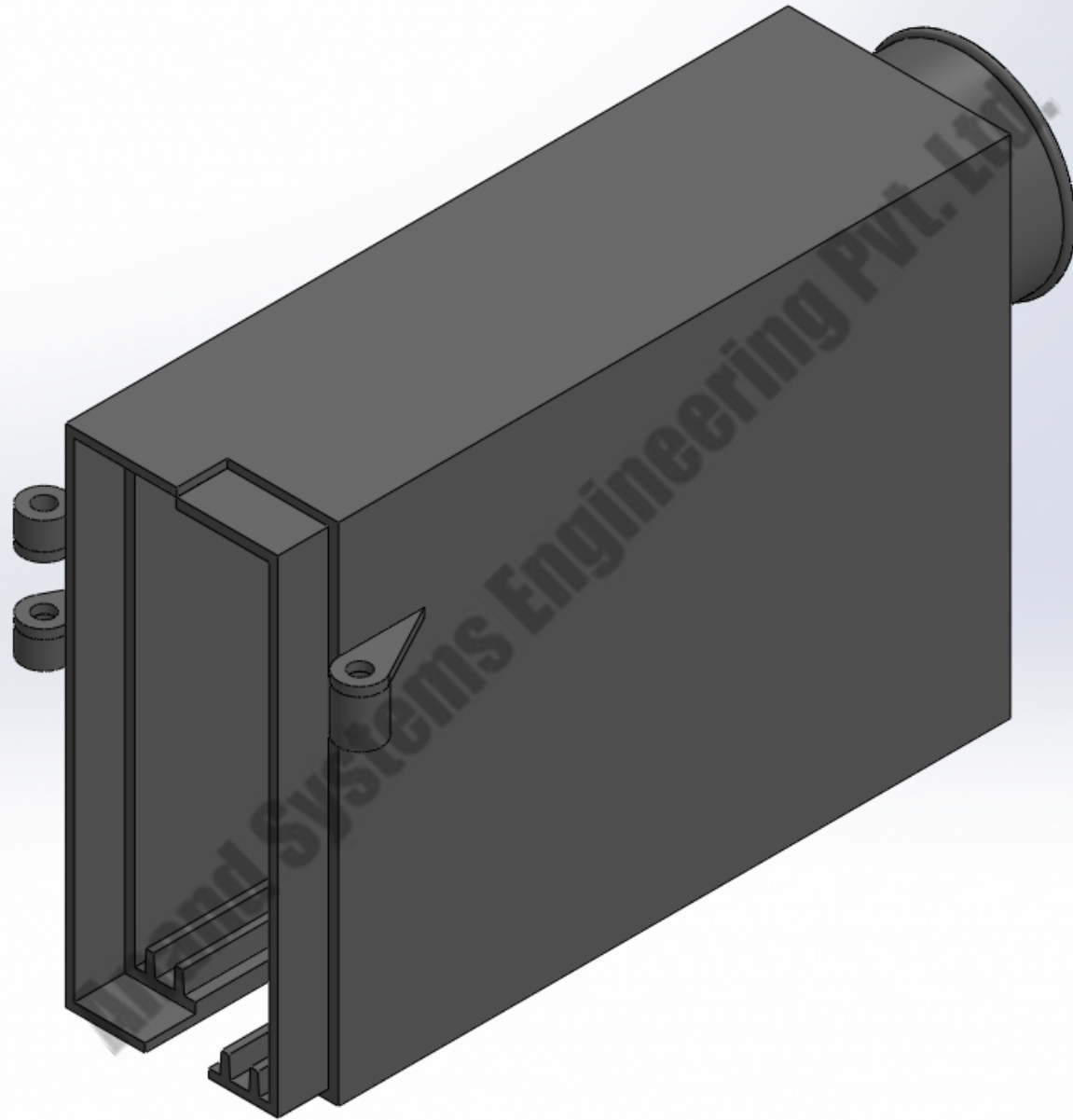

COMPANY NAME:		ANAND SYSTEM ENGINEERING PVT LTD		DO NOT SCALE DRAWING.	REVISION:
		<p>ANAND SYSTEM ENGINEERING PVT LTD</p>		TITLE:	
Email id: info@anandcontrol.in		FINISH:		EXPANSION JOINT ASSEMBLY V-TYPE 2D	
CONTACT NO: 9137620579				DWG NO.	
DRAWN	SAURABH			DATE:	SIGNATURE:
CHK'D					
APP'VD					
MFG				SCALE:	SHEET: 1 OF 1
				A	

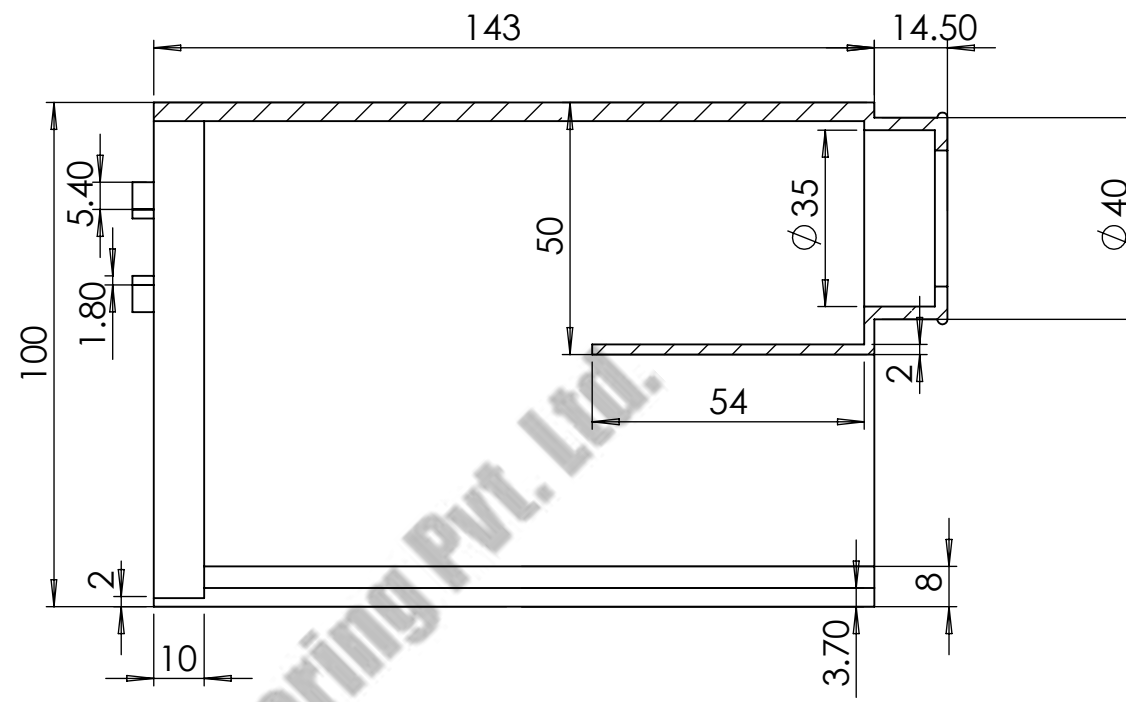
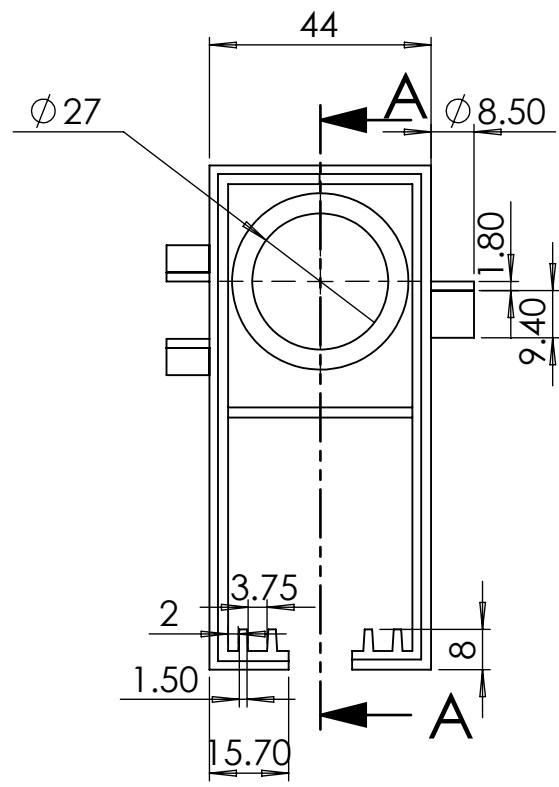



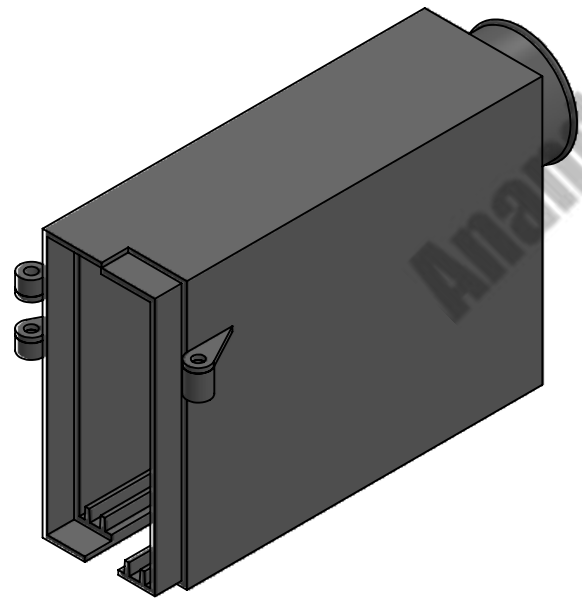

SECTION A-A
SCALE 1 : 1.5

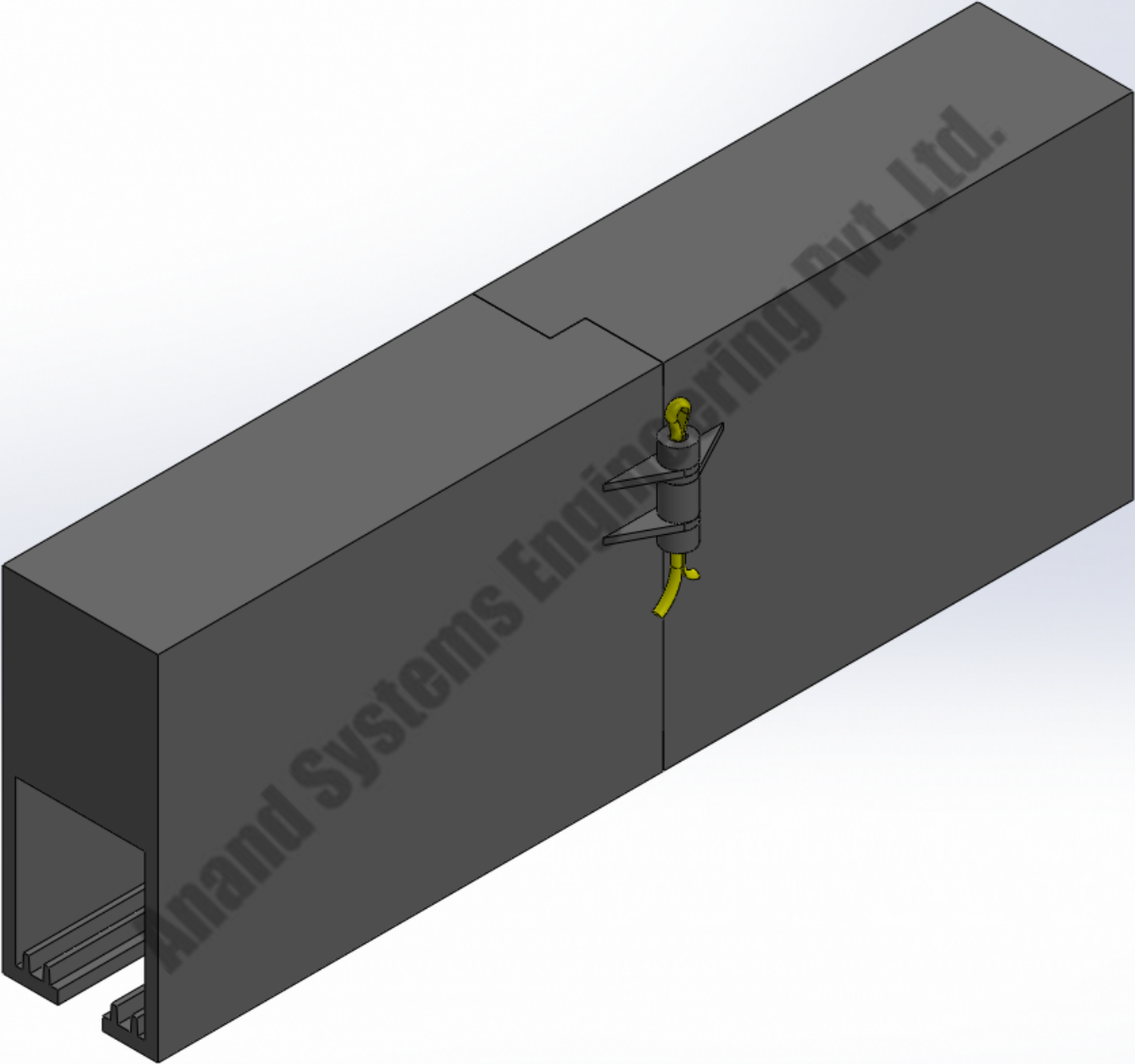

COMPANY NAME:		ANAND SYSTEM ENGINEERING PVT LTD		DO NOT SCALE DRAWING.	REVISION:
		<p>ANAND SYSTEM ENGINEERING PVT LTD</p>		TITLE: EXPANSION JOINT COVER V TYPE 2D	
Email id: info@anandcontrol.in		FINISH:		DWG NO.	
CONTACT NO: 9137620579				DATE:	
DRAWN	SAURABH			SIGNATURE:	
CHK'D				A	
APP'VD					
MFG				SCALE:	
		WEIGHT:		SHEET: 1 OF 1	

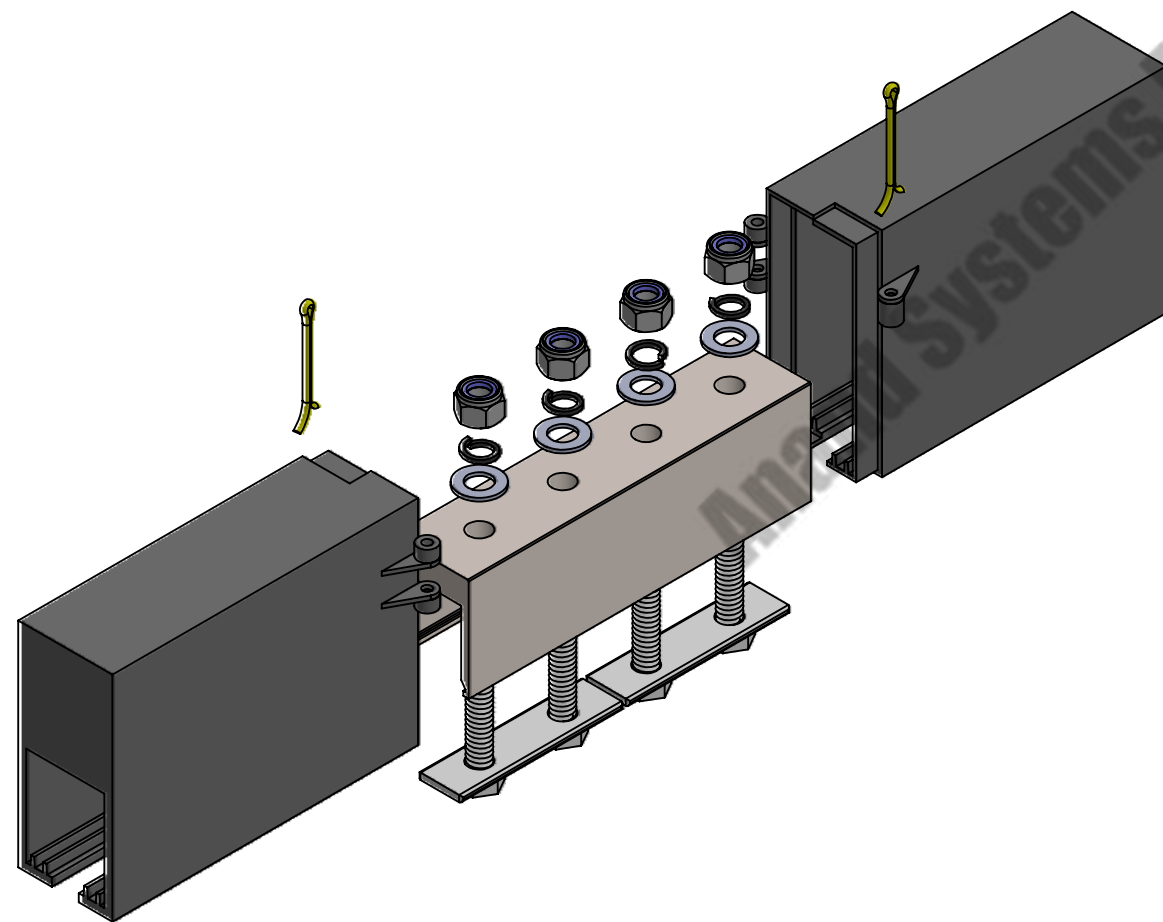
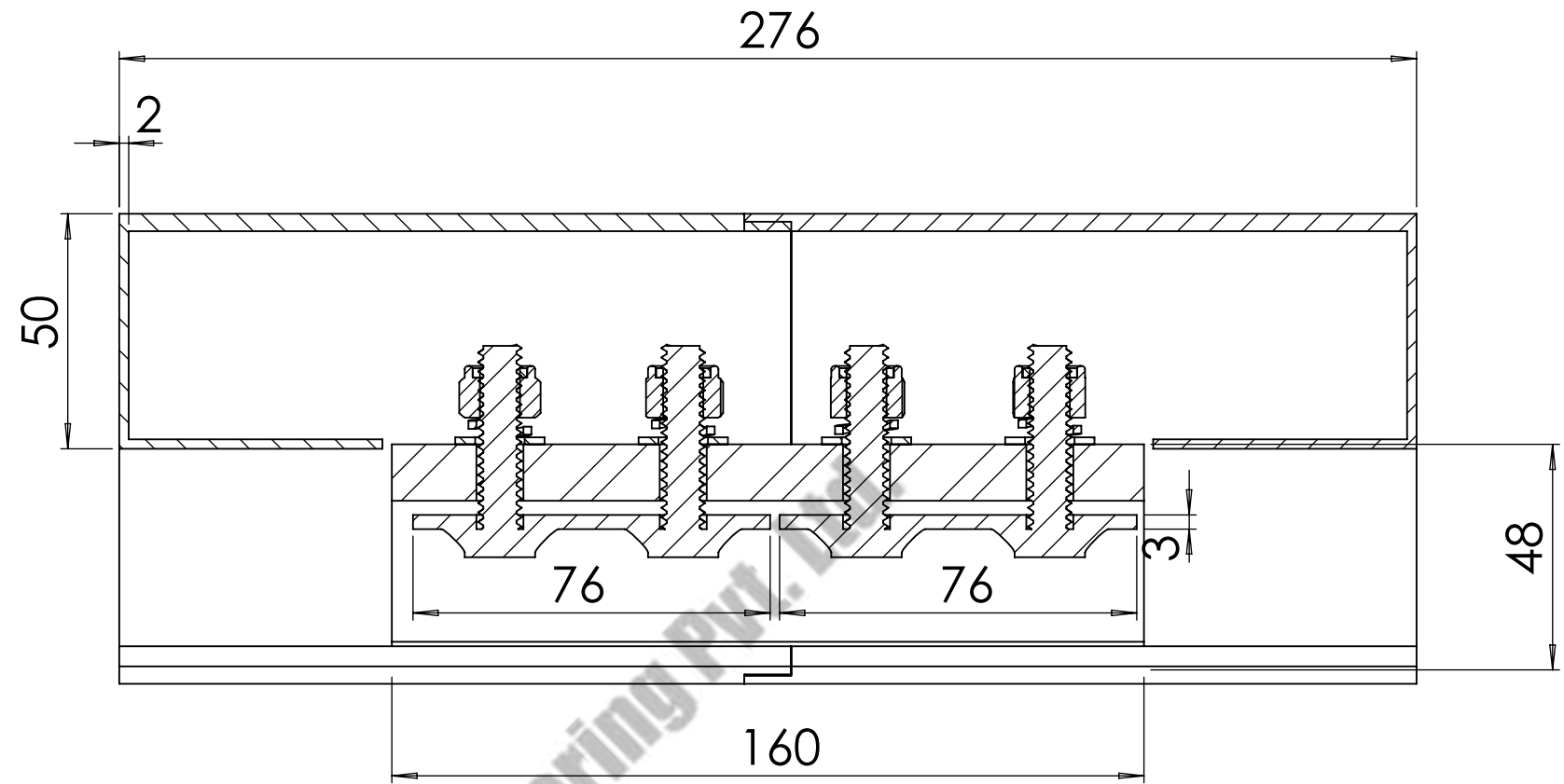
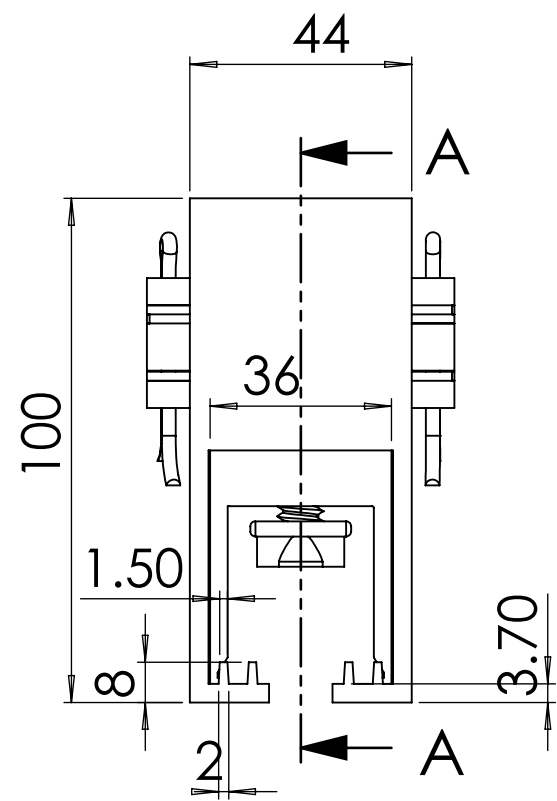



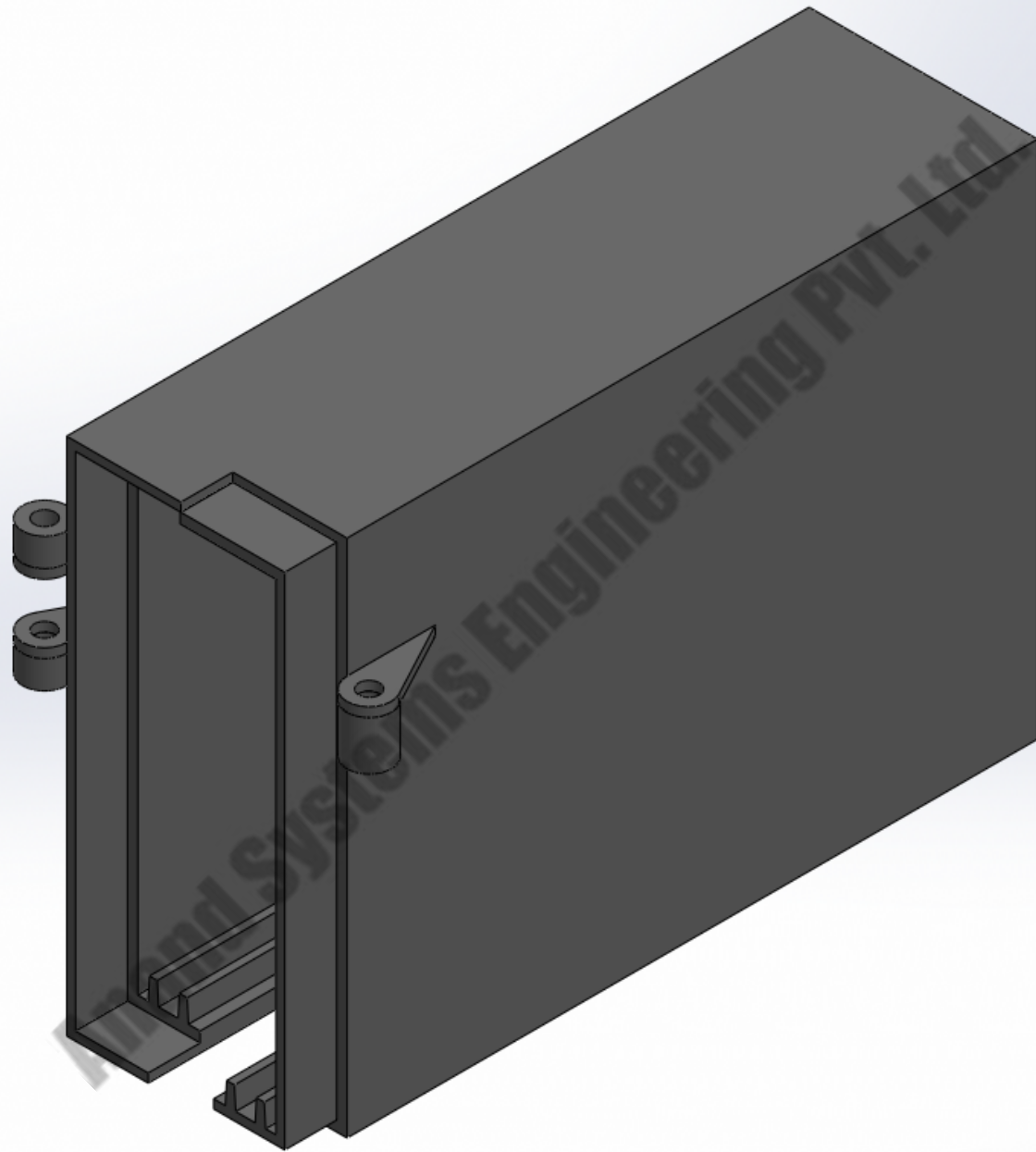

COMPANY NAME:		ANAND SYSTEM ENGINEERING PVT LTD		DO NOT SCALE DRAWING.	REVISION:
		Email id: info@anandcontrol.in CONTACT NO: 9137620579		TITLE: JOINT CLAMP ASSEMBLY V-TYPE 2D	
FINISH:		MATERIAL:		DWG NO.	
DATE:		SIGNATURE:		A	
DRAWN	SAURABH	WEIGHT:		SCALE:	
CHK'D		SHEET: 1 OF 1			
APP'D					
MFG					

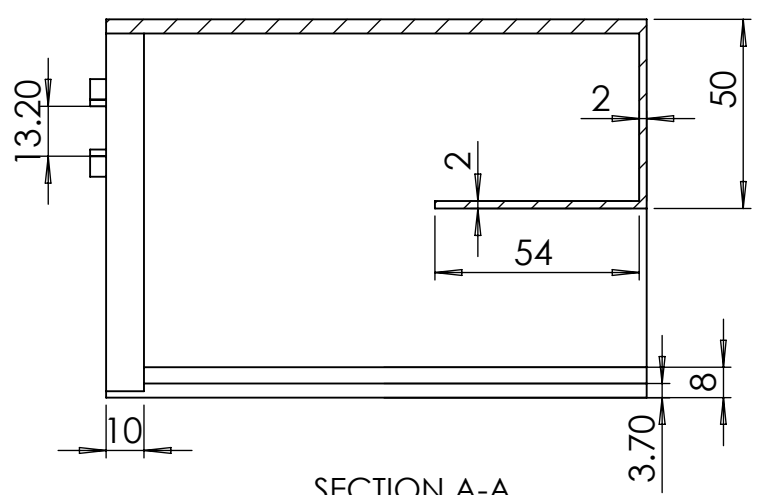

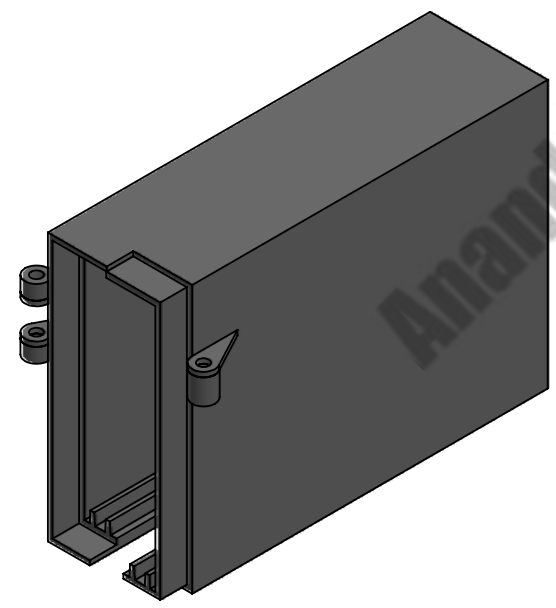
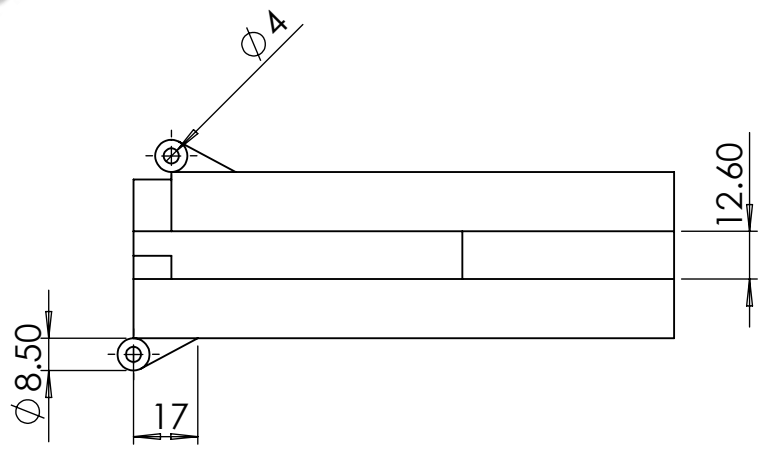
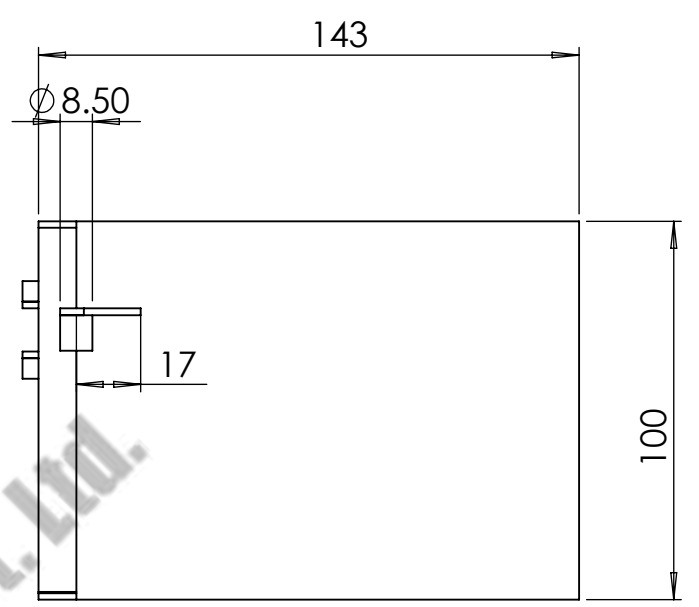
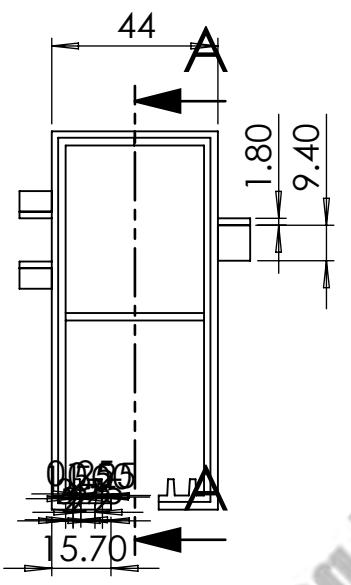

SECTION A-A



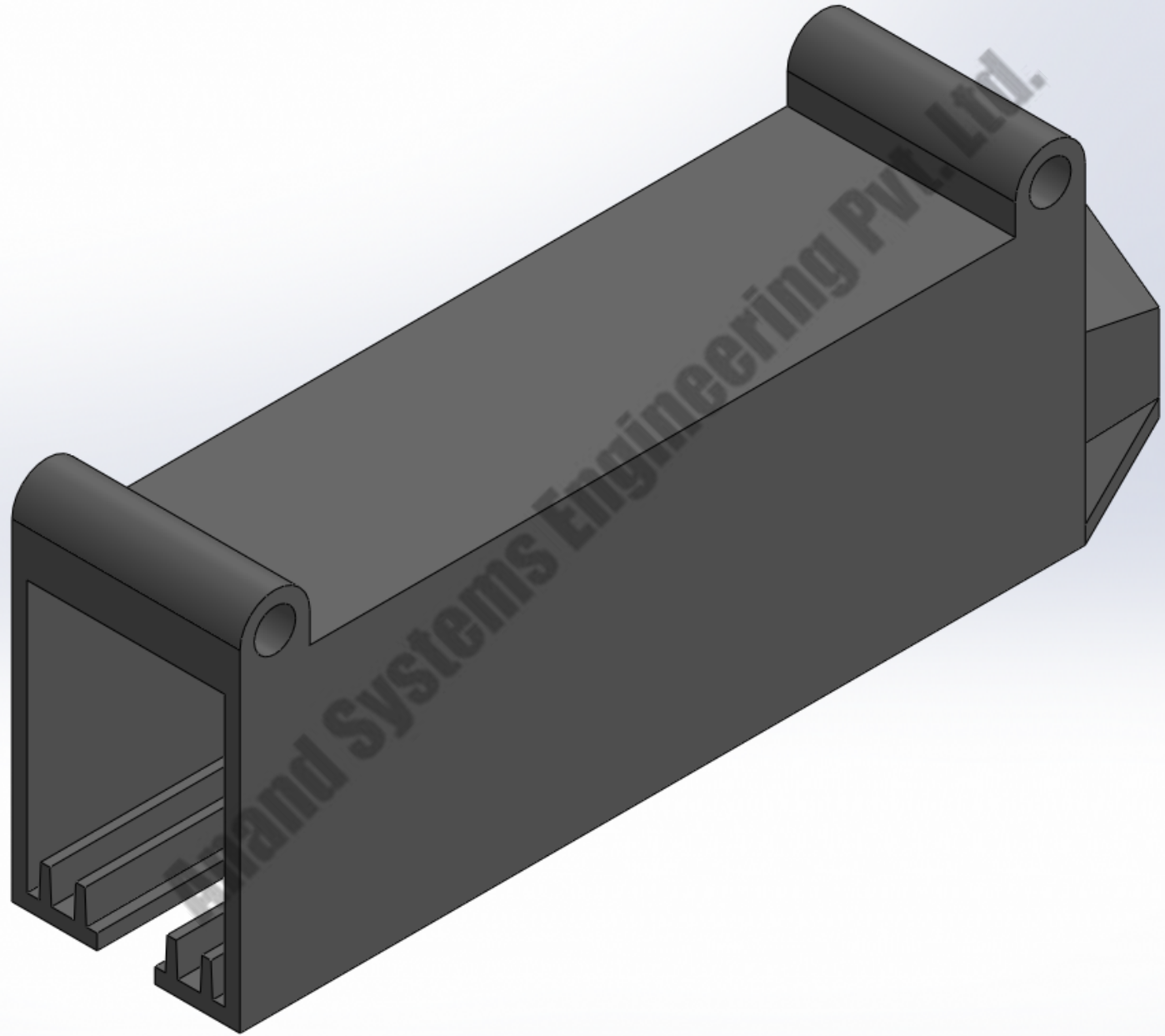

COMPANY NAME:		ANAND SYSTEM ENGINEERING PVT LTD		DO NOT SCALE DRAWING.	REVISION:
		<p>Email id: info@anandcontrol.in</p> <p>CONTACT NO: 9137620579</p>		<p>TITLE:</p> <p>JOINT COVER V TYPE 2D</p>	
FINISH:		MATERIAL: PLASTIC		<p>DWG NO.</p> <p>100X44X143</p>	
DRAWN	SAURABH			DATE:	SIGNATURE:
CHK'D				A	
APPY'D					
MFG				SCALE:	SHEET: 1 OF 1

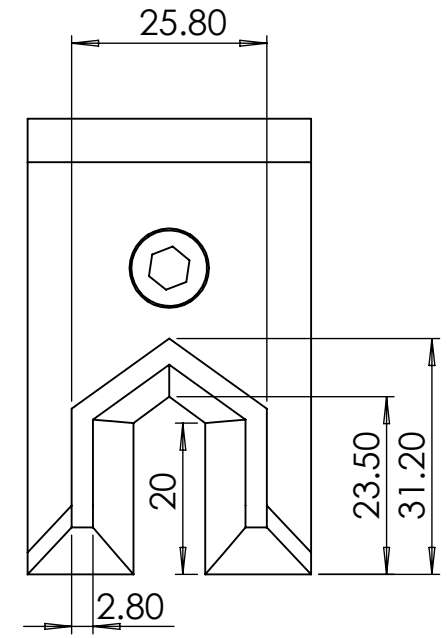
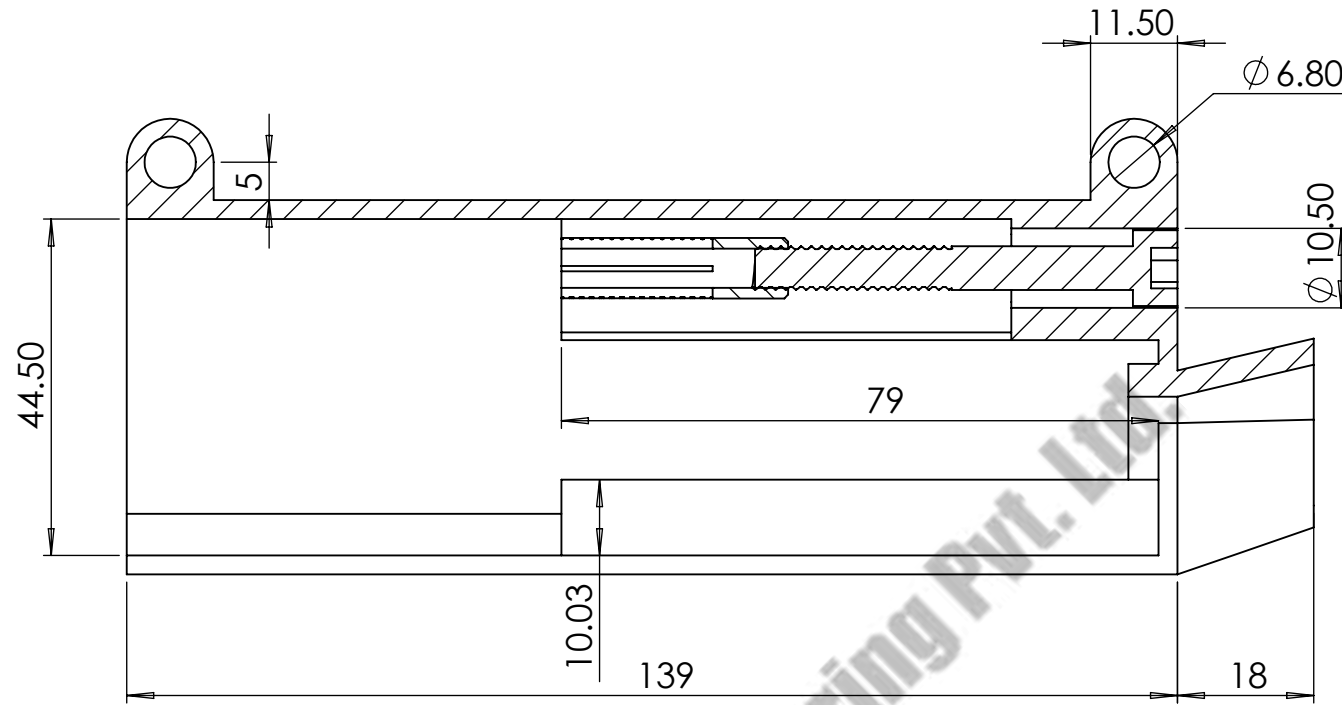
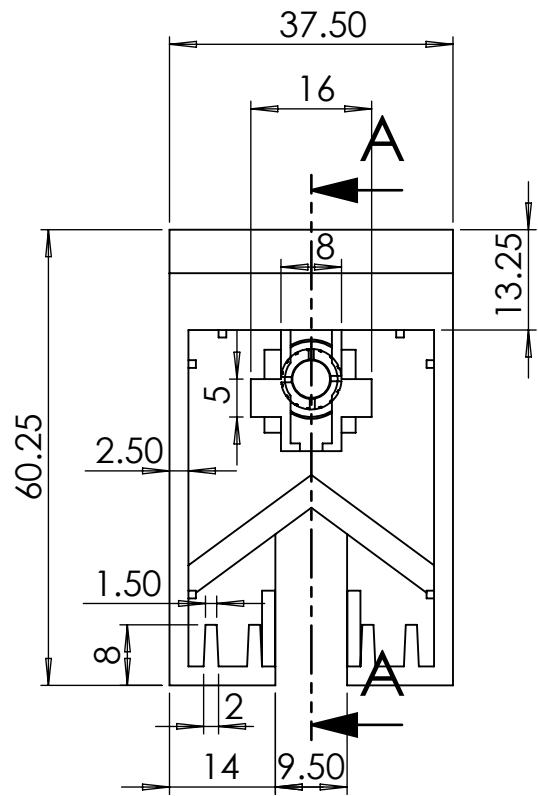

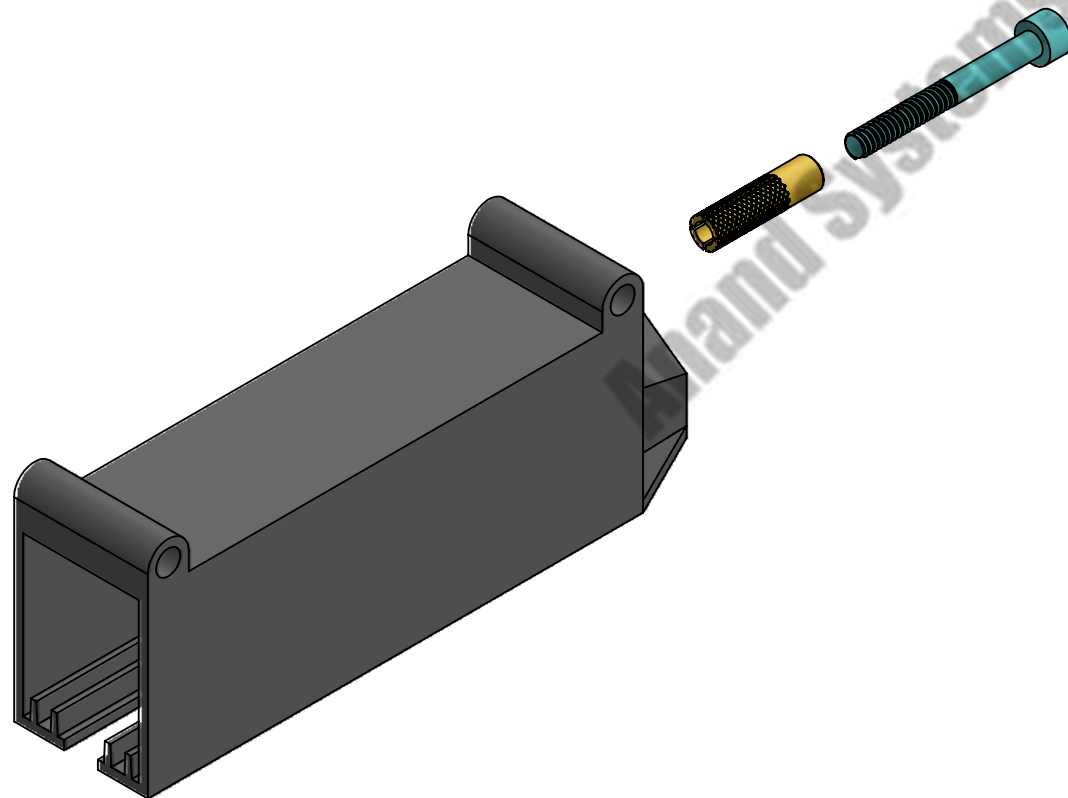

SECTION A-A
SCALE 1 : 1



COMPANY NAME:		ANAND SYSTEM ENGINEERING PVT LTD		DO NOT SCALE DRAWING.	REVISION:
		<p>ANAND SYSTEM ENGINEERING PVT LTD</p>		TITLE: END COVER V TYPE ASSM 2D	
Email id: info@anandcontrol.in		FINISH:		DWG NO.	
CONTACT NO: 9137620579				DATE:	
DRAWN	SAURABH			SIGNATURE:	
CHK'D					
APP'VD					
MFG				SCALE:	SHEET: 1 OF 1

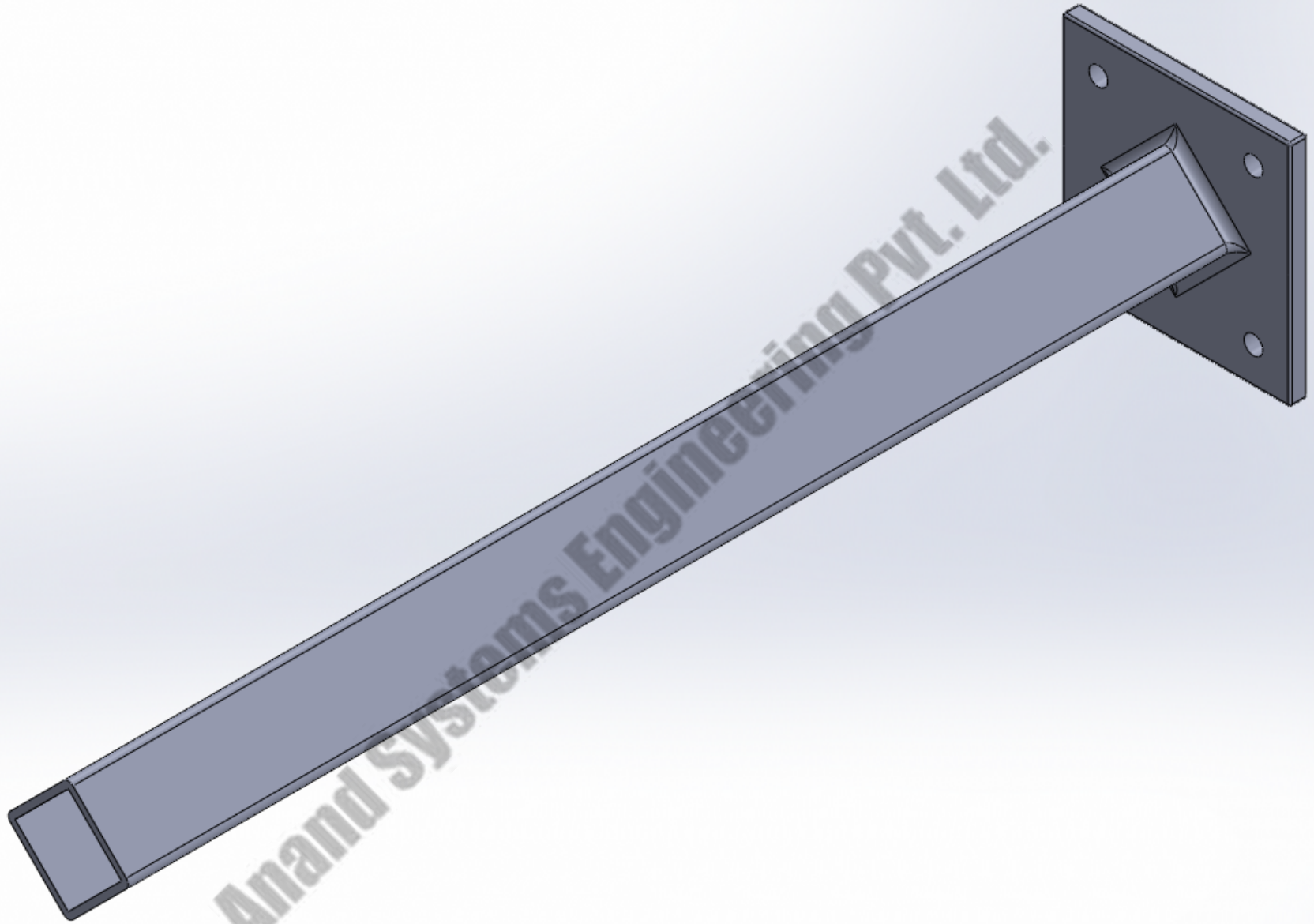

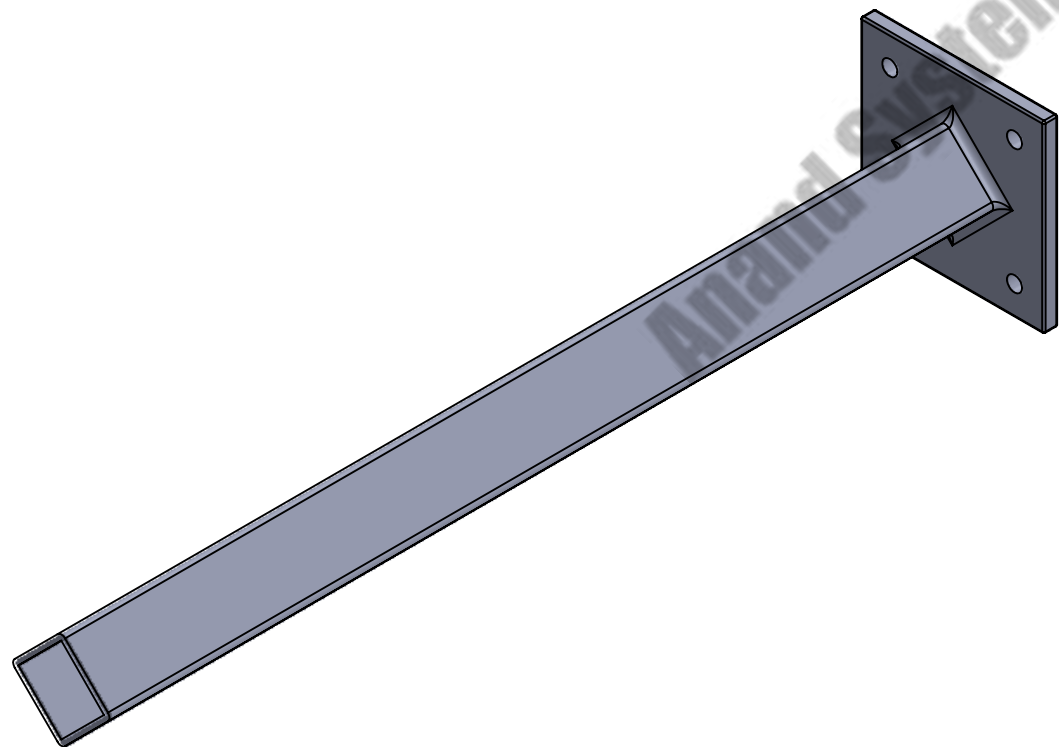
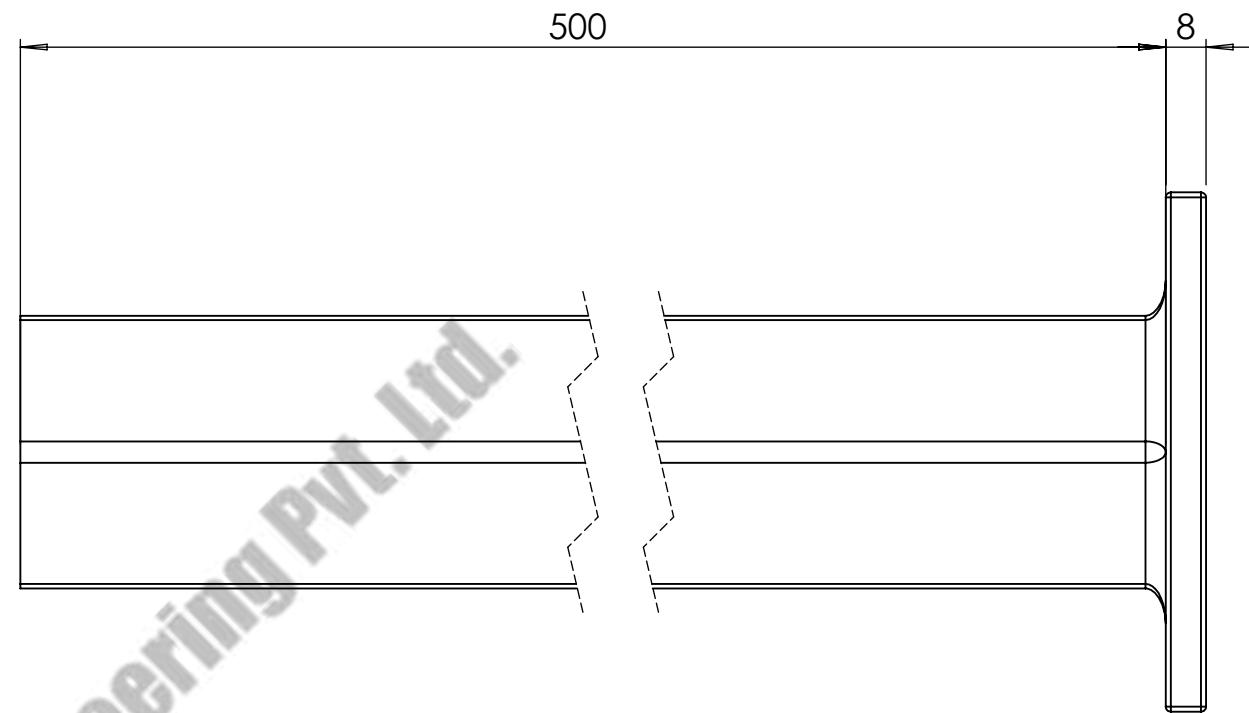
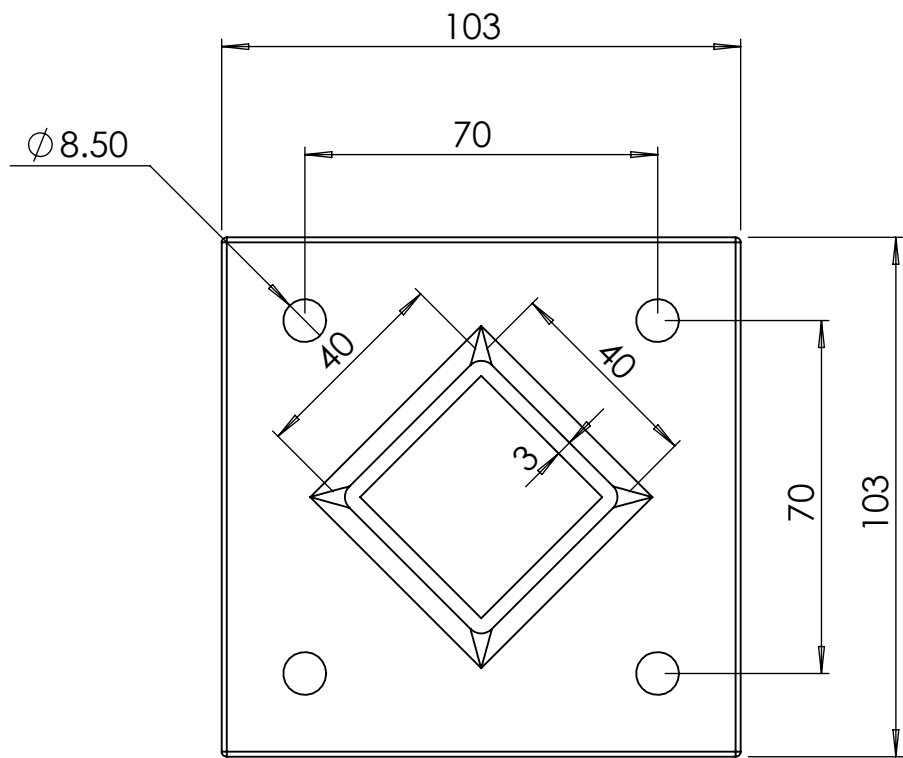

Anand Systems Engineering Pvt. Ltd.

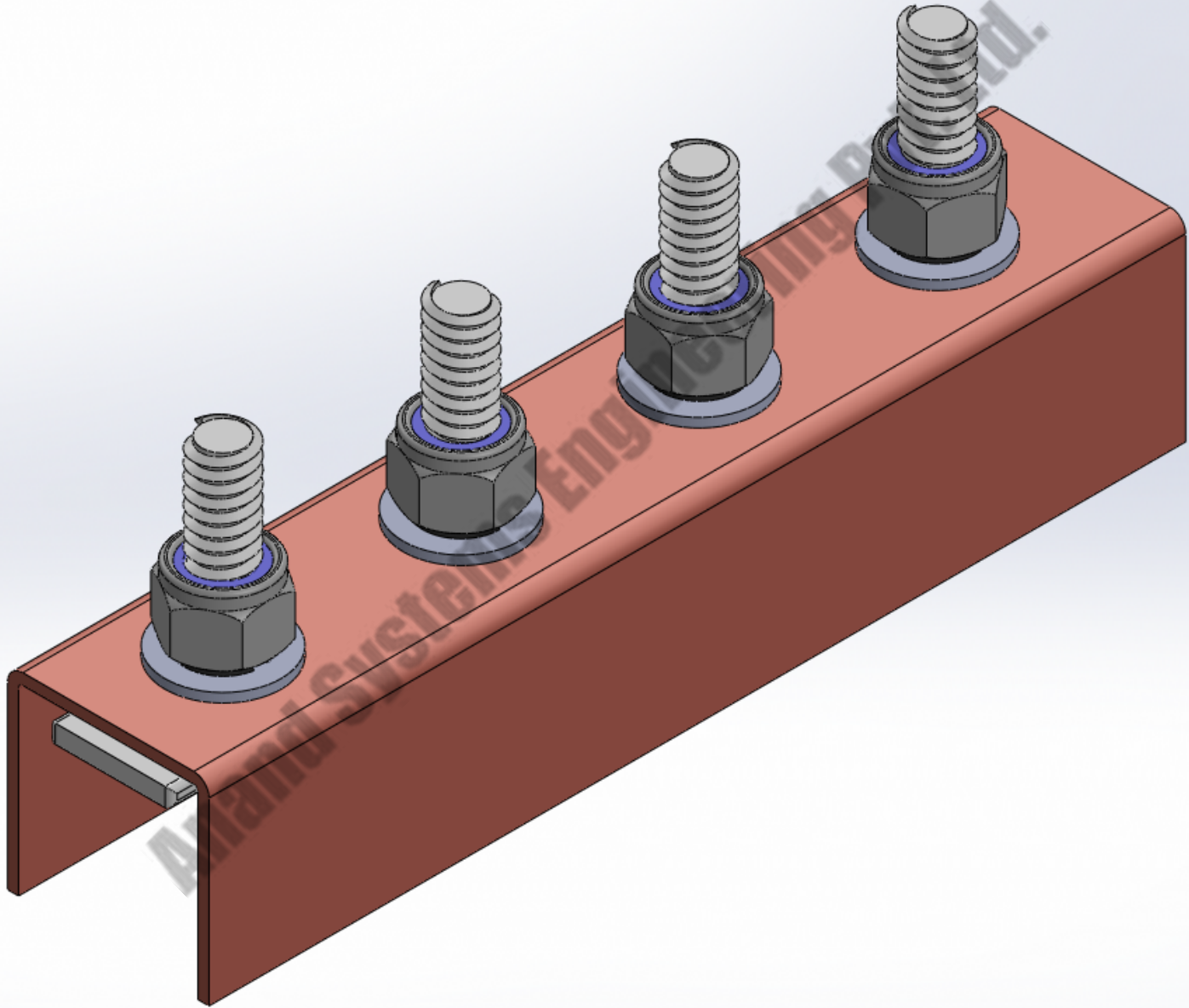

COMPANY NAME:		ANAND SYSTEM ENGINEERING PVT LTD		DO NOT SCALE DRAWING.	REVISION:
		Email id: info@anandcontrol.in CONTACT NO: 9137620579		TITLE: C.C-TOWNG BRACKET V-TYPE 2D	
FINISH:		MATERIAL:		DWG NO.	
DATE:		SIGNATURE:		A	
DRAWN	SAURABH			SCALE:	
CHK'D				SHEET: 1 OF 1	
APPY'D					
MFG					

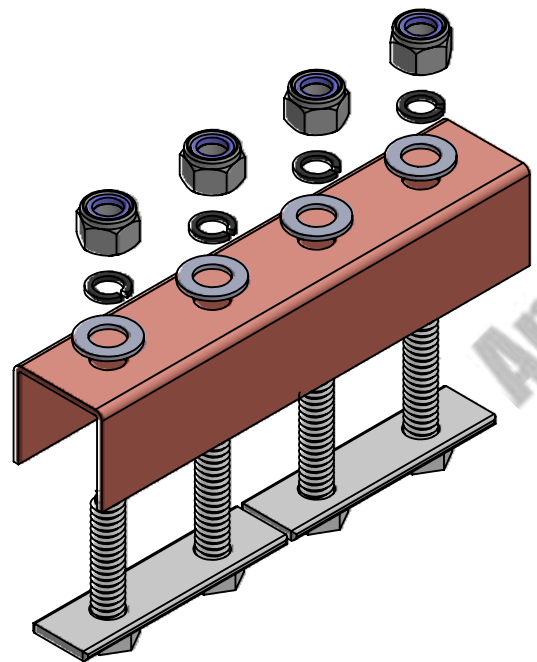
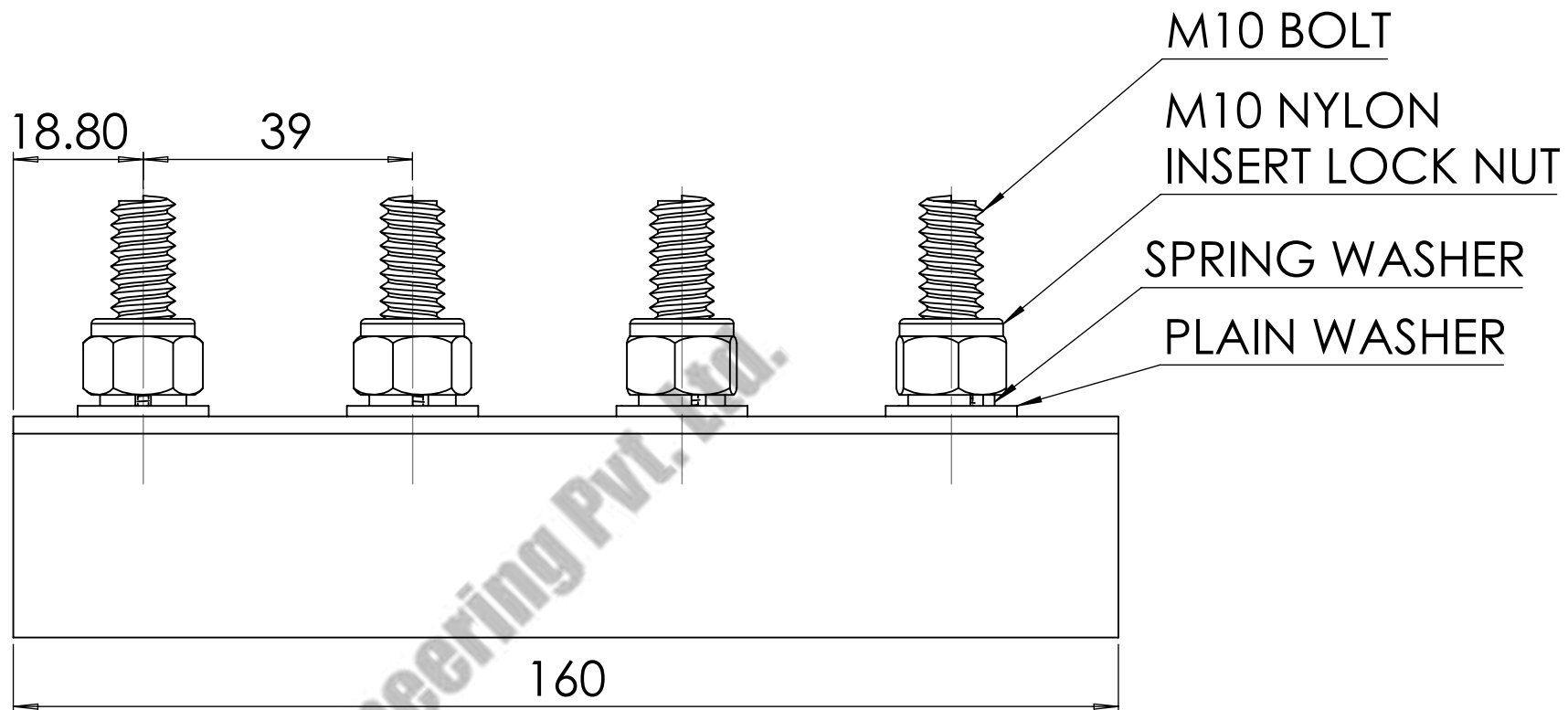
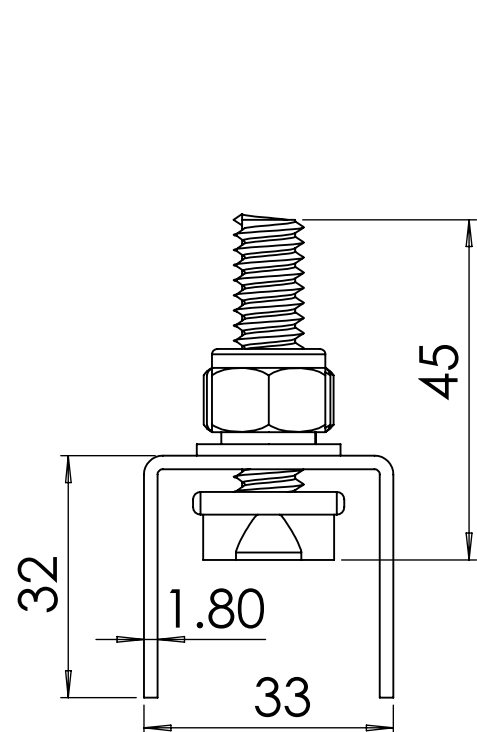



COMPANY NAME:		ANAND SYSTEM ENGINEERING PVT LTD		DO NOT SCALE DRAWING.	REVISION:
		Email id: info@anandcontrol.in CONTACT NO: 9137620579		TITLE: JOINT CLAMP COPPER ASSM V-TYPE 2D	
FINISH:		MATERIAL:		DWG NO.	
DATE:		SIGNATURE:		A	
DRAWN: SAURABH				SCALE:	SHEET: 1 OF 1
CHK'D:					
APPY'D:					
MFG:					

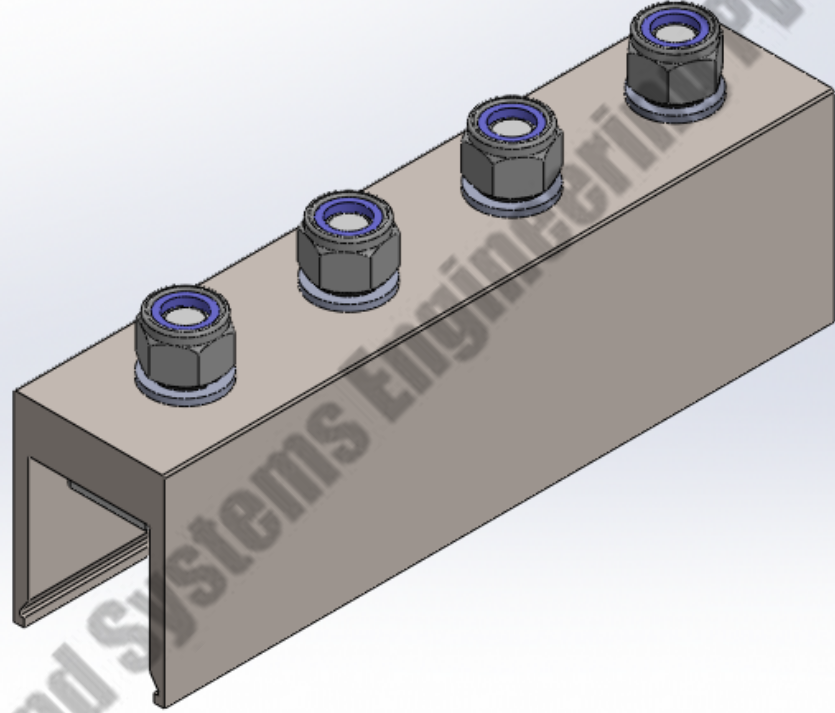

Anand Systems Engineering Pvt. Ltd.

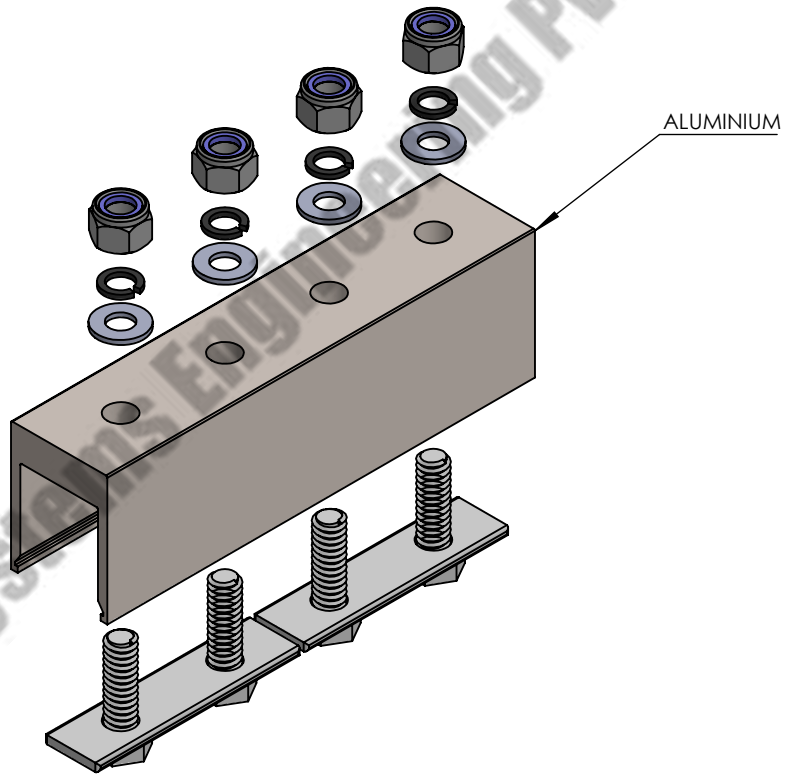
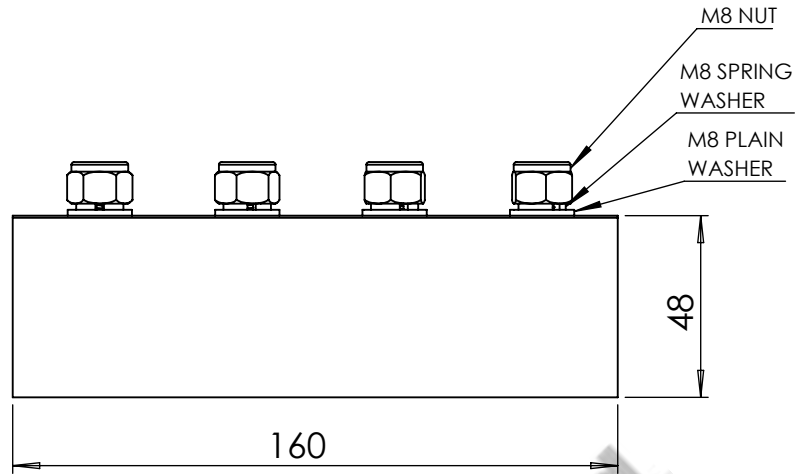
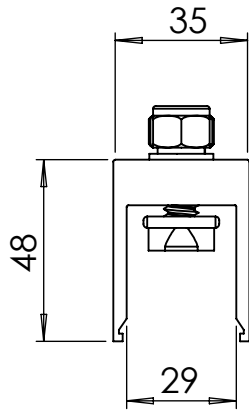

COMPANY NAME:



ANAND SYSTEM
ENGINEERING PVT LTD

DO NOT SCALE DRAWING.

REVISION:

TITLE:

JOINT
CLAMP ALU
ASSM V-TYPE
2D

Email id: info@anandcontrol.in

CONTACT NO: 9137620579

FINISH:

DWG NO.

DATE:

SIGNATURE:

DRAWN	SAURABH
CHK'D	
APP'D	
MFG	

MATERIAL:

WEIGHT:

SCALE:

SHEET: 1 OF 1

A

NUT M8

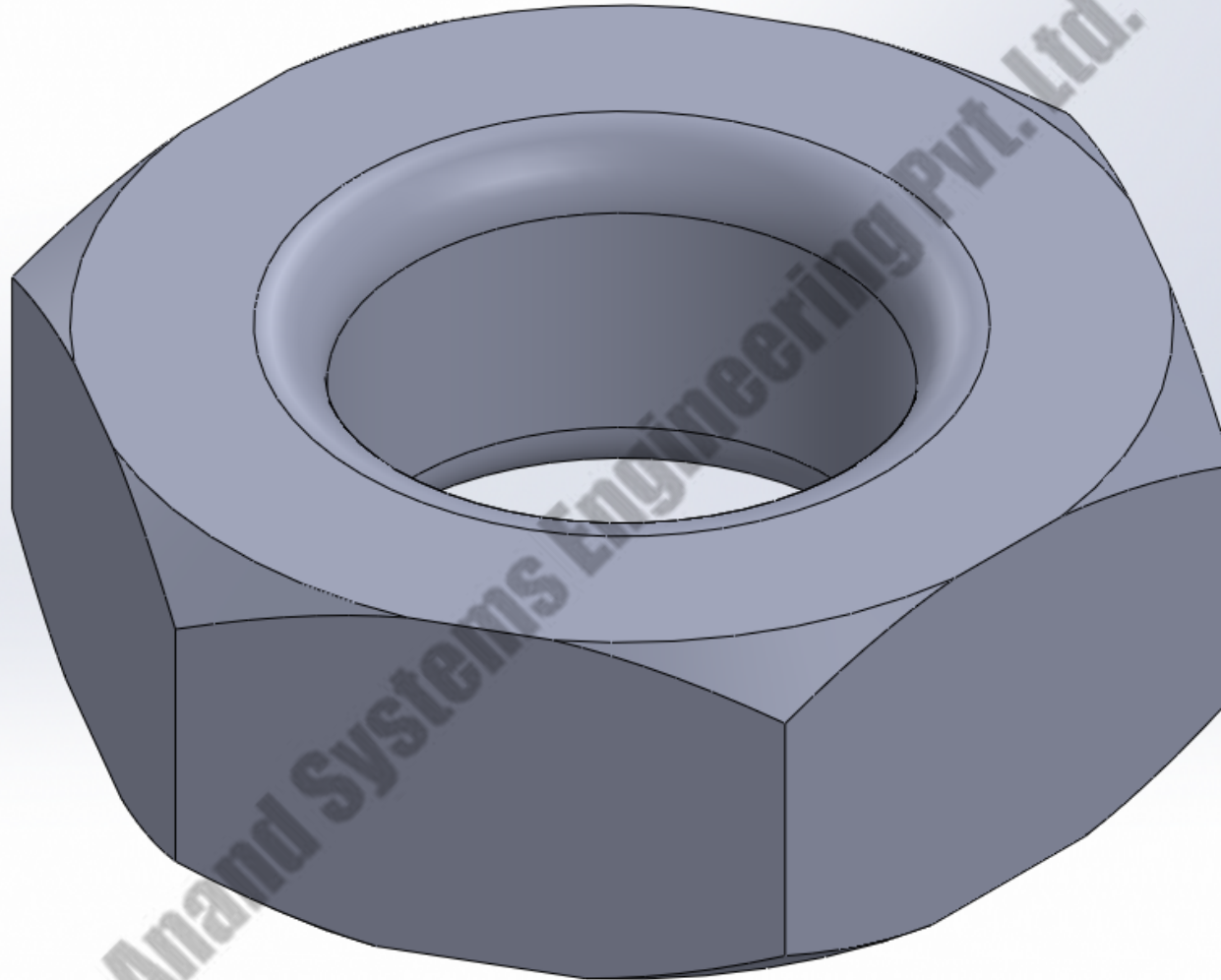

BOLT M10

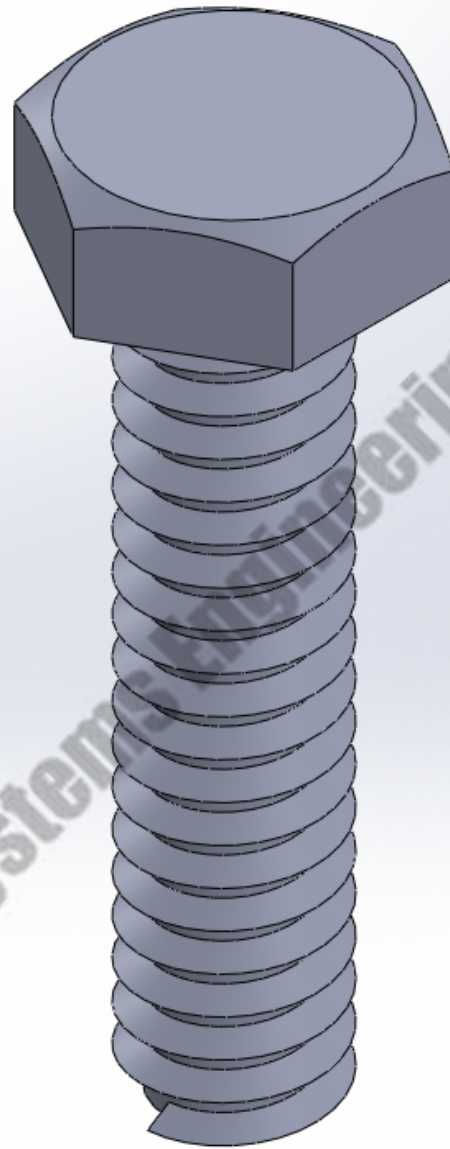

BRASS BUSH END COVER

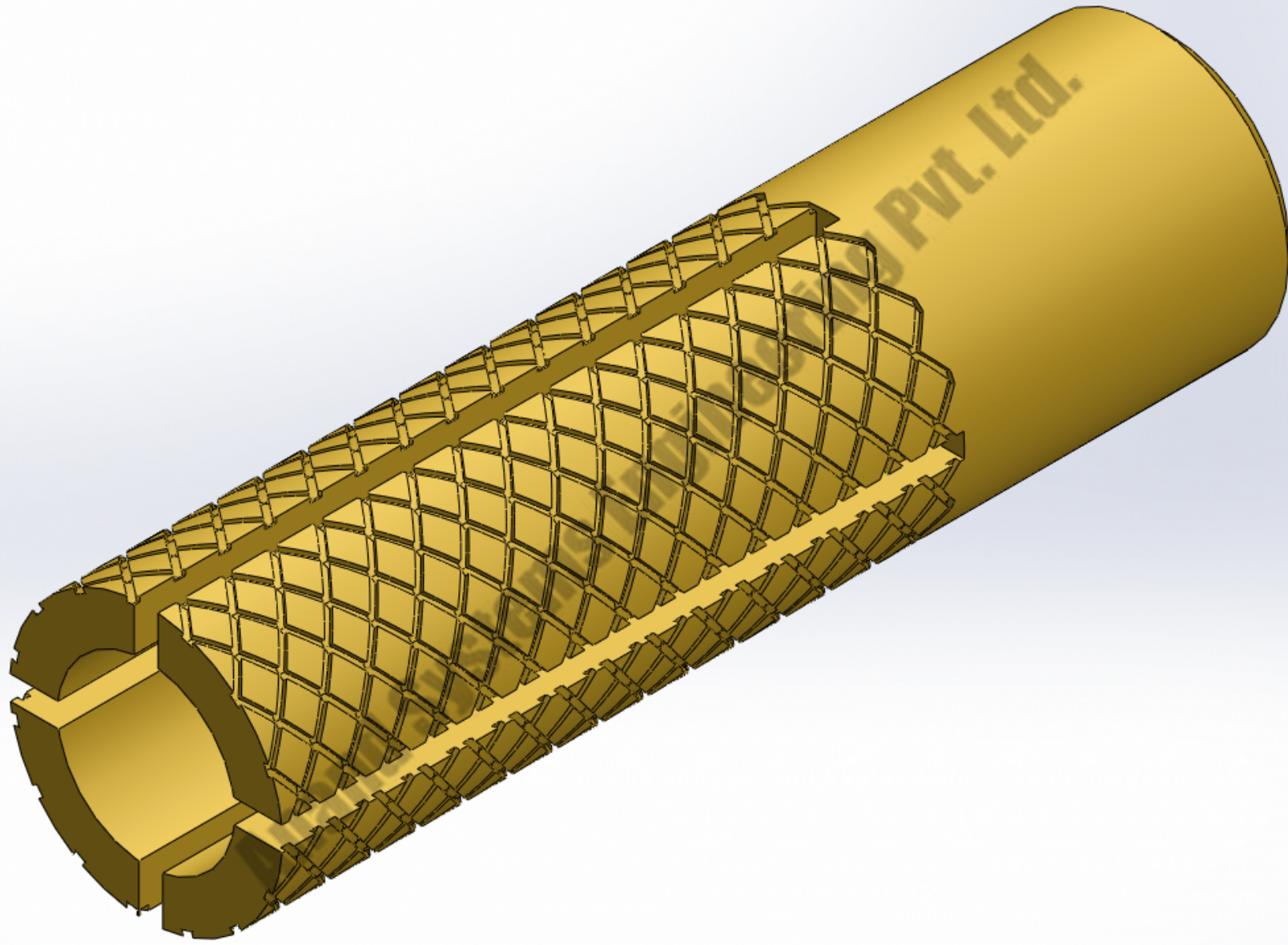

4

3

2

1

F

F

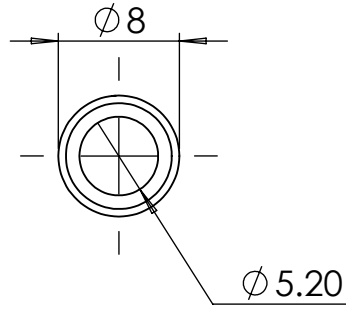

E

E

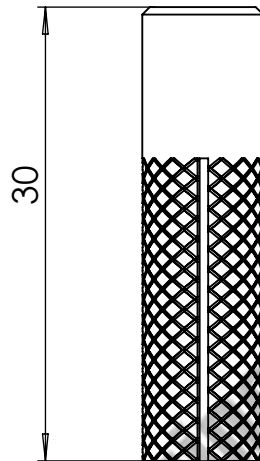

D

D

C

C

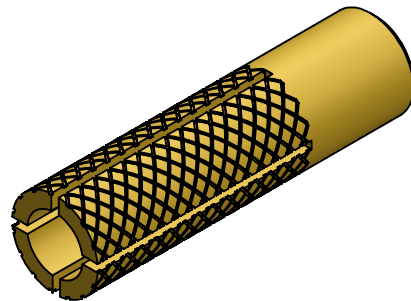

B

B

COMPANY NAME:



ANAND SYSTEM
ENGINEERING PVT LTD

DO NOT SCALE DRAWING.

REVISION:

TITLE:

BRASS BUSH END
COVER V TYPE

Email id: info@anandcontrol.in

CONTACT NO: 9137620579

FINISH:

DWG NO.

DATE:

SIGNATURE:

A

A

DRAWN	SAURABH			MATERIAL:			
CHK'D							A
APP'D							
MFG				WEIGHT:		SCALE:	SHEET: 1 OF 1

4

3

2

1

ALENKEY BOLT M6
END COVER

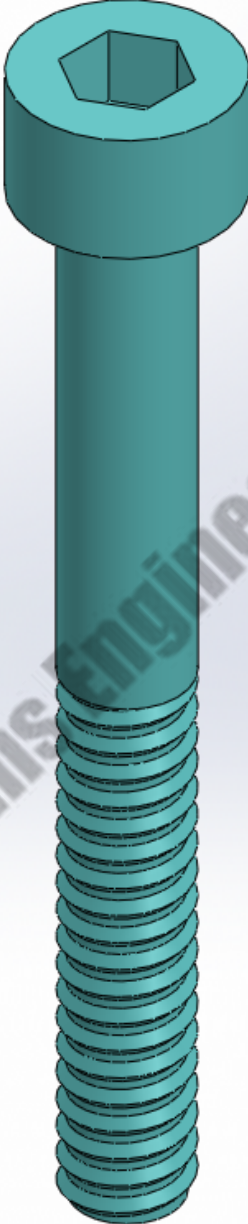

Anand Systems Engineering Pvt. Ltd.

WIRE LUG

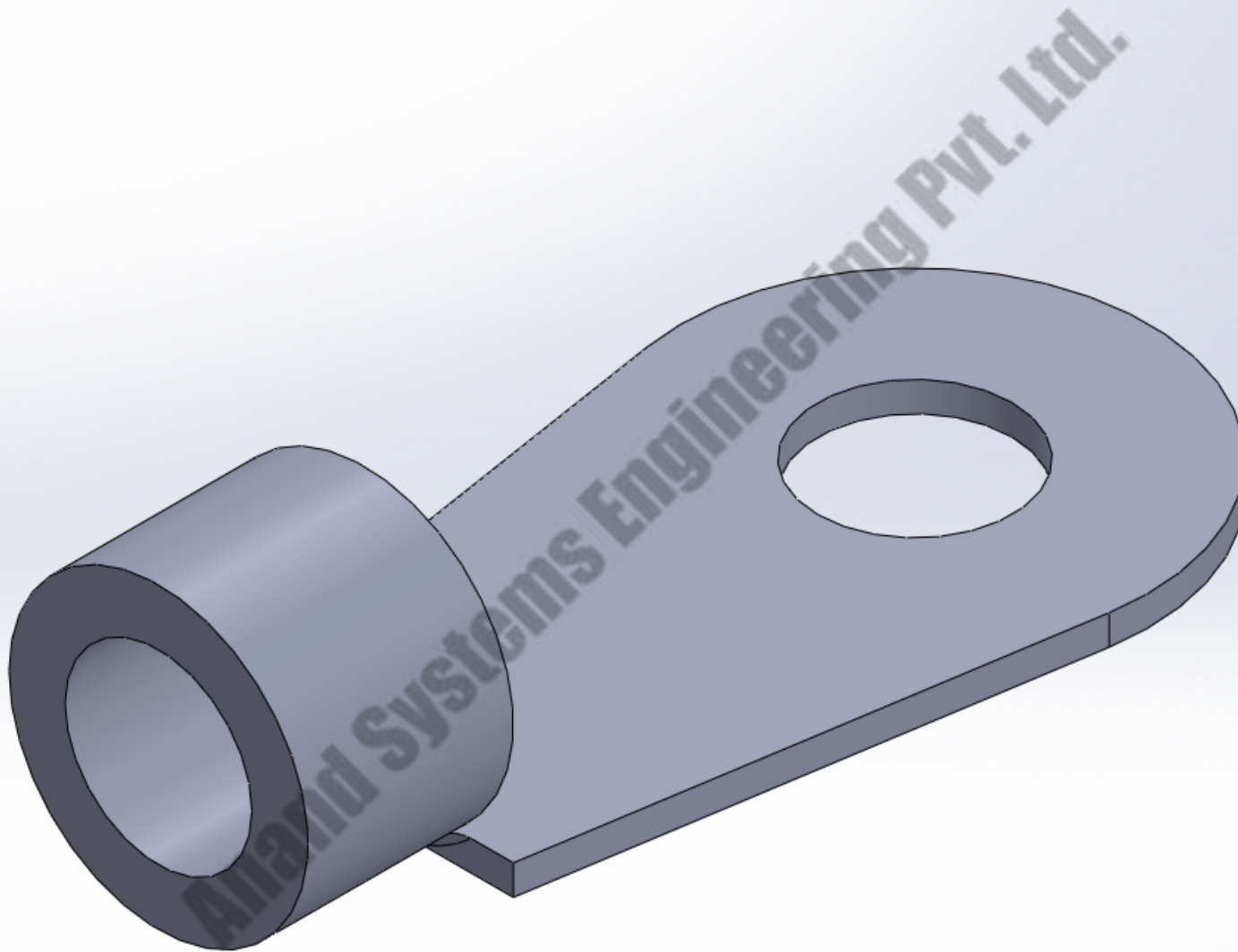

M8 BOLT
SINGLE POLE HANGER
CLAMP

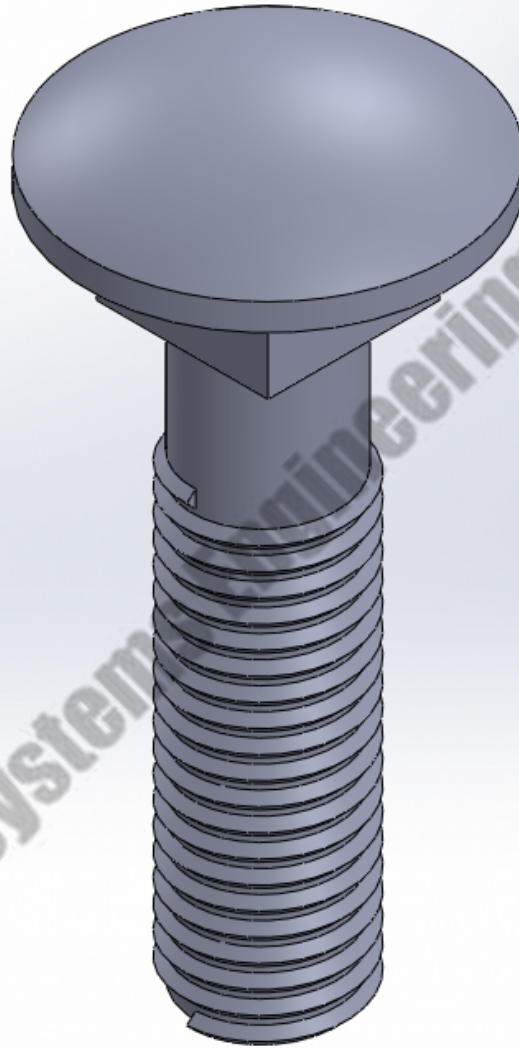

4

3

2

1

F

F

E

E

D

D

C

C

B

B

A

A

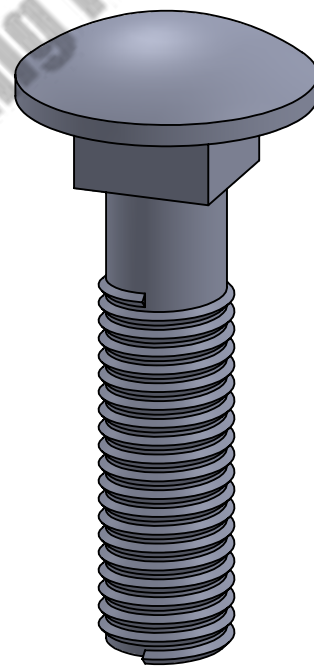
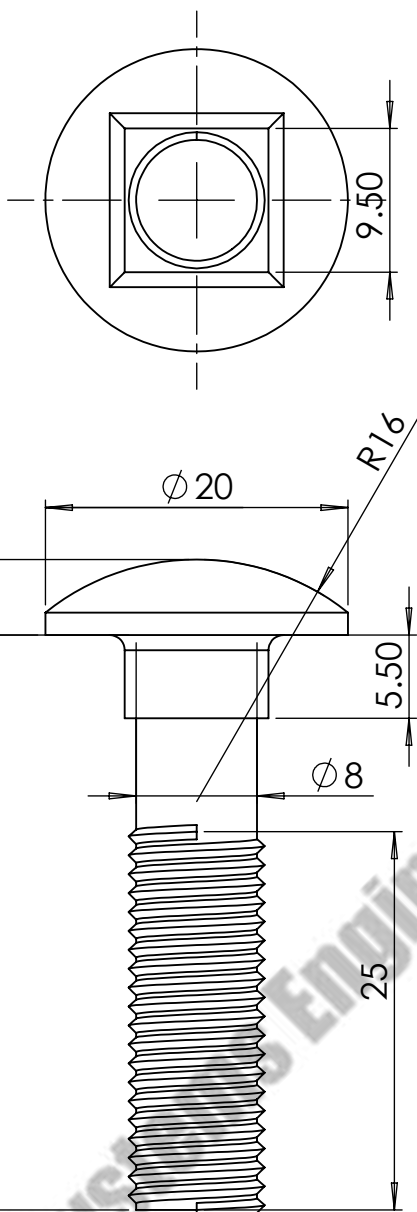

Anand System Engineering Pvt. Ltd.

COMPANY NAME:



ANAND SYSTEM
ENGINEERING PVT LTD

DO NOT SCALE DRAWING.

REVISION:

TITLE:

CLAMP BOLT
M8 2D

Email id: info@anandcontrol.in

CONTACT NO: 9137620579

FINISH:

DWG NO.

DATE:

SIGNATURE:

DRAWN	SAURABH
CHK'D	
APP'D	
MFG	

MATERIAL:

WEIGHT:

SCALE:

SHEET: 1 OF 1

4

3

2

1

BUSH NUT
SINGLE POLE HANGER
CLAMP

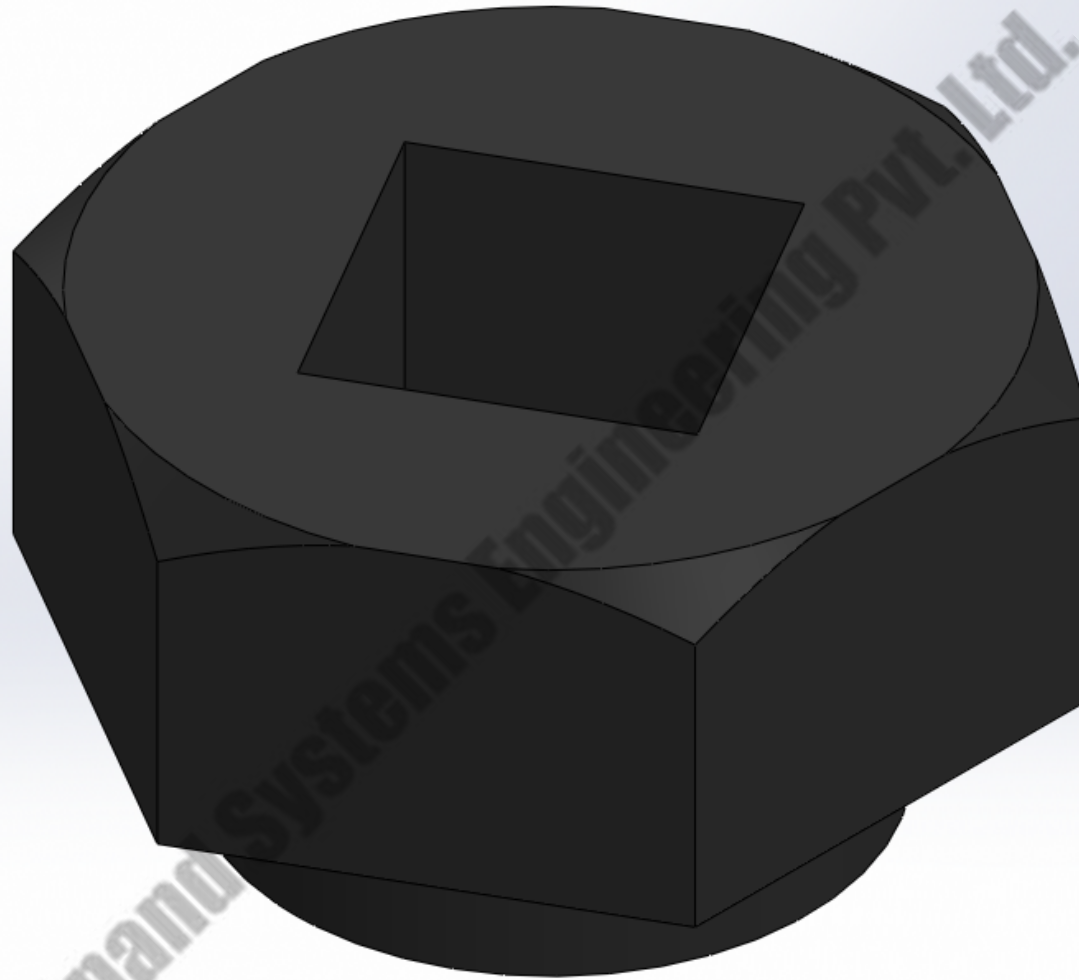

4

3

2

1

F

F

E

E

D

D

C

C

B

B

A

A

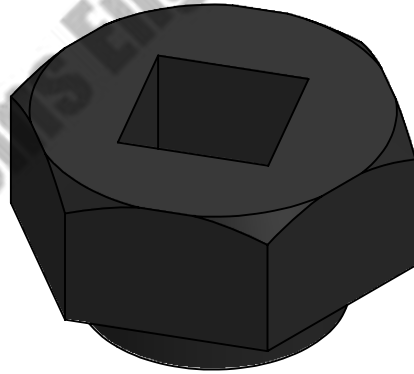
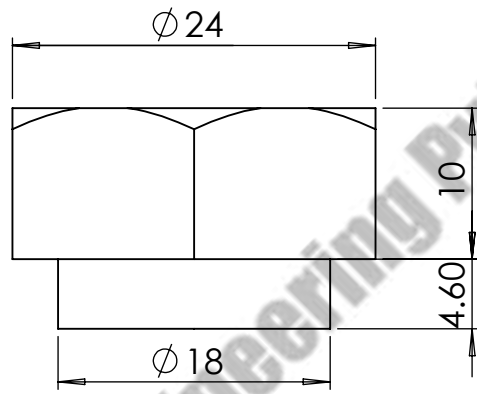
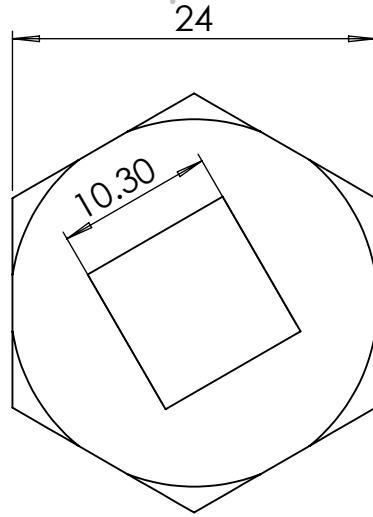

COMPANY NAME:



ANAND SYSTEM
ENGINEERING PVT LTD

DO NOT SCALE DRAWING.

REVISION:

TITLE:

CLAMP BUSH
V TYPE 2D

Email id: info@anandcontrol.in

CONTACT NO: 9137620579

FINISH:

DWG NO.

DATE:

SIGNATURE:

A

DRAWN	SAURABH
CHK'D	
APP'D	
MFG	

MATERIAL:

WEIGHT:

SCALE:

SHEET: 1 OF 1

4

3

2

1

COPPER JUMPER
EXPANSION JOINT

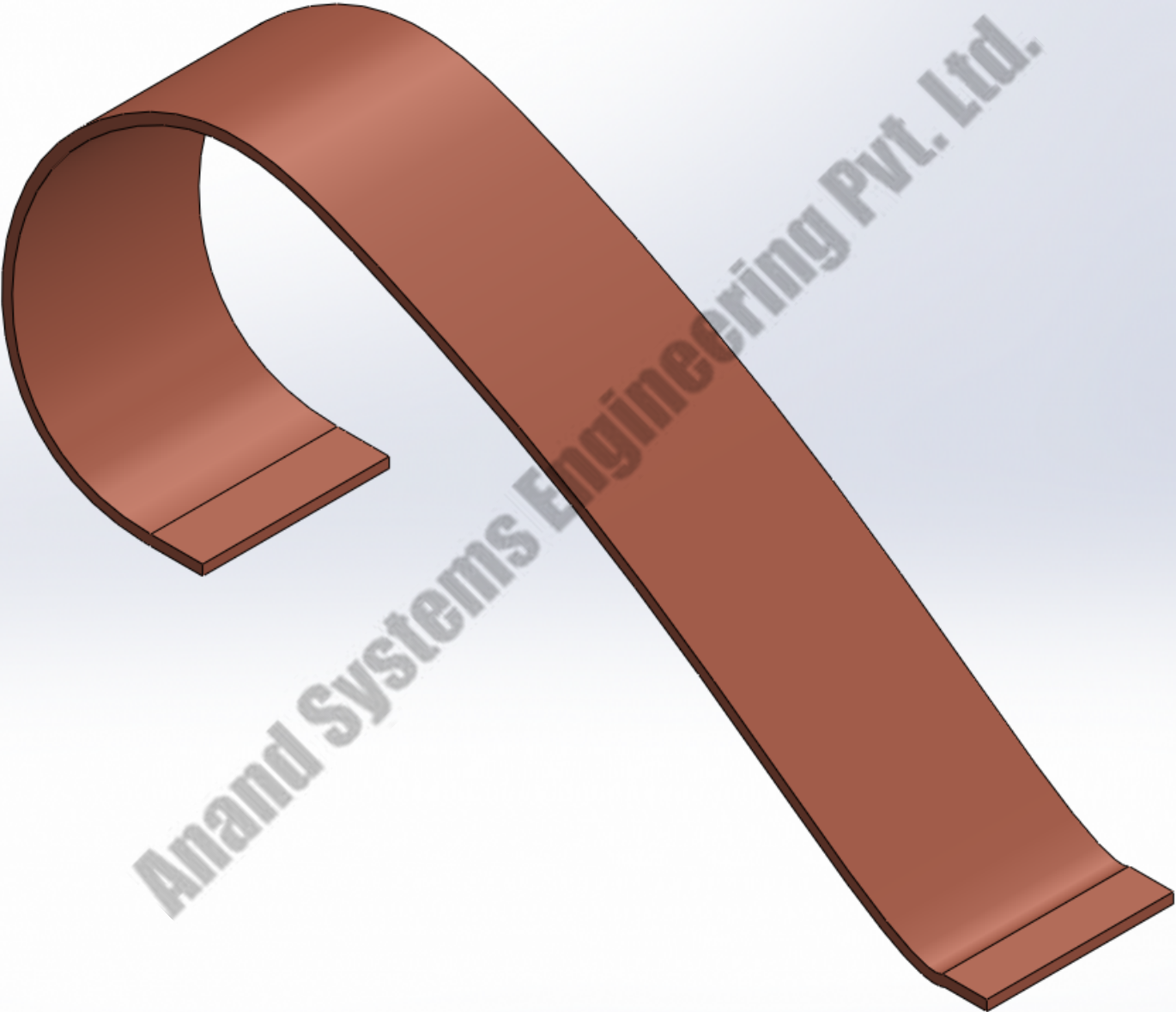

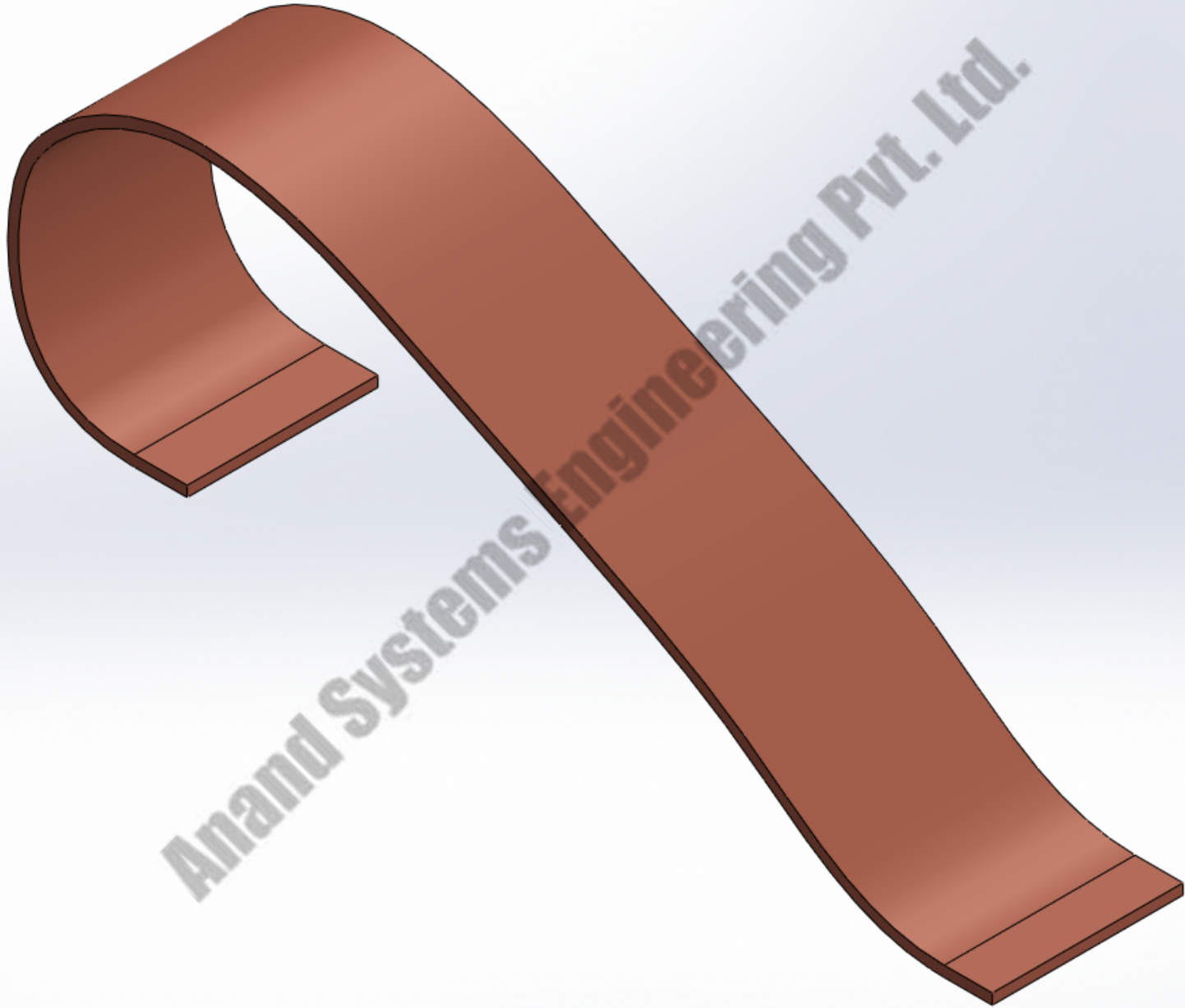

Anand Systems Engineering Pvt. Ltd.

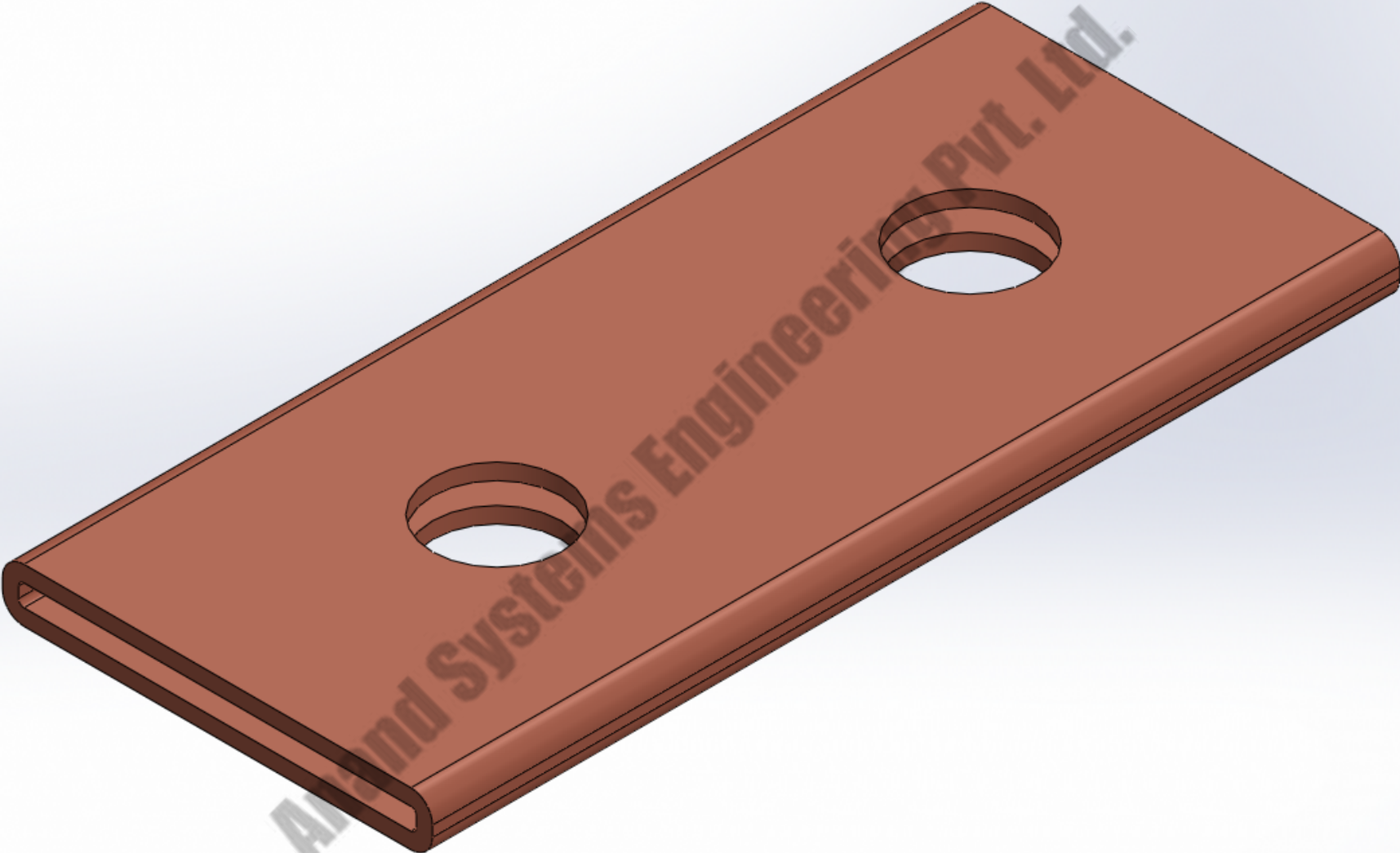

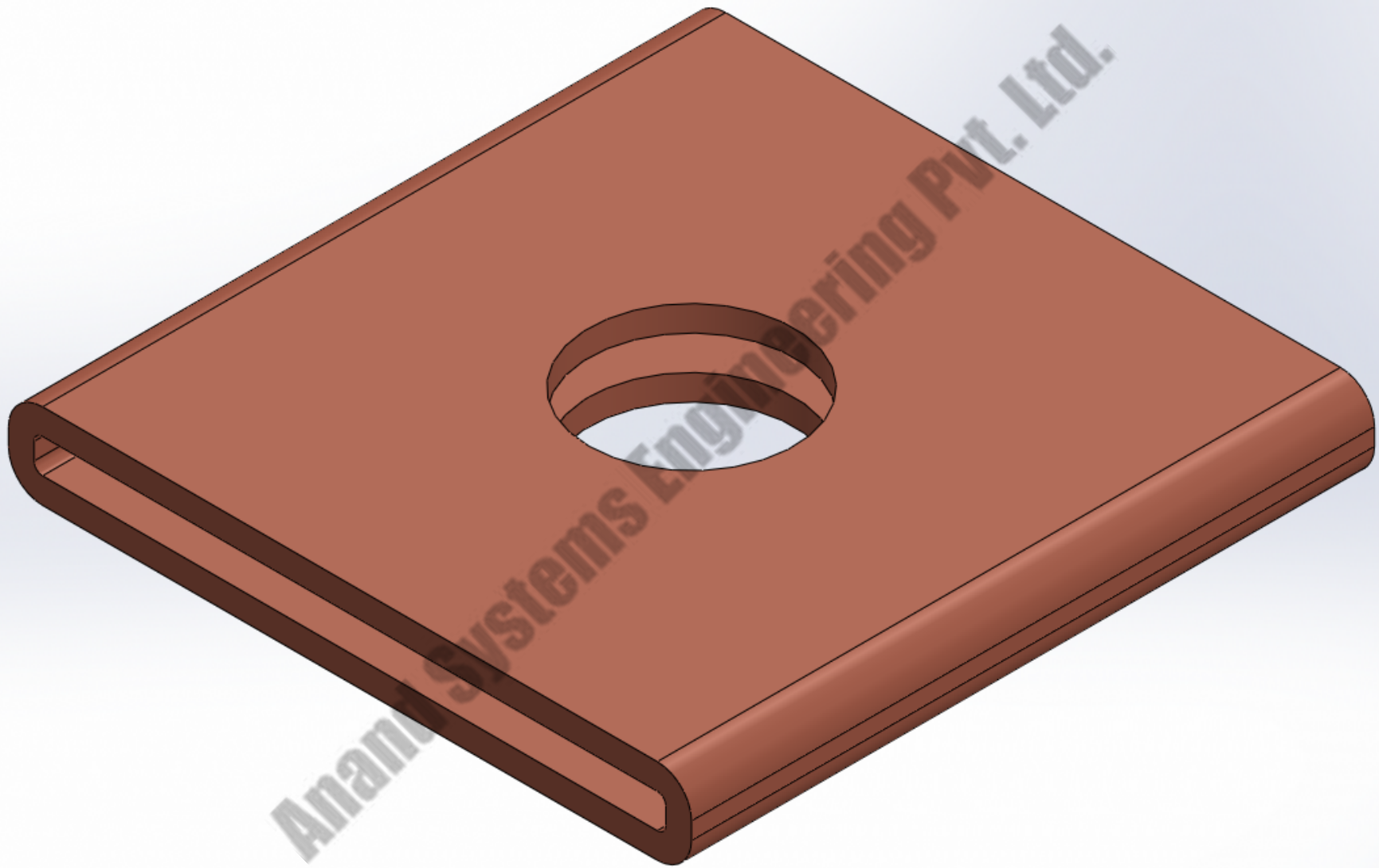

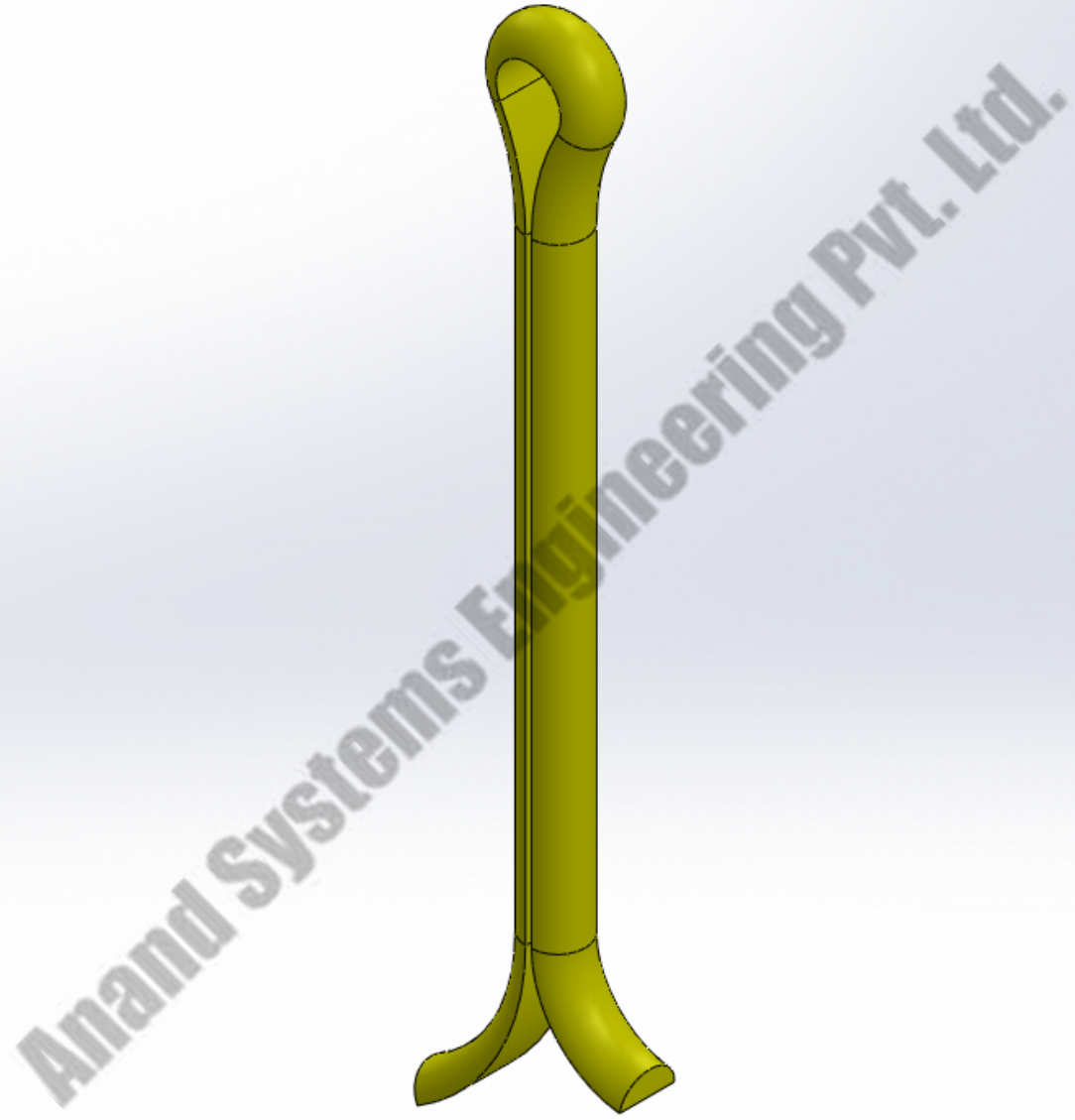

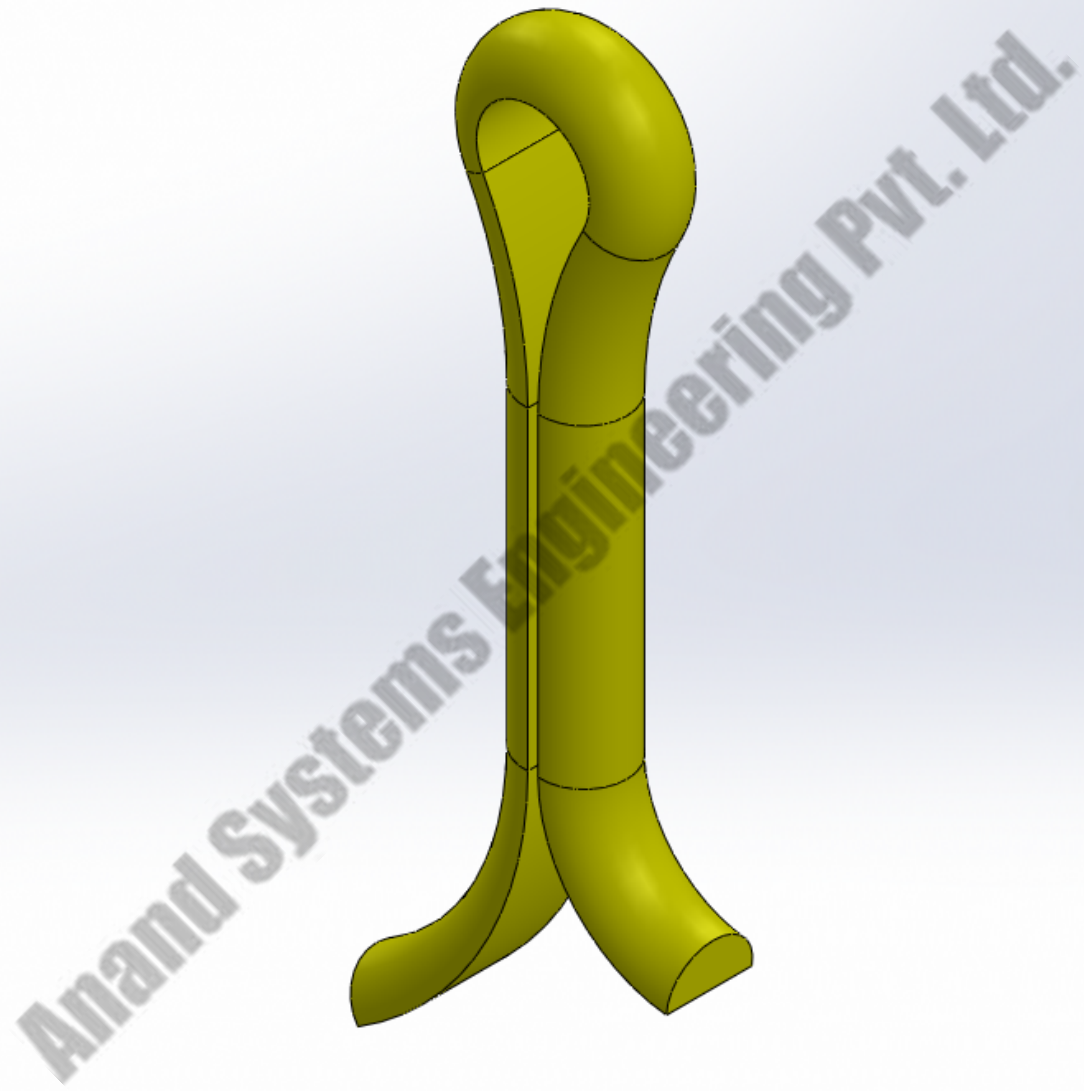

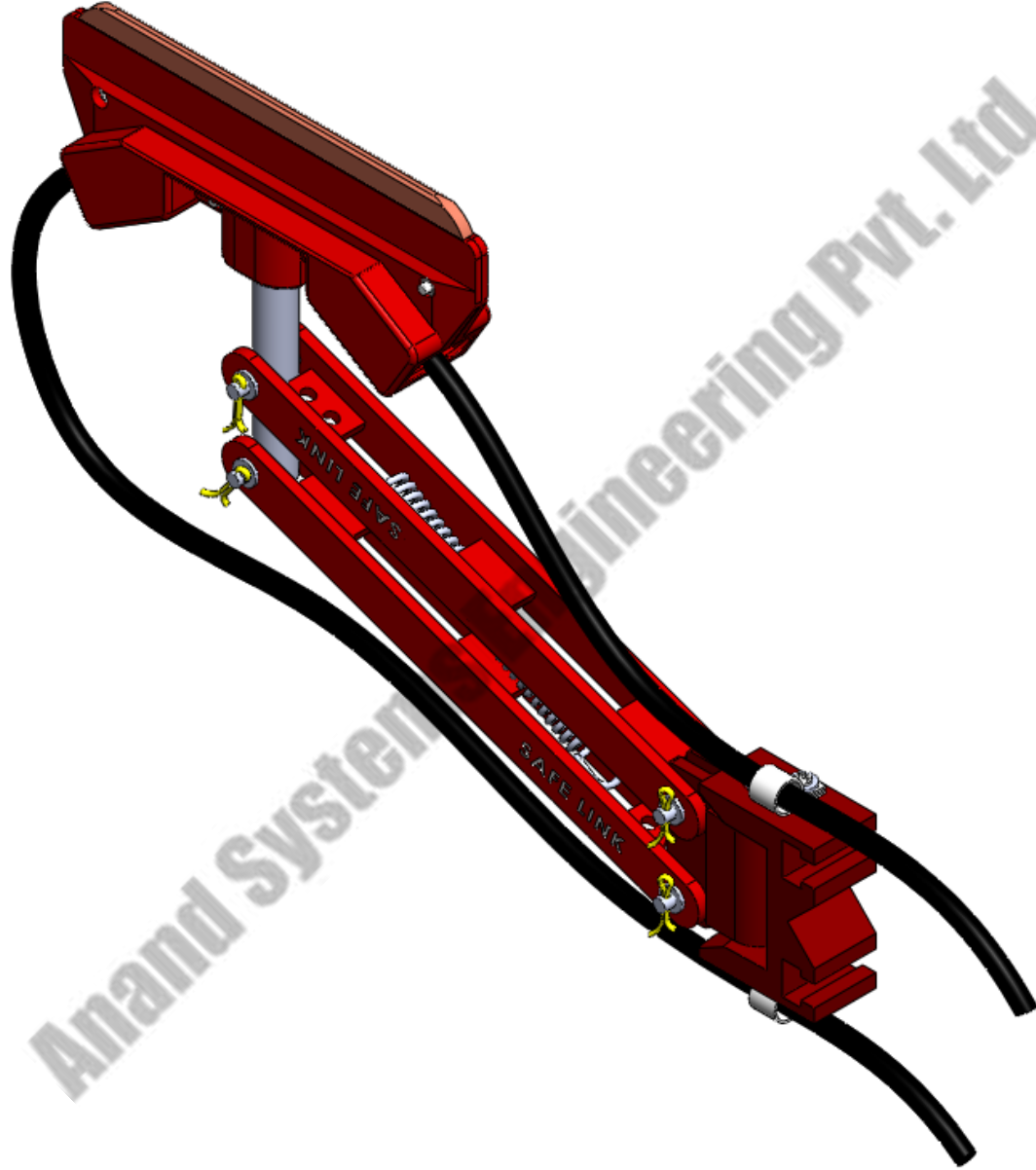

EXPLODED VIEW

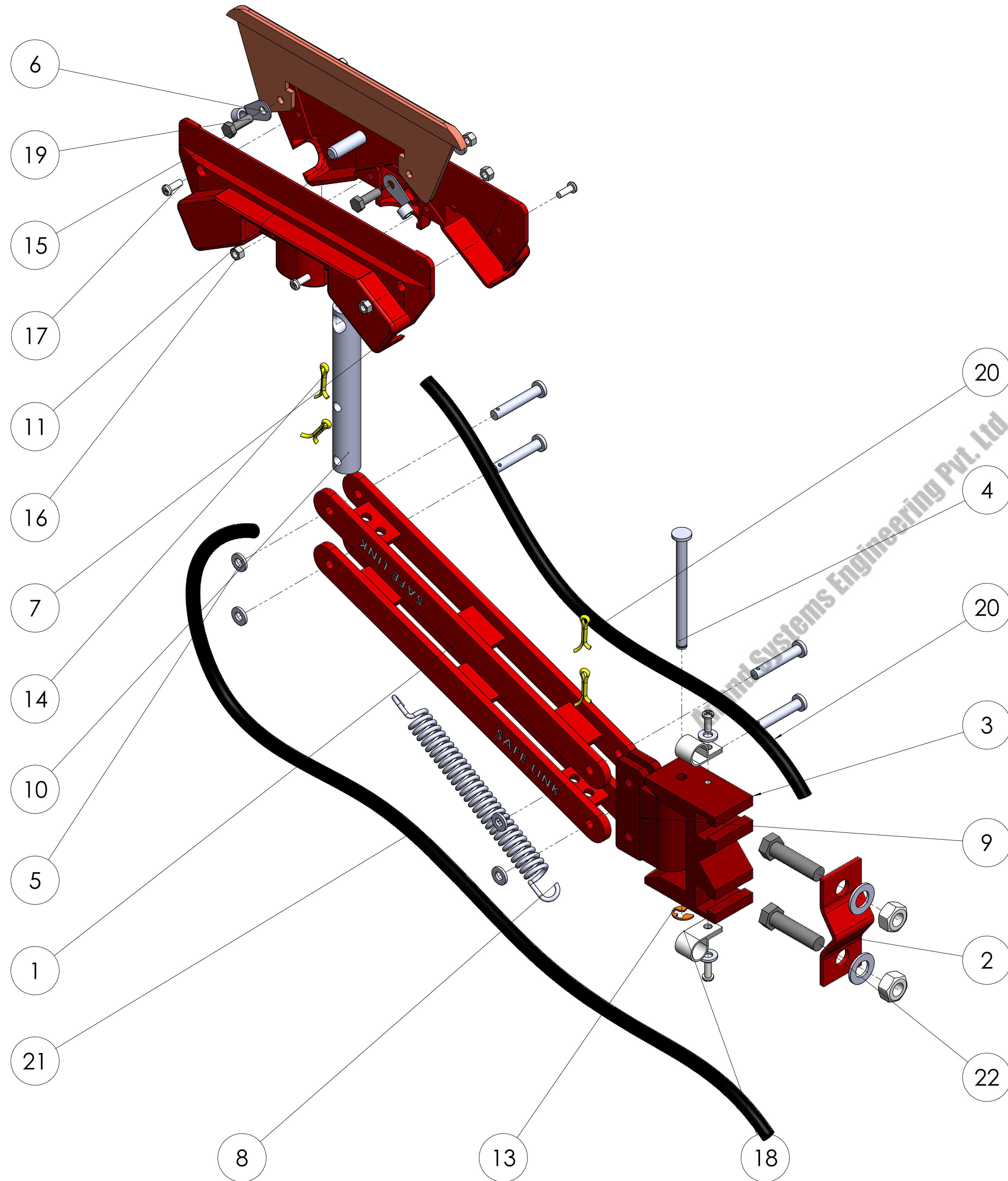

ITEM NO.	PART NAME	DESCRIPTION	MATERIAL	QTY.
1	ARM	245X19X3	ALUMINIUM	2
2	LOWER BRACKET 1	73X30X3	M.S.	1
3	LOWER BRACKET 2	73X56X30	M.S.	1
4	PIN 16X70	16X70	M.S.	1
5	PLAIN WASHER	11X5.5X1.5	M.S.	8
6	SHOE	186.5X56X3	CARBON	1
7	SHOE HOLDER	200X64X19	PLASTIC	2
8	SPRING	TENSION SPRING	SPRING STEEL	1
9	VERTICAL LEVER	61X50X24	M.S.	1
10	VERTICAL STUD	16X110	M.S.	1
11	VERTICAL STUD PIN	8X22	M.S.	1
12	SPACER PIN	40X6	ALUMINIUM	4
13	E CIRCLIP	7X25	SPRING STEEL	1
14	COTTER PIN	1/8"X 3/4"	M.S.	4
15	HEX BOLT	5X20	M.S.	2
16	HEX NUT	G.I. HEXNUT M5	M.S.	6
17	STAR SCREW	M4X6.5	M.S.	6
18	WIRE TIE CLIP	CABLE CLAMP	PLASTIC	2
19	CABLE LUG	6MM	COPPER	2
20	CABLE 1	25 SQ mm		1
21	CABLE 2	25 SQ mm		1
22	HEX BOLT	M8, 8X20, END COVER FIXING	M.S.	2
23	HEX NUT	3/8"	M.S.	2
24	PLAIN WASHER	19X10.5X1.5	M.S.	2

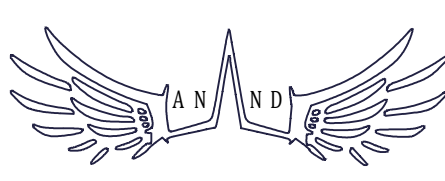
COMPANY NAME:  ANAND SYSTEMS ENGINEERING PVT LTD

EMAIL ID: info@anandcontrol.in

CONTACT NO: 9137620579

TITLE: CURRENT COLLECTOR 250 AMP 2D

SCALE: 1:1

SHEET: 1 OF 1

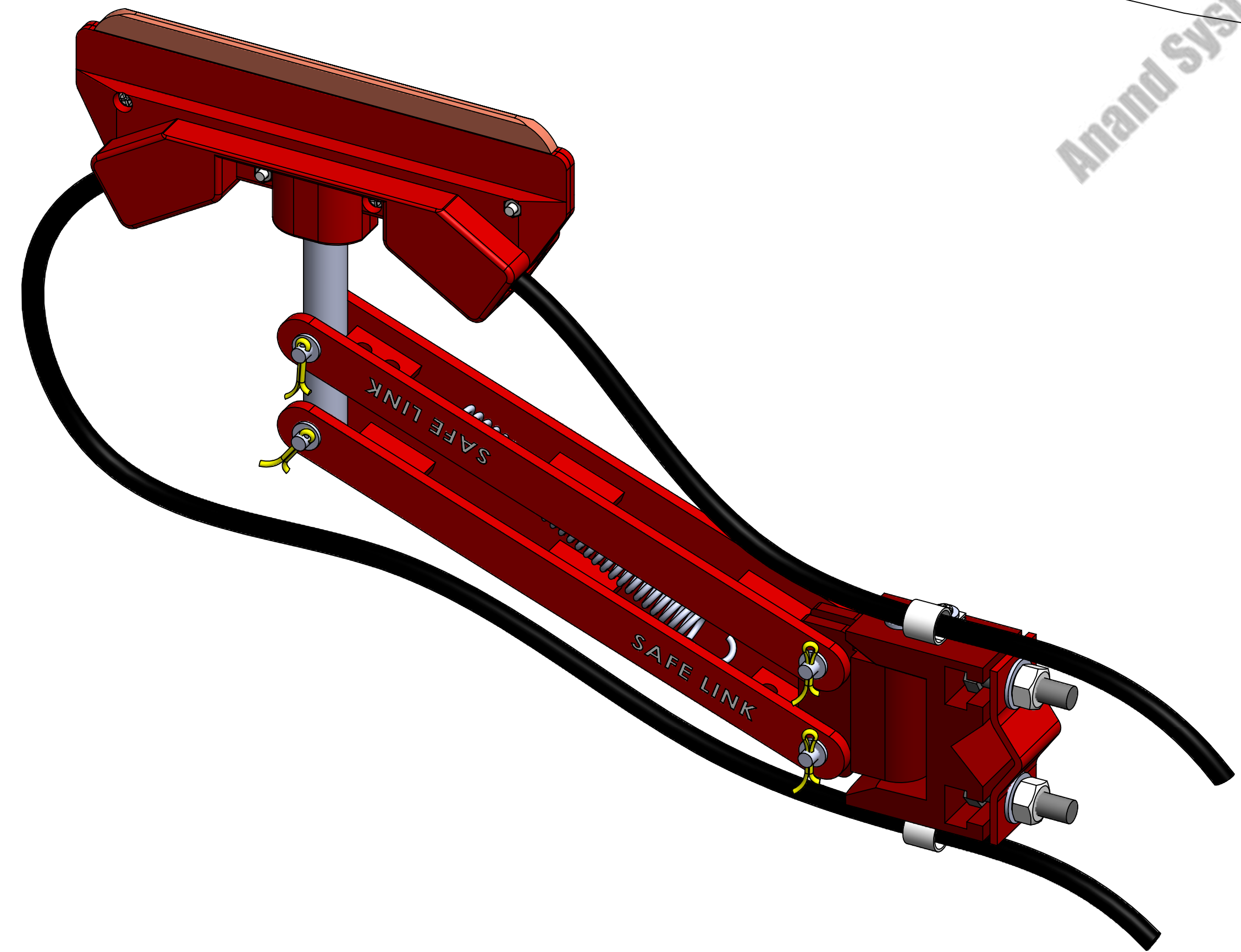
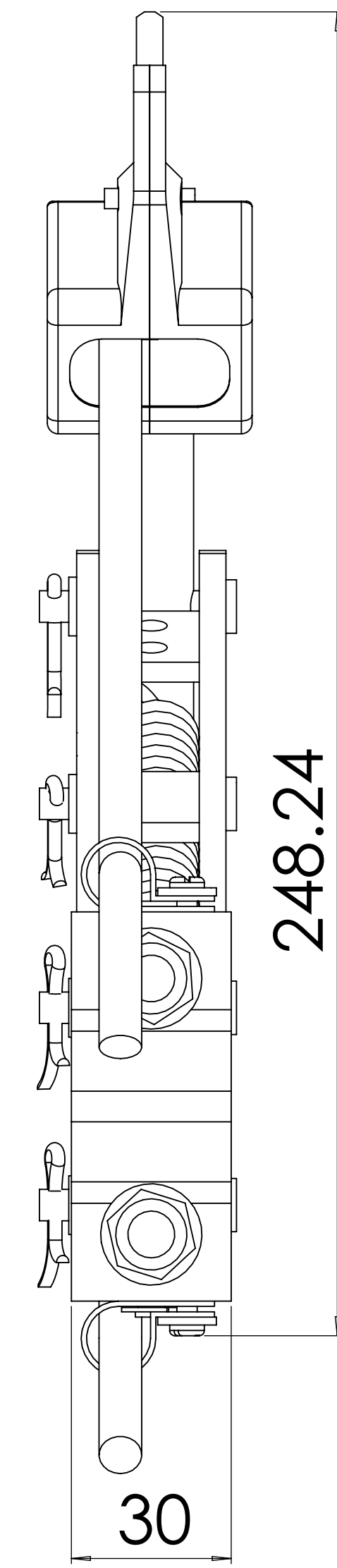
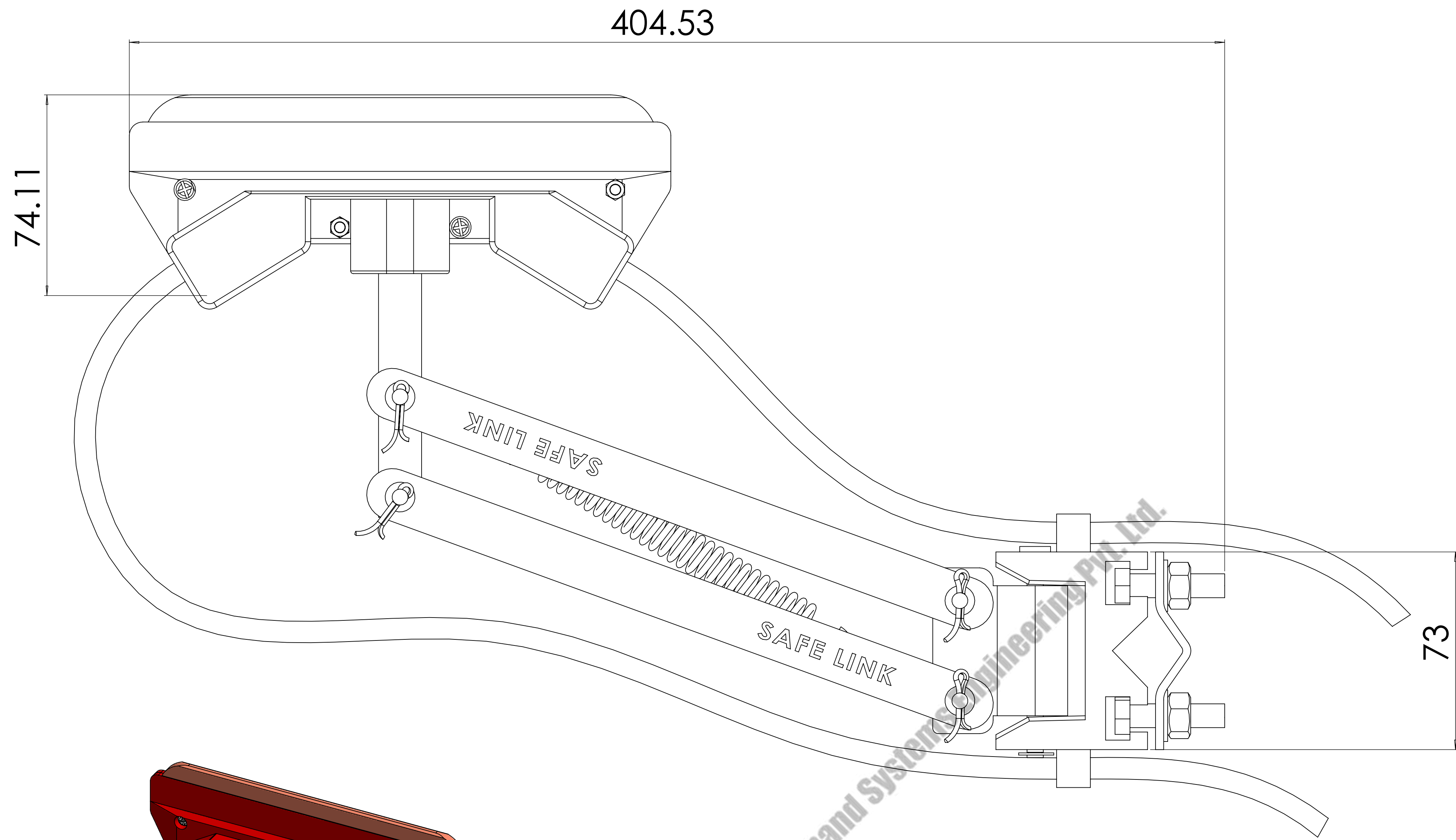

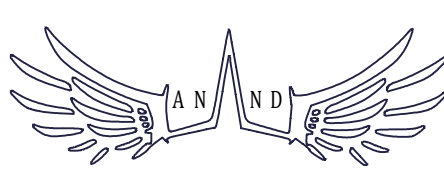
COMPANY NAME:		ANAND SYSTEM ENGINEERING PVT LTD		DO NOT SCALE DRAWING		REVISION:	
		Email id: info@anandcontrol.in CONTACT NO: 9137620579		TITLE: CURRENT COLLECTOR 250 AMP 2D		DWG. NO.: DATE:	
DRAWN: CHKD: APPD: MFC	SAURABH	FINISH:	MATERIAL:	SCALE:	SIGNATURE:	SHEET: 1 OF 1	A

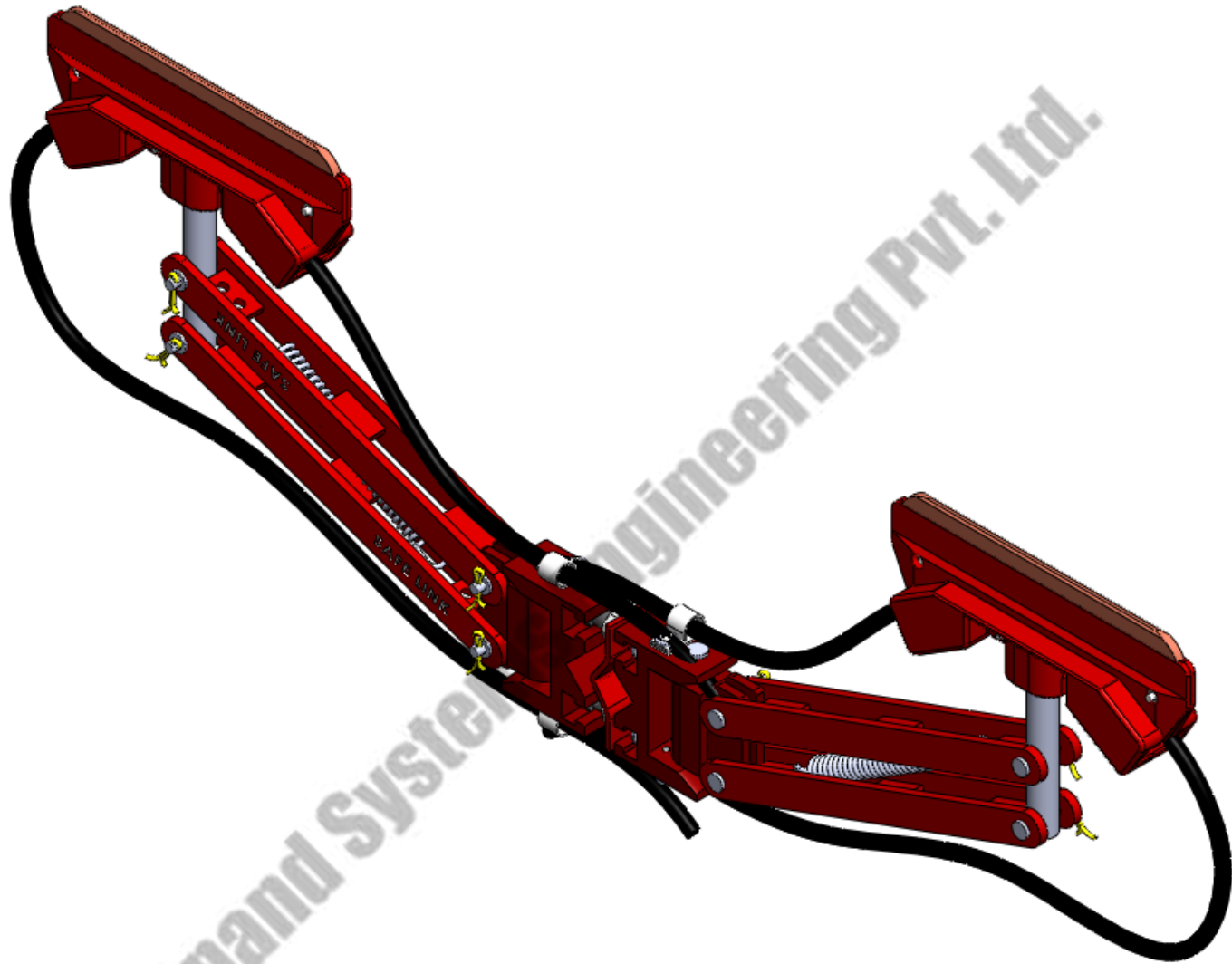

Anand Systems Engineering Pvt. Ltd.

EXPLODED VIEW

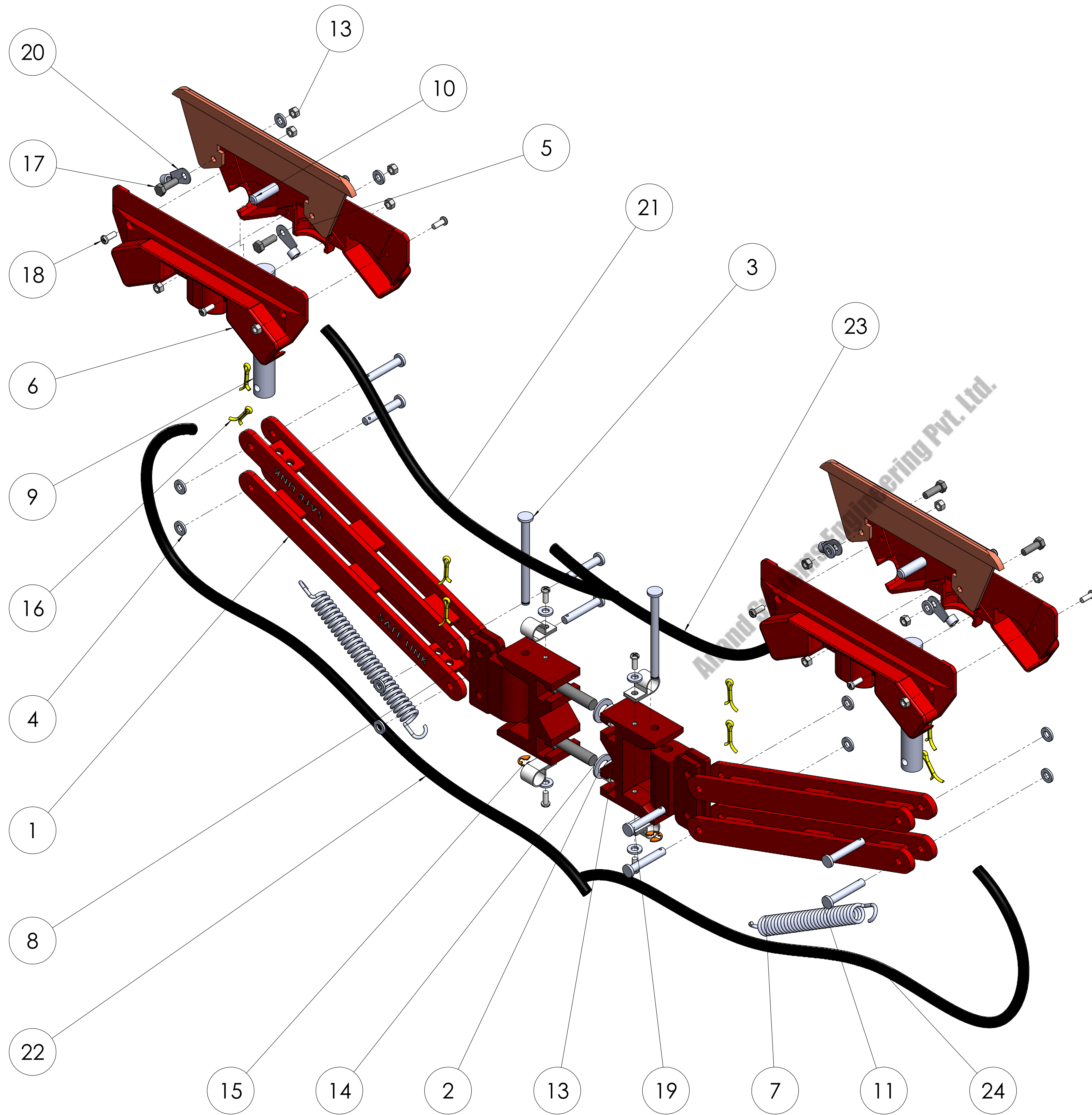

ITEM NO.	PART NAME	DESCRIPTION	Material	QTY.
1	ARM	220X16X3	ALUMINIUM	4
2	LOWER BRACKET 2	73X56X30	M.S.	2
3	LOWER PIN	M8X75	M.S.	2
4	PLAIN WASHER	11X5.5X1.5	M.S.	16
5	SHOE	186.5X56X3	CARBON	2
6	SHOE HOLDER	200X64X19	PLASTIC	4
7	SPRING	TENSION SPRING	SPRING STEEL 4454 GRADE-2	2
8	VERTICAL LEVER	61X50X24	M.S.	2
9	VERTICAL STUD	16X110	M.S.	2
10	VERTICAL STUD PIN	8X22	M.S.	2
11	SPACER PIN	40X6	ALUMINIUM	8
12	HEX BOLT	M8, 8X20, END COVER FIXING	M.S.	2
13	HEX NUT	3/8"	M.S.	14
14	PLAIN WASHER	19X10.5X1.5	M.S.	2
15	E CIRCLIP	M7X25	SPRING STEEL 4454 GRADE-2	2
16	COTTER PIN	1/8"X 3/4"	M.S.	8
17	HEX BOLT	M5X20	M.S.	4
18	STAR SCREW	M4X6.5	M.S.	12
19	WIRE TIE CLIP	CABLE CLAMP	PLASTIC	4
20	CABLE LUG	25 SQ MM	COPPER	4
21	CABLE 1	25 SQ mm	COPPER	1
22	CABLE 2	25 SQ mm	COPPER	1
23	CABLE 3	25 SQ mm	COPPER	1
24	CABLE 4	25 SQ mm	COPPER	1

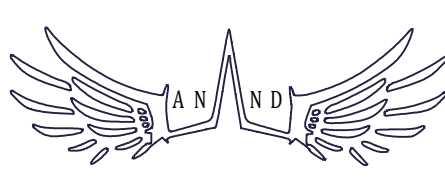
COMPANY NAME:  ANAND SYSTEM ENGINEERING PVT LTD		DO NOT SCALE DRAWING REVISION:
Email id: info@anandcontrol.in CONTACT NO: 9137620579		TITLE: CURRENT COLLECTOR 500AMP 2D
DRAWN: SAURABH CHECKED: APPROVED: DATE:	FINISH: WEIGHT:	DWG. NO.: DATE: SIGNATURE:
SCALE:		SHEET: 1 OF 1

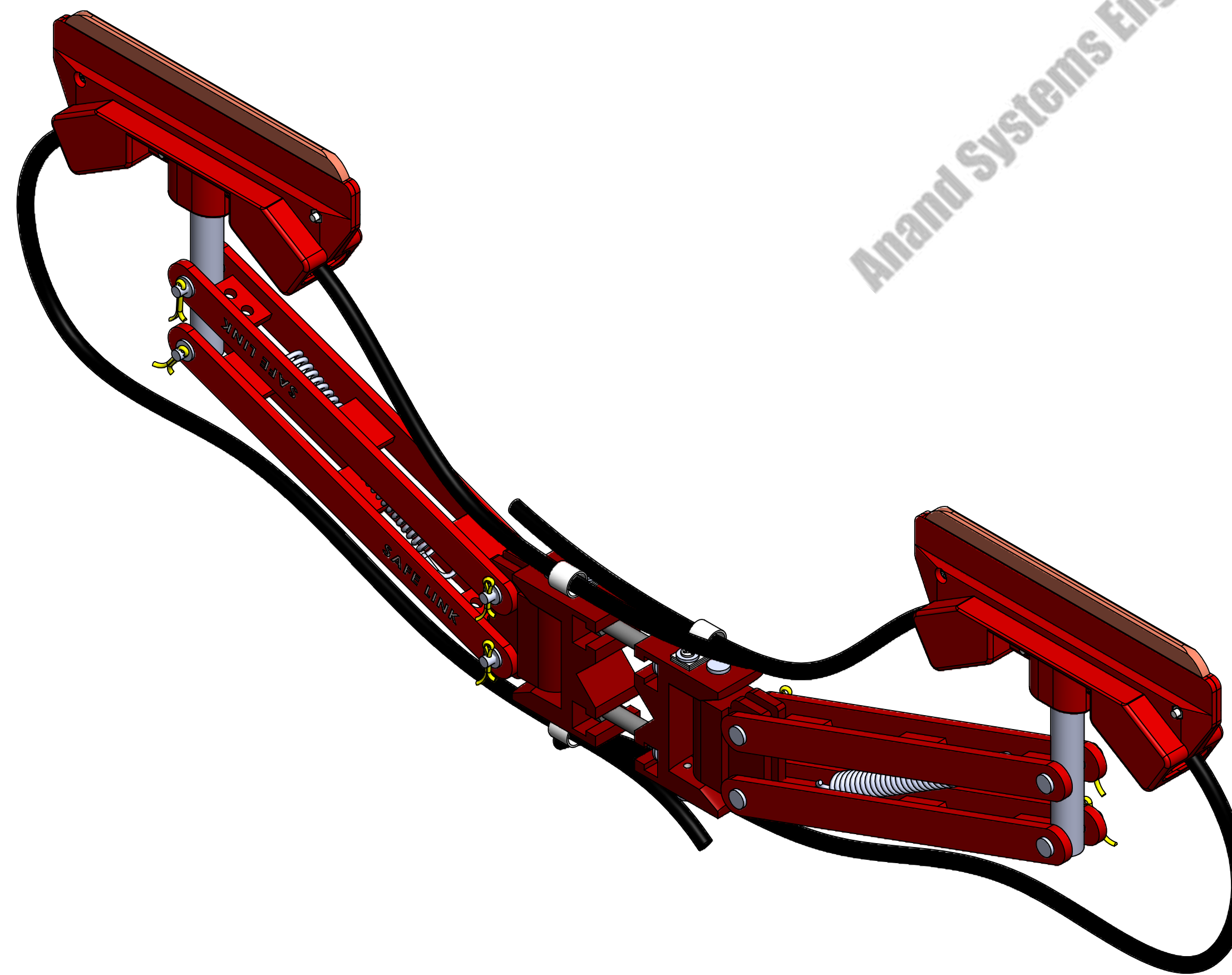
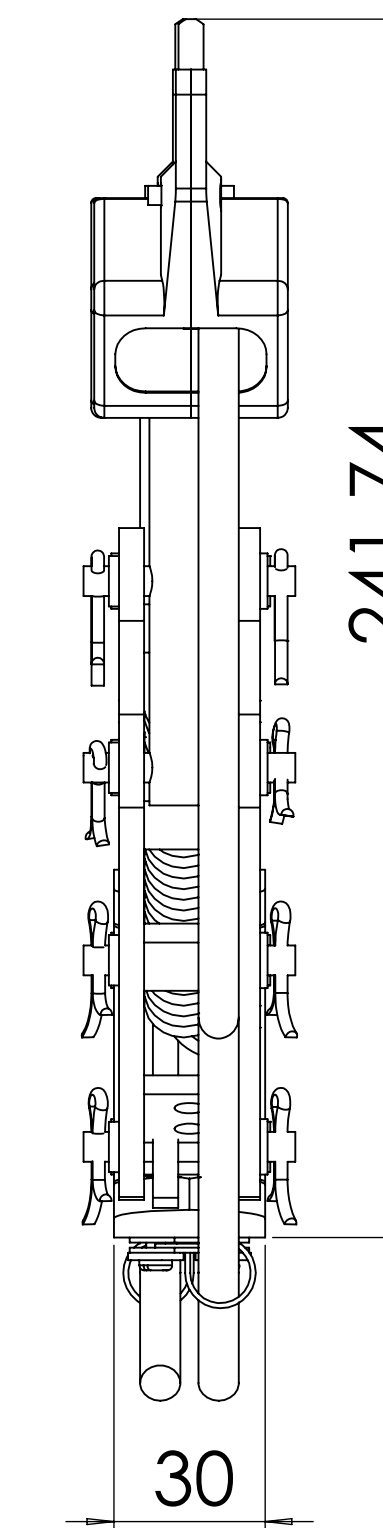
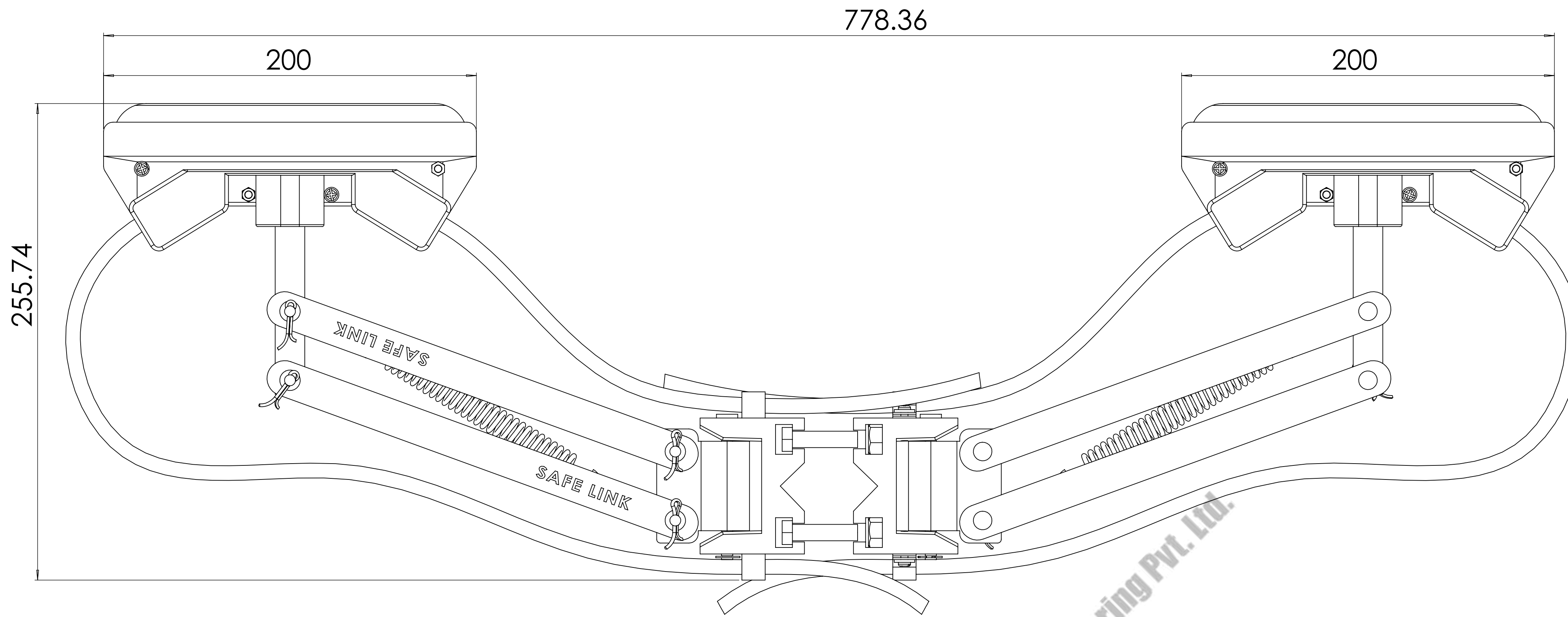

Anand Systems Engineering Pvt. Ltd.

COMPANY NAME:		ANAND SYSTEM ENGINEERING PVT LTD		DO NOT SCALE DRAWING	REVISION:
Email id: info@anandcontrol.in		CONTACT NO: 9137620579		TITLE: CURRENT COLLECTOR 500AMP 2D	
DRAWN:	SAURABH	DATE:	SIGNATURE:	A	
CHECKED:		SCALE:		SHEET: 1 OF 1	
APPROVED:		WEIGHT:			
MFC:					

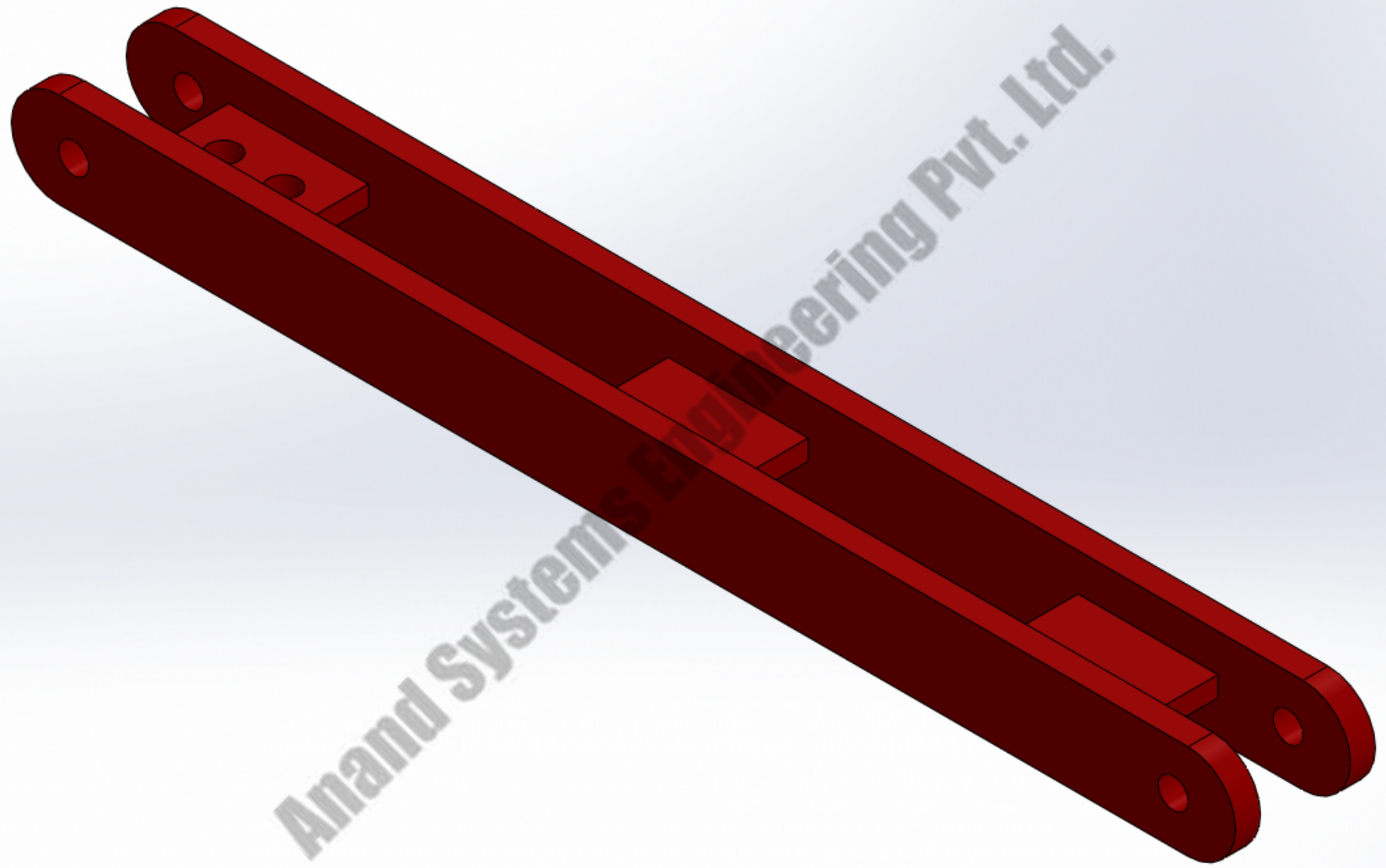

Anand Systems Engineering Pvt. Ltd.

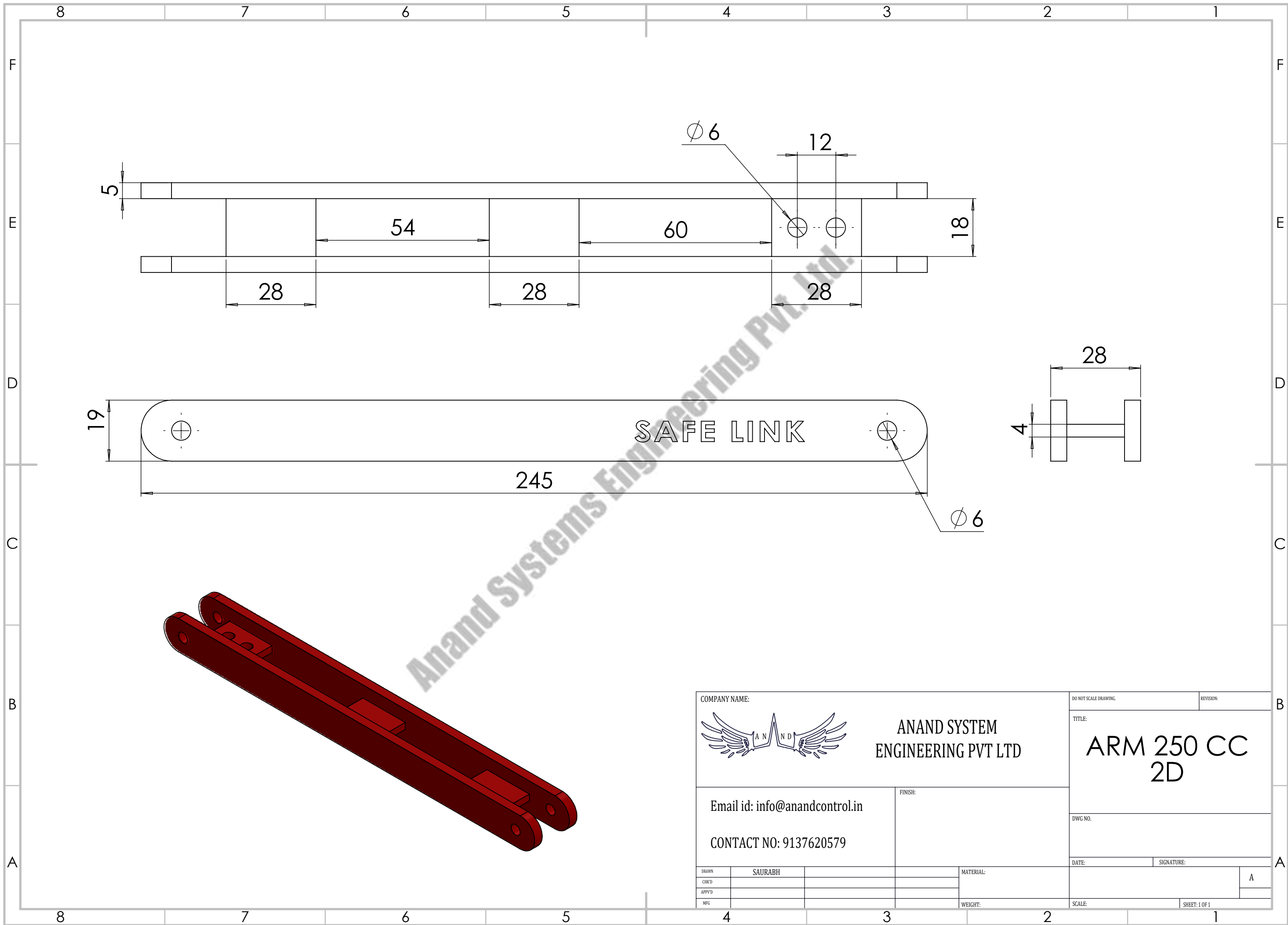

Anand Systems Engineering Pvt. Ltd.

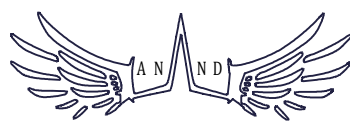
COMPANY NAME:		ANAND SYSTEM ENGINEERING PVT LTD		DO NOT SCALE DRAWING.	REVISION:
		Email id: info@anandcontrol.in CONTACT NO: 9137620579		TITLE: ARM 250 CC 2D	
FINISH:		MATERIAL:		DWG NO.	
DATE:		SIGNATURE:		A	
DRAWN: SAURABH				SCALE:	SHEET: 1 OF 1

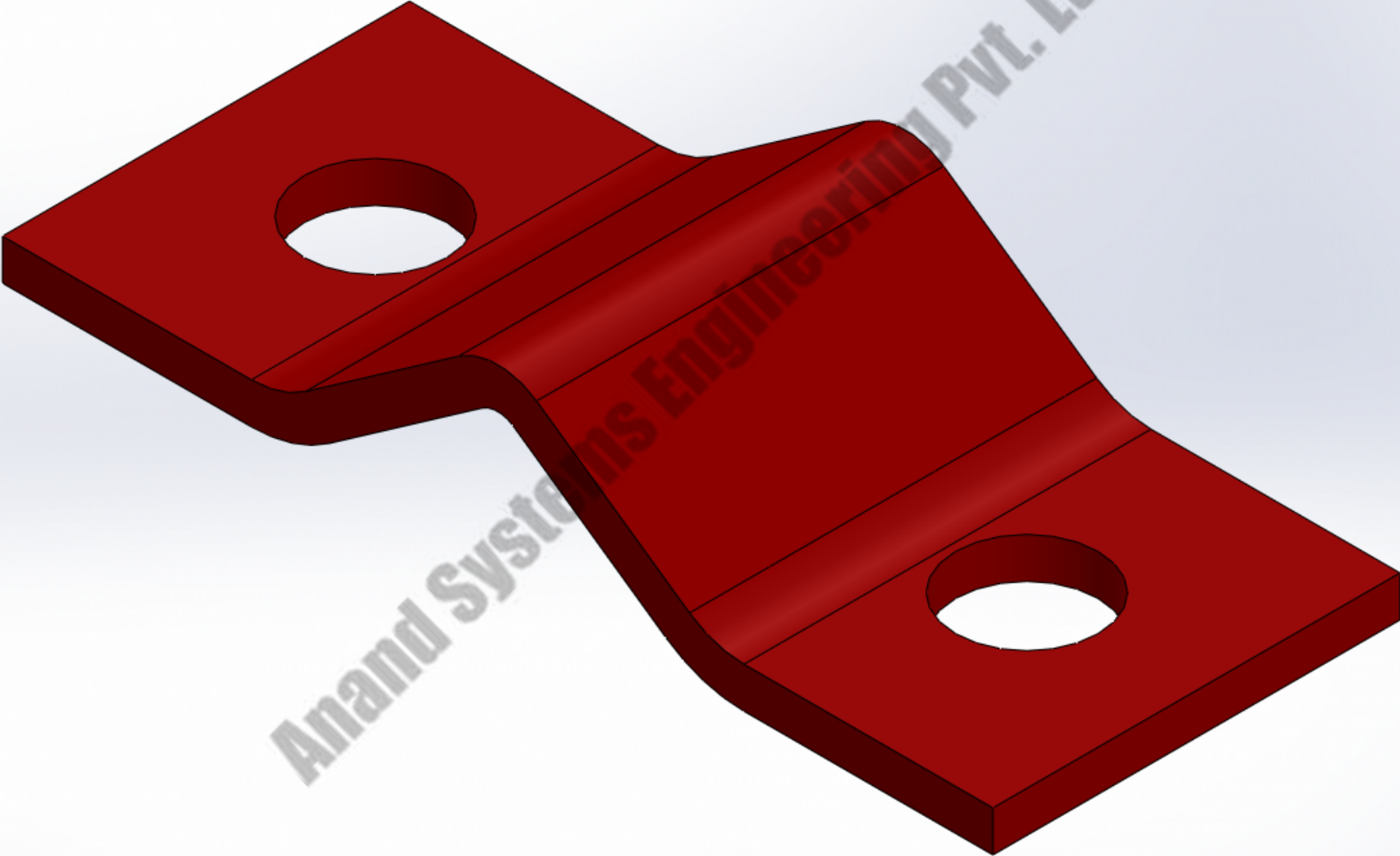

Anand Systems Engineering Pvt. Ltd.

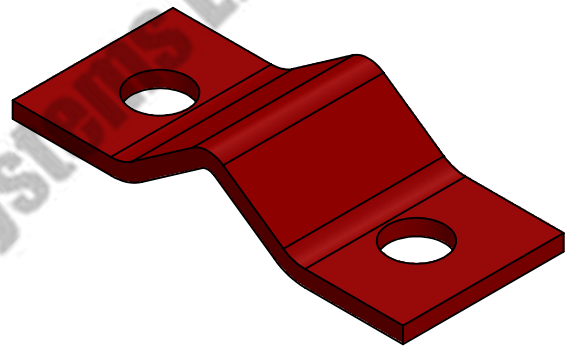
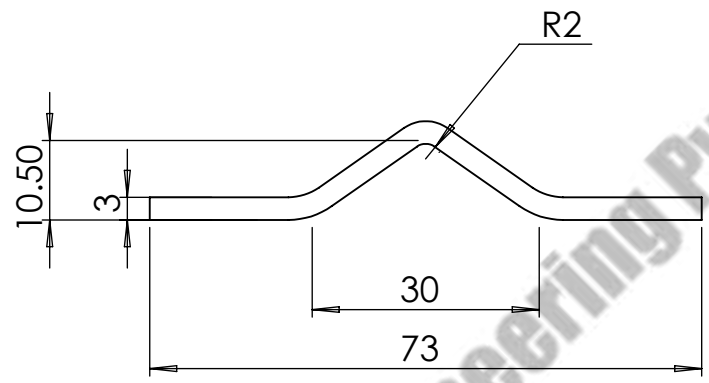
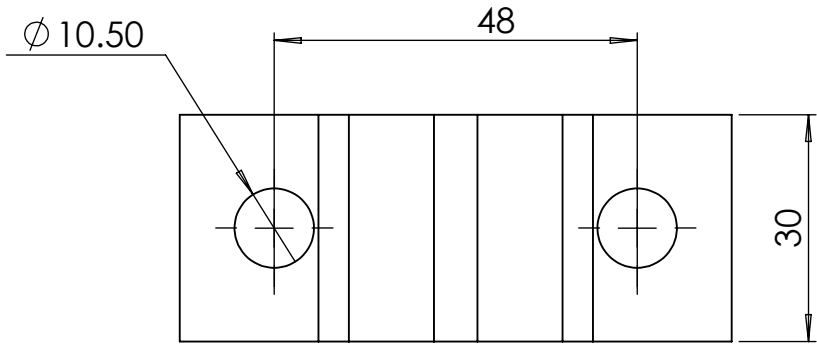

COMPANY NAME:



**ANAND SYSTEM
ENGINEERING PVT LTD**

DO NOT SCALE DRAWING.

REVISION:

TITLE:

**MS MOUNTING
CLAMP CC 250
AMP 1 2D**

Email id: info@anandcontrol.in

CONTACT NO: 9137620579

FINISH:

DWG NO.

DATE:

SIGNATURE:

DRAWN	SAURABH	MATERIAL:	
CHK'D			
APP'D			
MFG		WEIGHT:	

SCALE:

SHEET: 1 OF 1

A

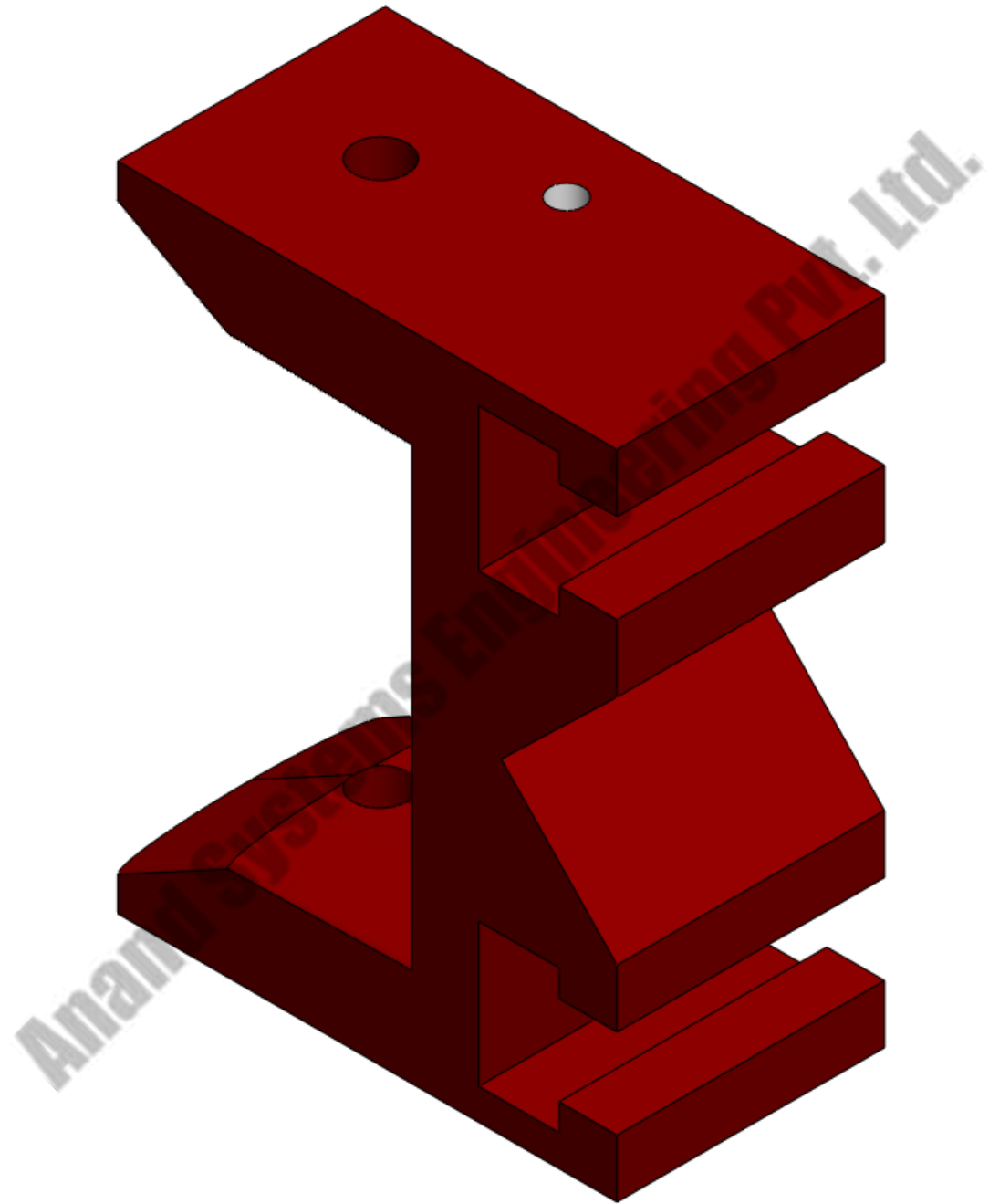

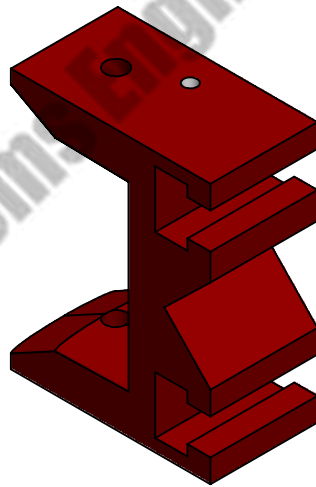
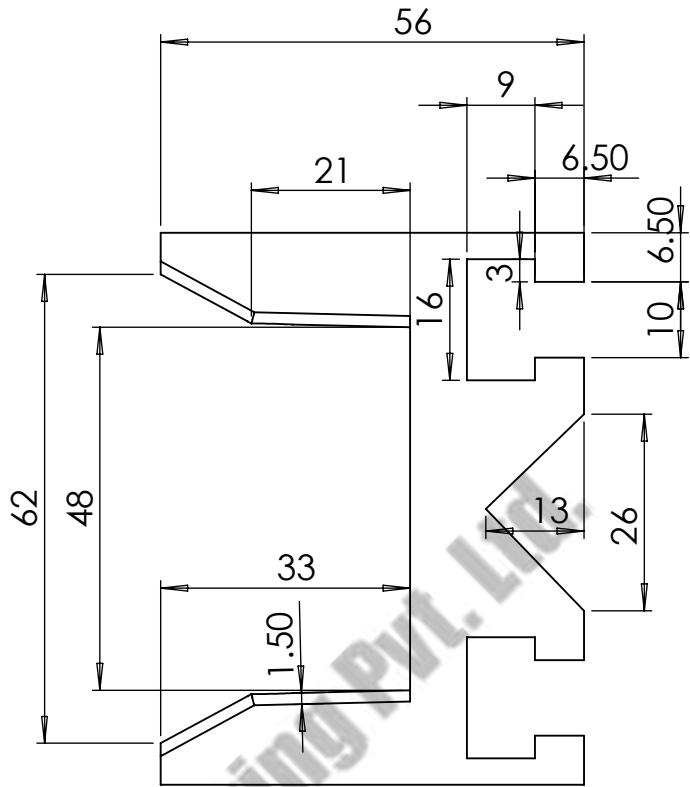
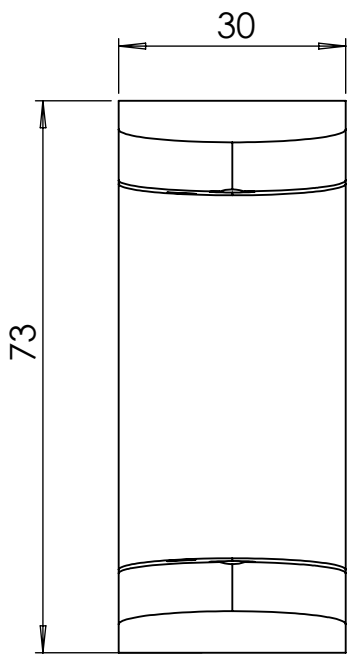

COMPANY NAME:



**ANAND SYSTEM
ENGINEERING PVT LTD**

Email id: info@anandcontrol.in

CONTACT NO: 9137620579

FINISH:

DO NOT SCALE DRAWING.

REVISION:

TITLE:

**LOWER
BRACKET CC
250 AMP 2**

DWG NO.

DATE:

SIGNATURE:

A

SHEET: 1 OF 1

SCALE:

WEIGHT:

MFG

APPV'D

CHK'D

DRAWN

SAURABH

MATERIAL:

WEIGHT:

SCALE:

SHEET: 1 OF 1

WEIGHT:

MFG

APPV'D

CHK'D

DRAWN

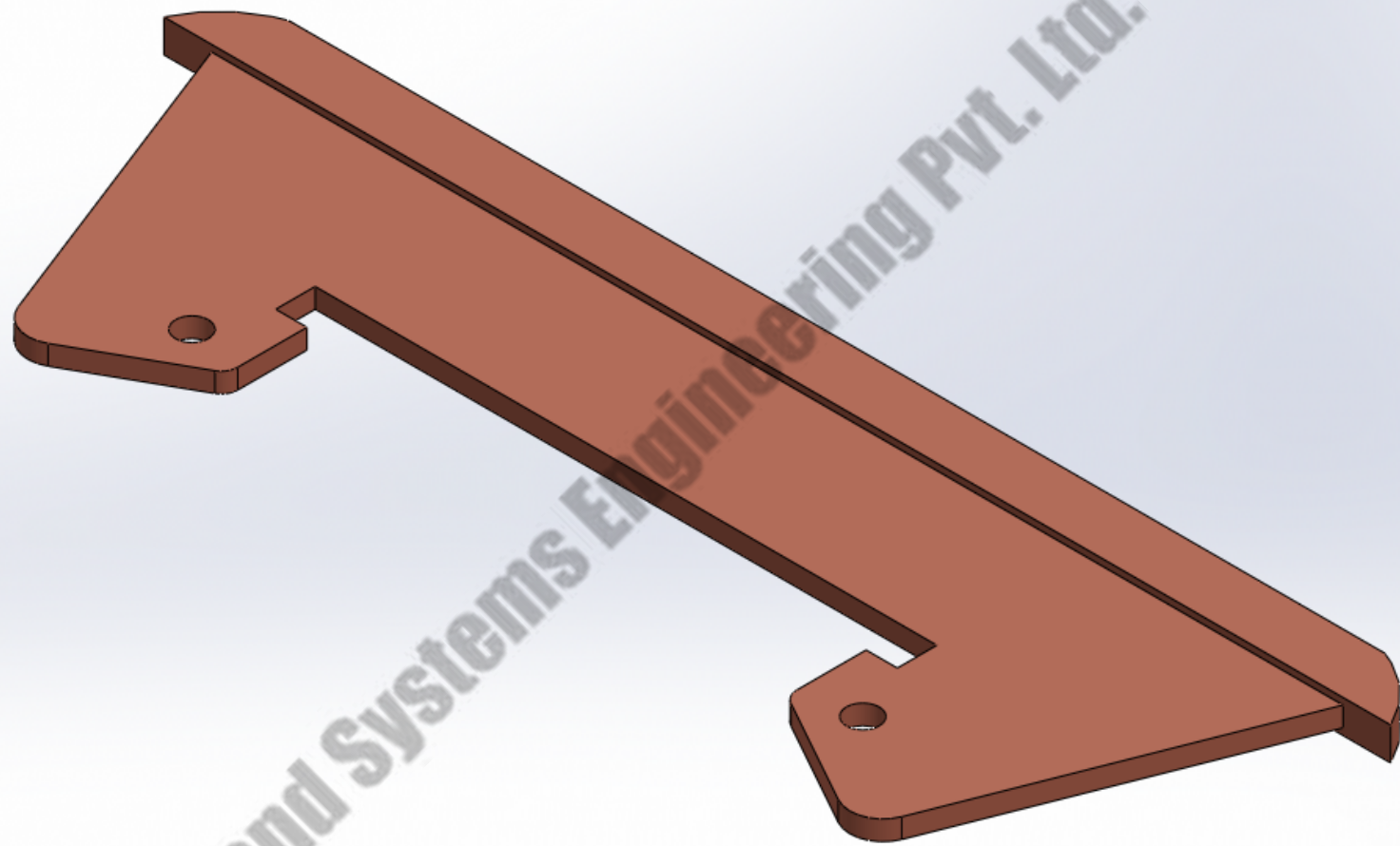

Anand Systems Engineering Pvt. Ltd.

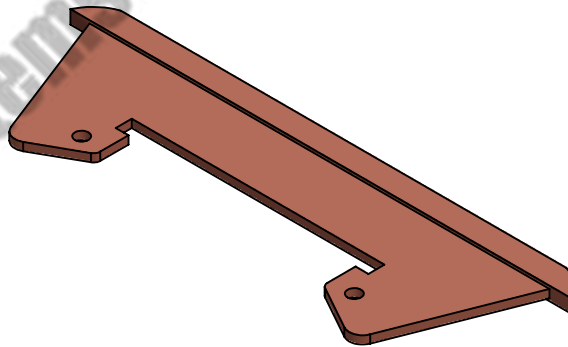
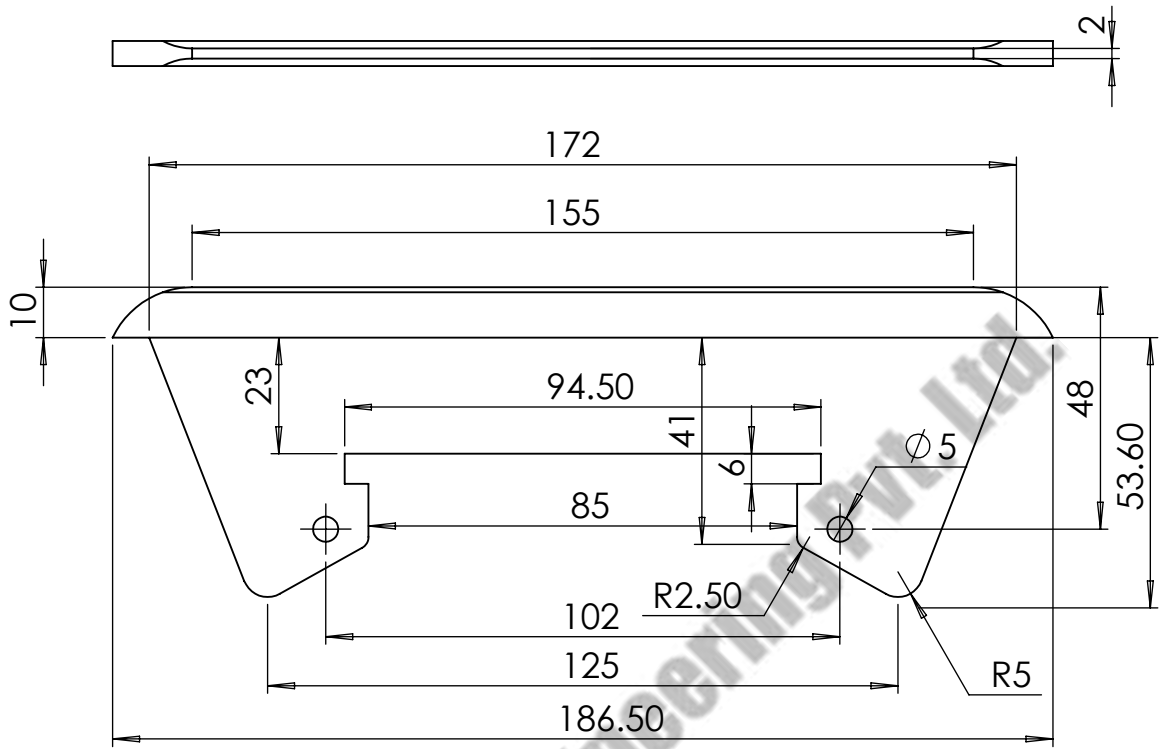

COMPANY NAME:



ANAND SYSTEM
ENGINEERING PVT LTD

DO NOT SCALE DRAWING.

REVISION:

TITLE:

SHOE 250Amp
CC 2D

Email id: info@anandcontrol.in

CONTACT NO: 9137620579

FINISH:

DWG NO.

DATE:

SIGNATURE:

DRAWN	SAURABH
CHK'D	
APP'D	
MFG	

MATERIAL:

WEIGHT:

SCALE:

SHEET: 1 OF 1

A

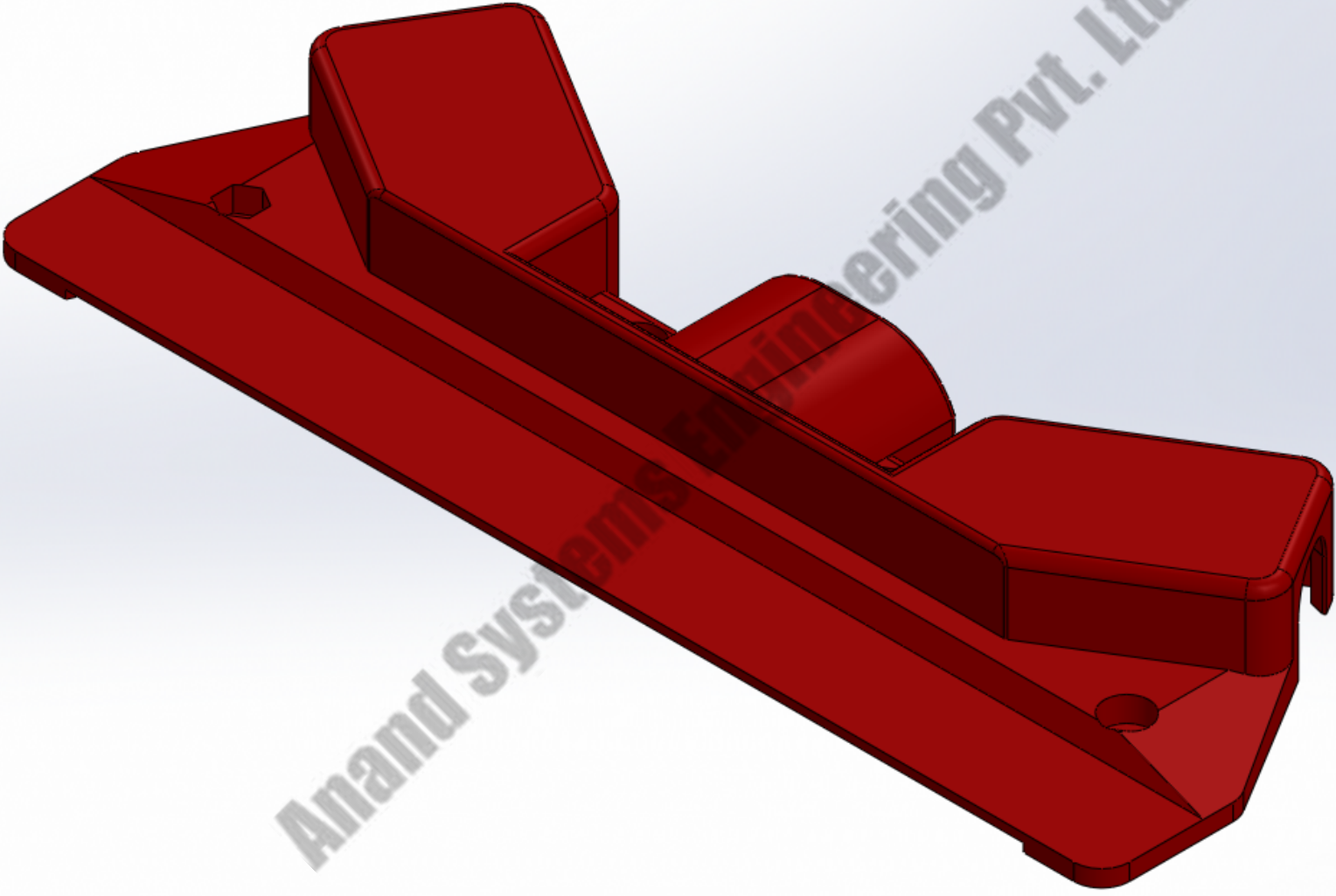

Anand Systems Engineering Pvt. Ltd.

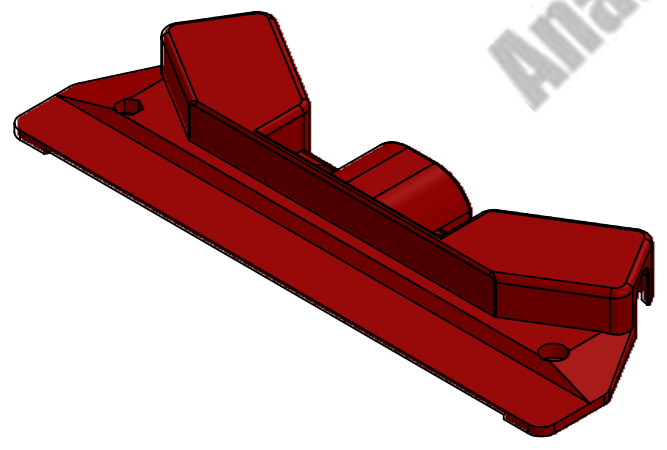
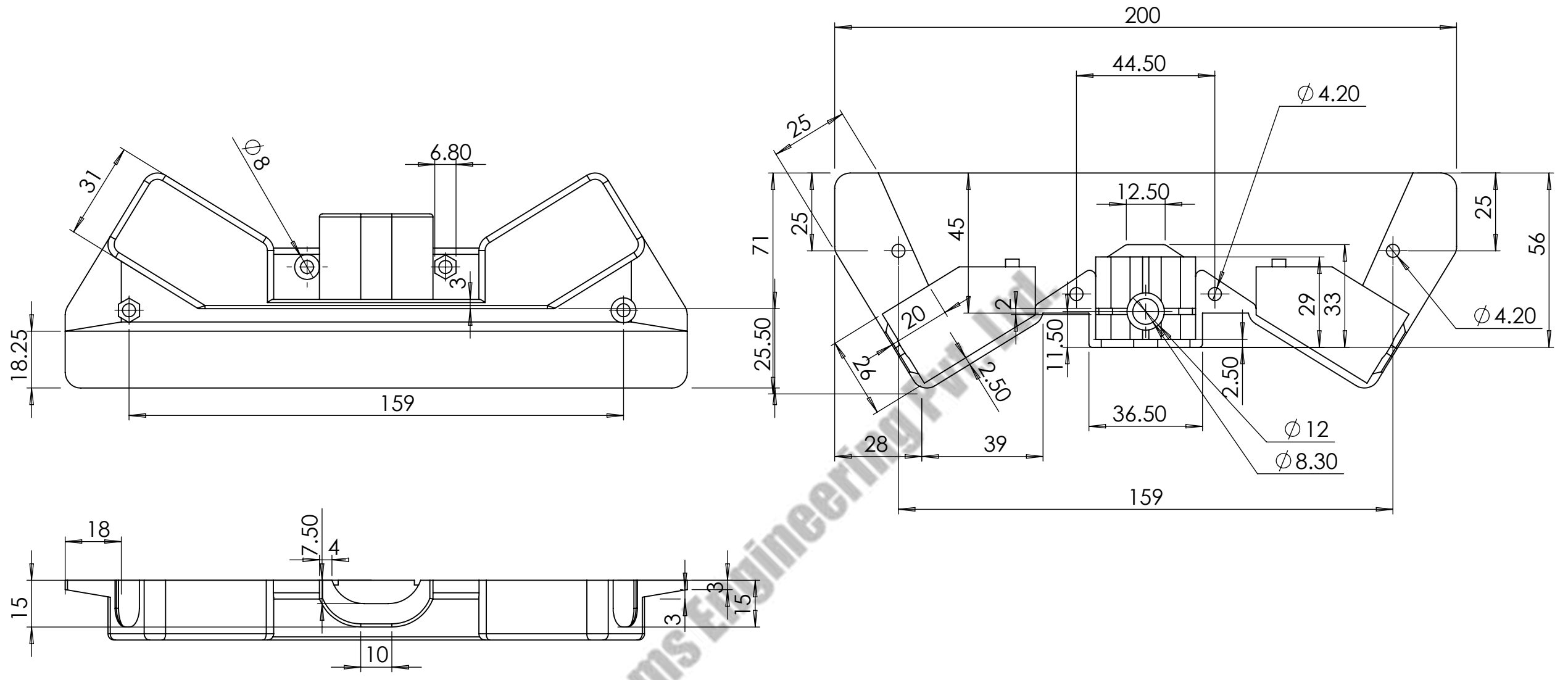

Anand Systems Engineering Pvt Ltd

COMPANY NAME:		DO NOT SCALE DRAWING.		REVISION:	
<p style="text-align: center;">ANAND SYSTEM ENGINEERING PVT LTD</p>		SHOE HOLDER 250AMP 2D			
		Email id: info@anandcontrol.in			
CONTACT NO: 9137620579		FINISH:		DWG NO.	
DRAWN: SAURABH		MATERIAL:		DATE:	
CHK'D:				SIGNATURE:	
APPY'D:				A	
MFG:		WEIGHT:		SCALE:	
				SHEET: 1 OF 1	

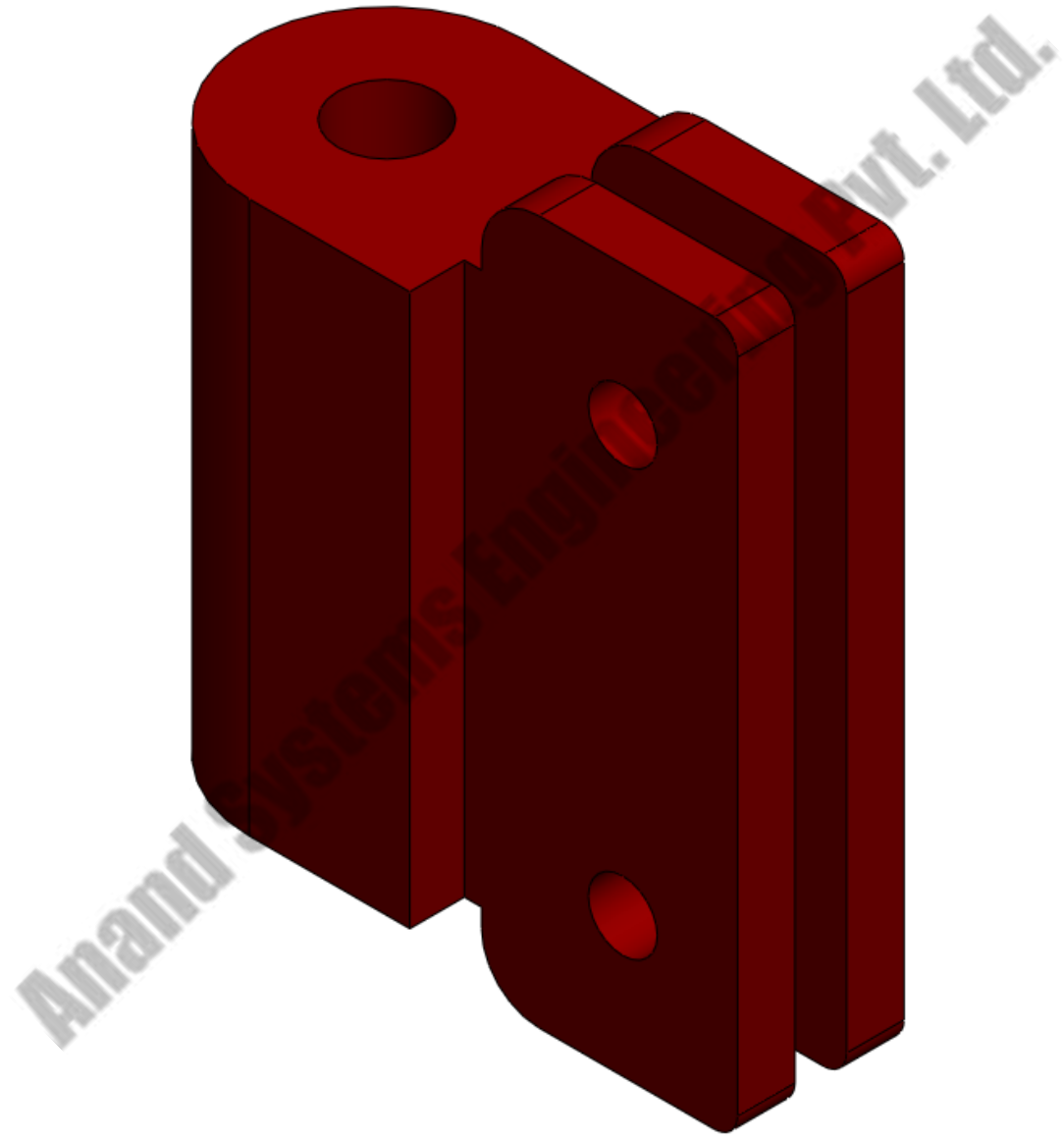

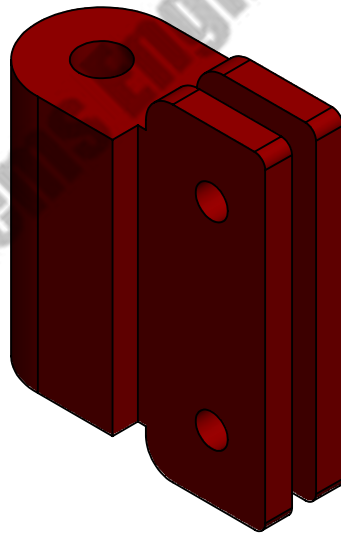
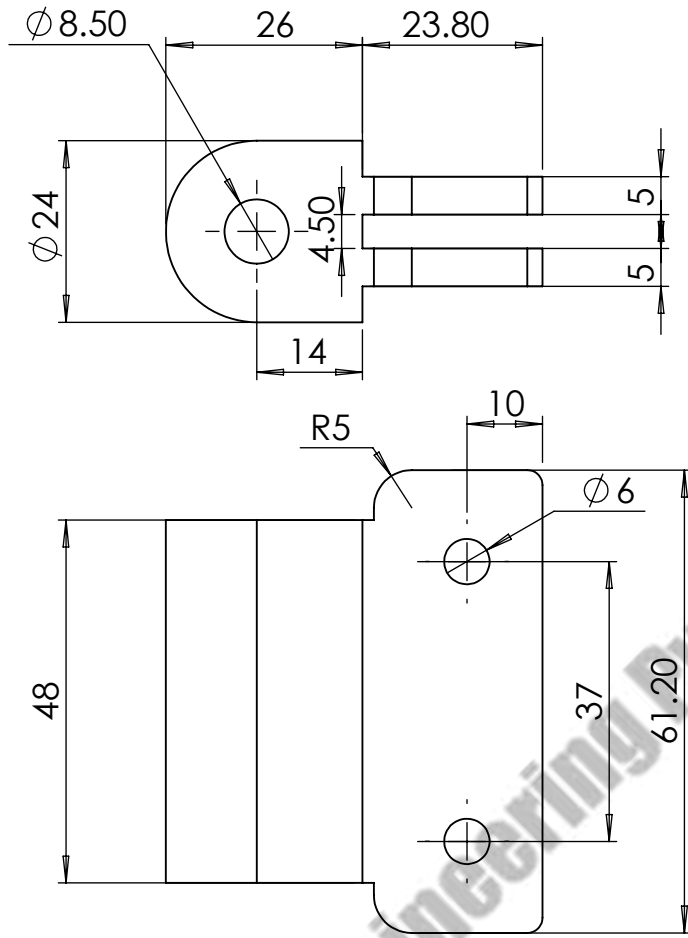

COMPANY NAME:



**ANAND SYSTEM
ENGINEERING PVT LTD**

DO NOT SCALE DRAWING.

REVISION:

TITLE:

**VERTICAL LEVER
CC 250 AMP 2D**

Email id: info@anandcontrol.in

CONTACT NO: 9137620579

FINISH:

DWG NO.

DATE:

SIGNATURE:

DRAWN	SAURABH
CHK'D	
APP'D	
MFG	

MATERIAL:

WEIGHT:

SCALE:

SHEET: 1 OF 1

A

EXPANSION JOINT CLAMP

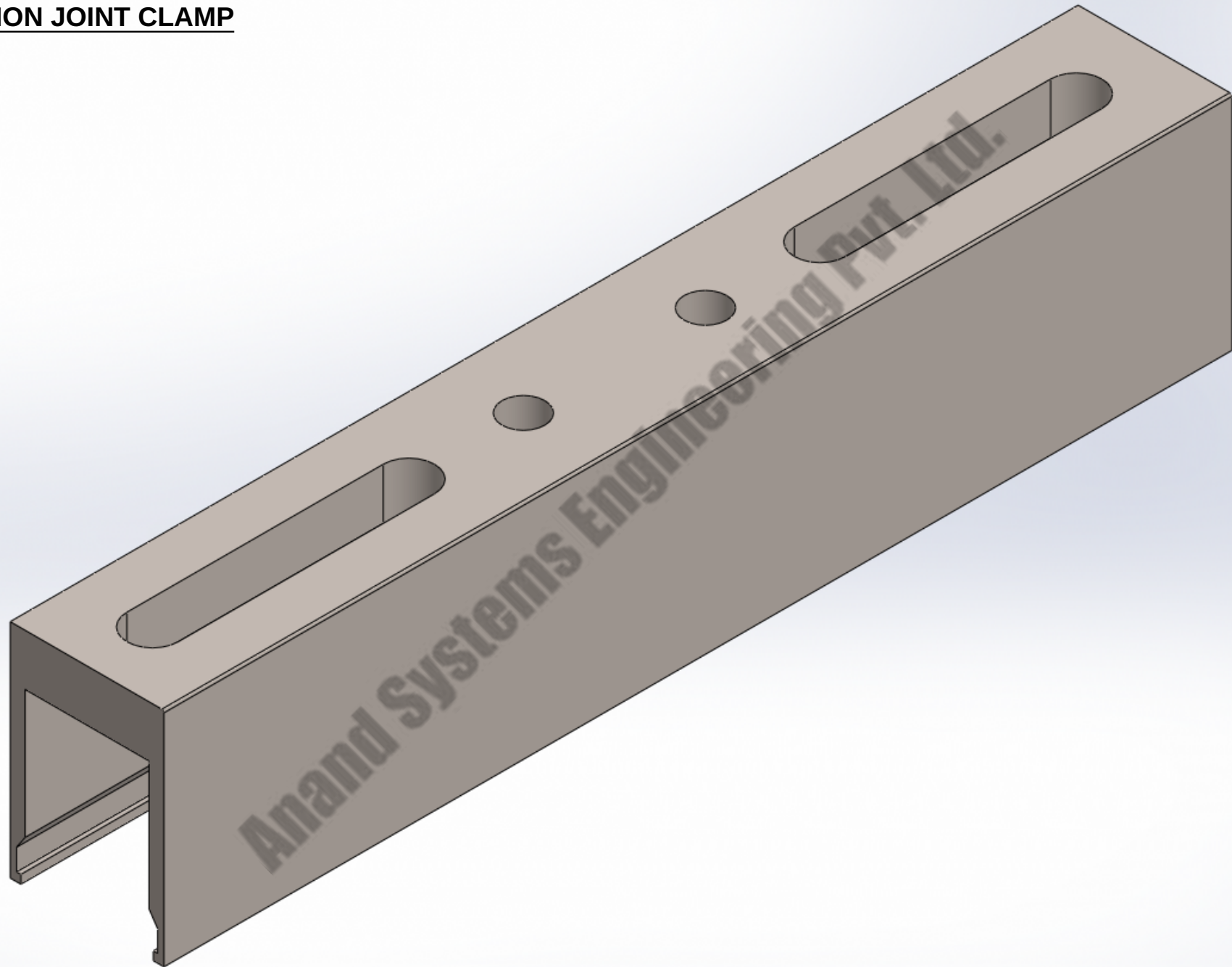

GRUMET

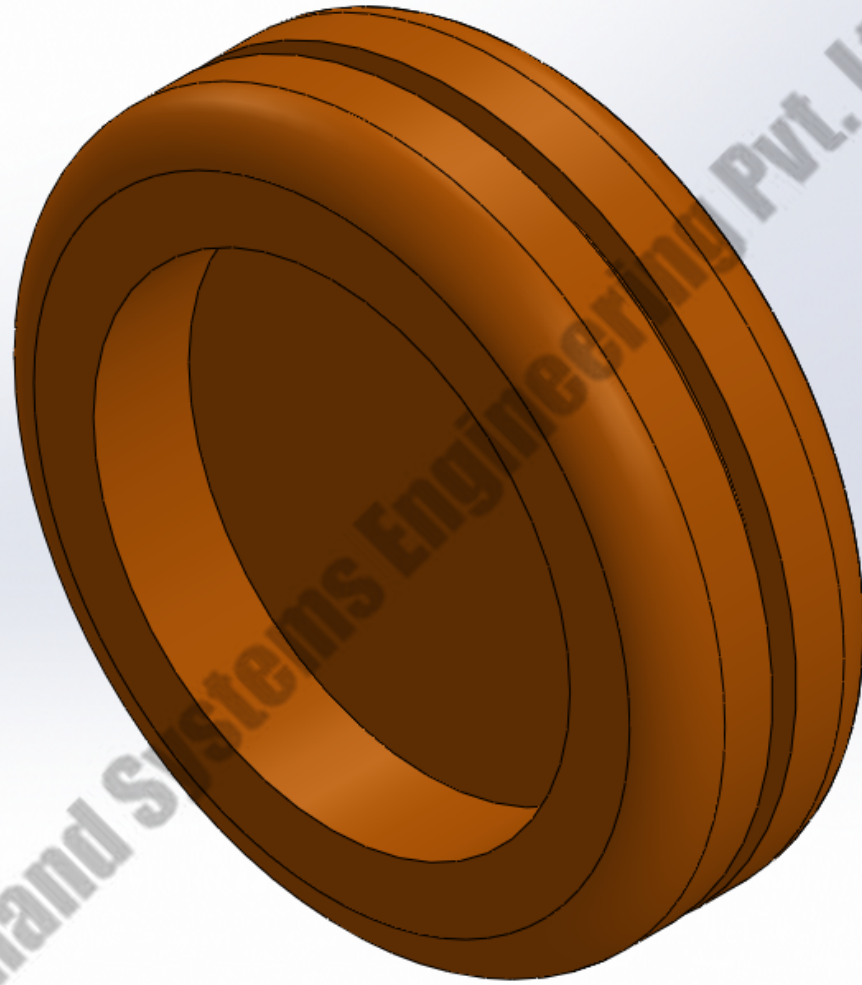

Anand Systems Engineering Pvt. Ltd.

M5 BOLT

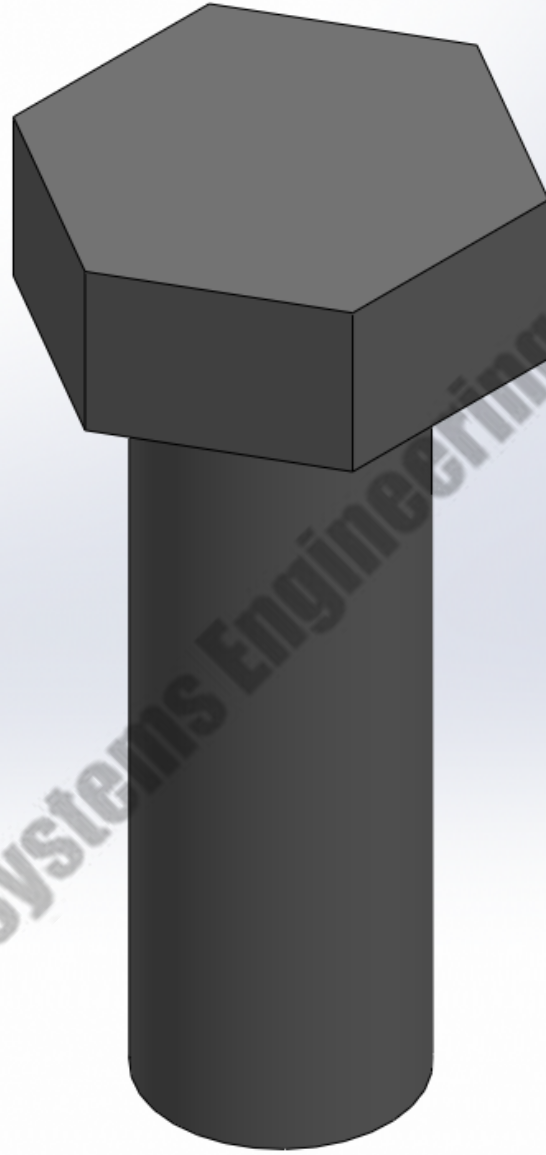

E-CIRCLIP

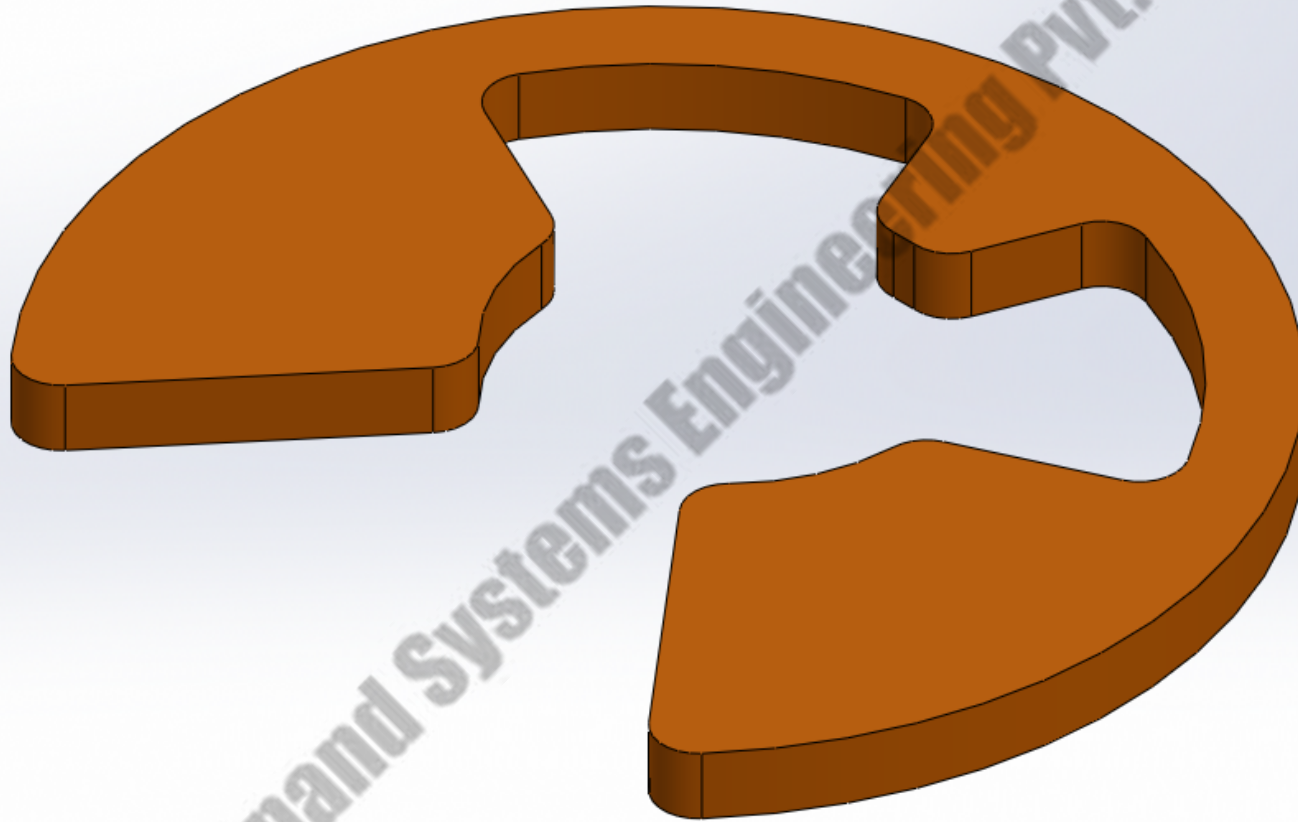

M10 BOLT



Anand Systems Engineering Pvt. Ltd.

JOINT CLAMP PLATE
WITH ATTACHED BOLT

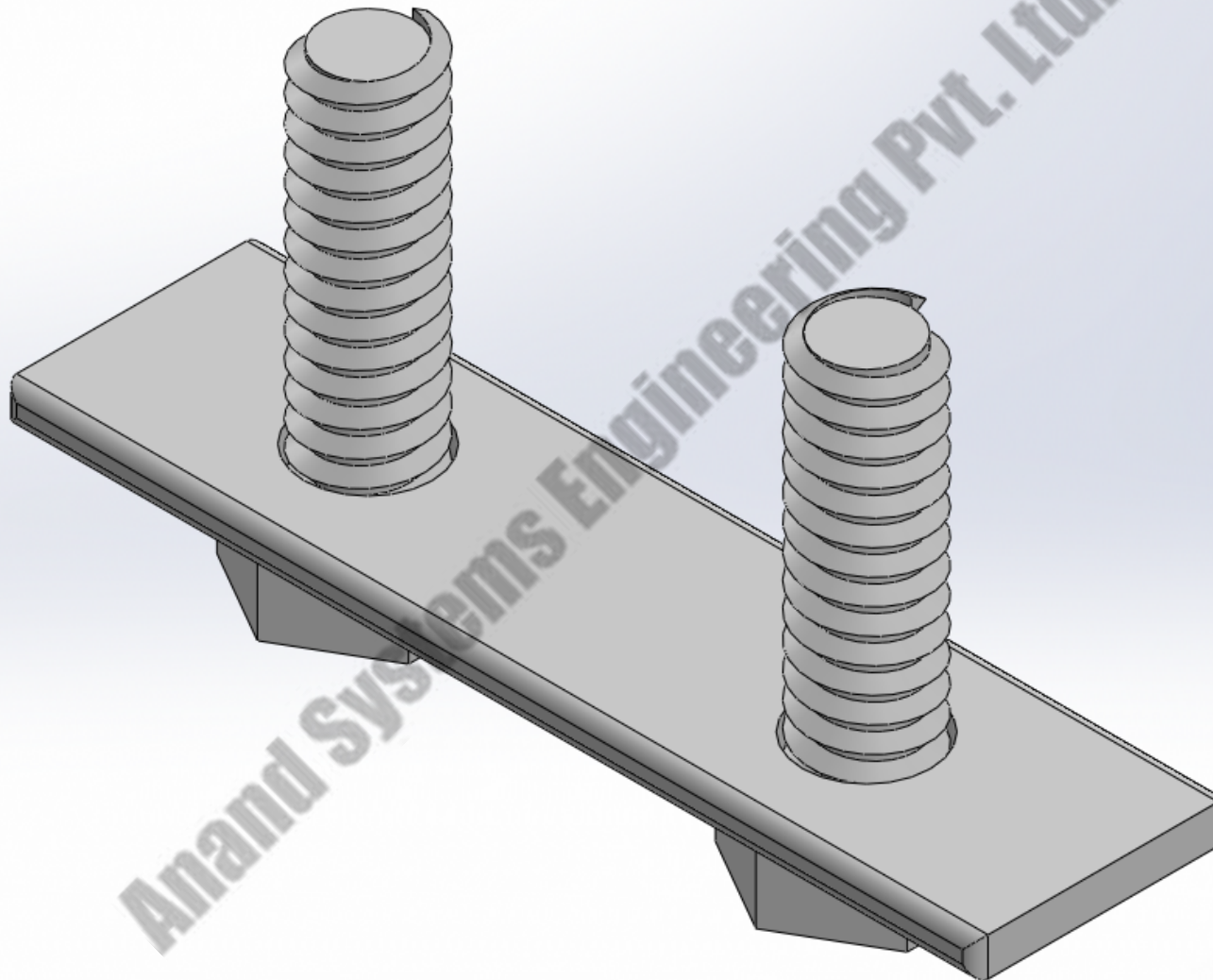

M5 NUT

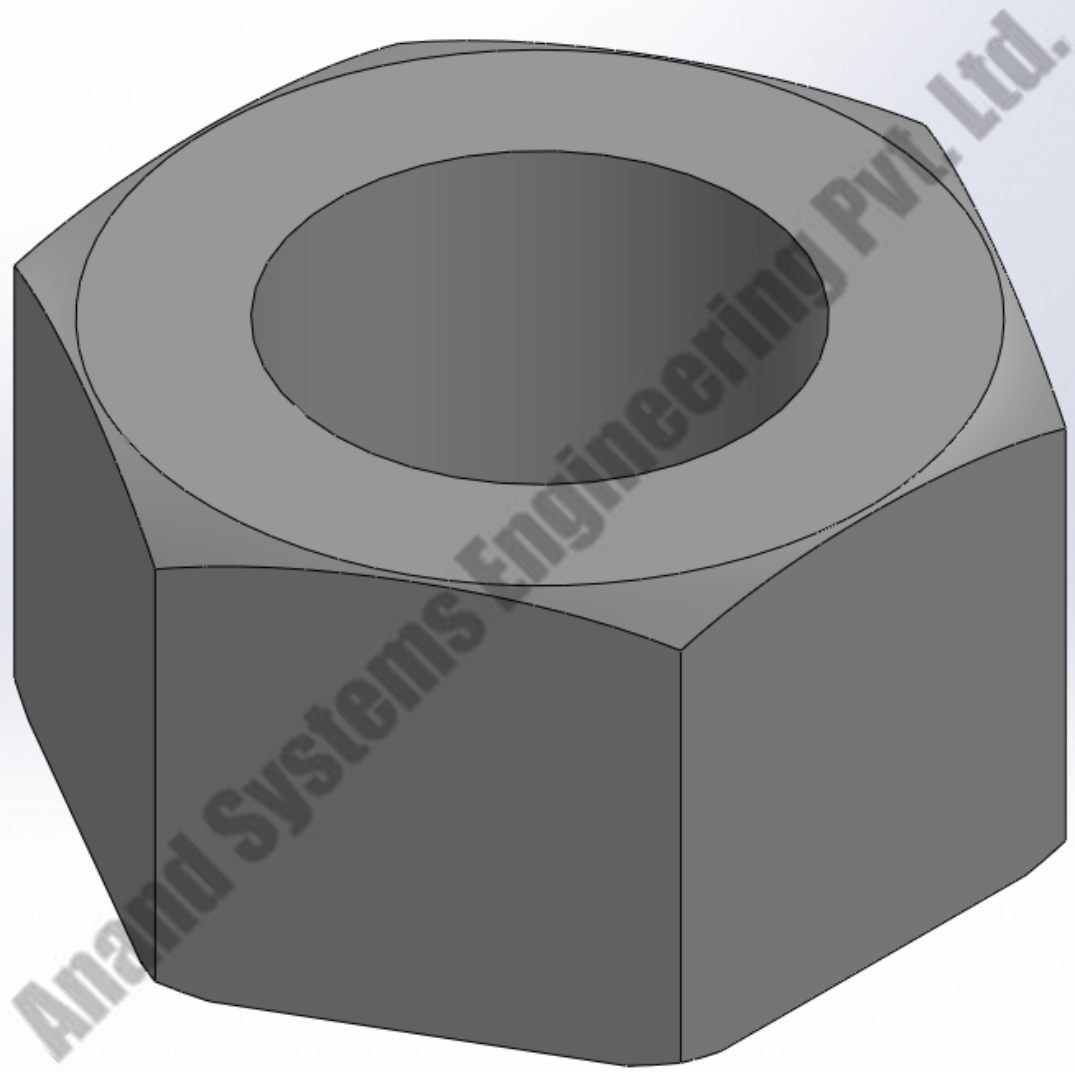

M10 NUT

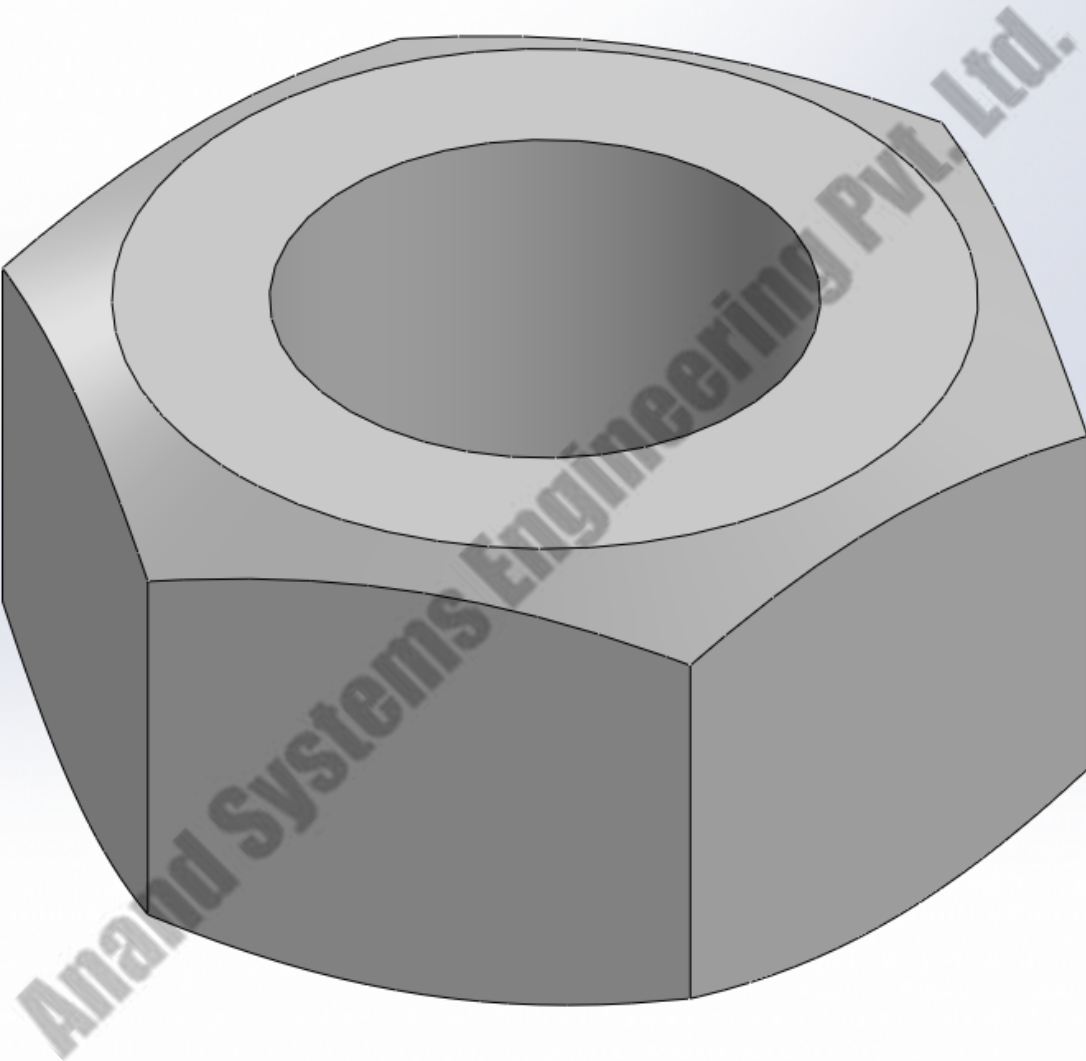

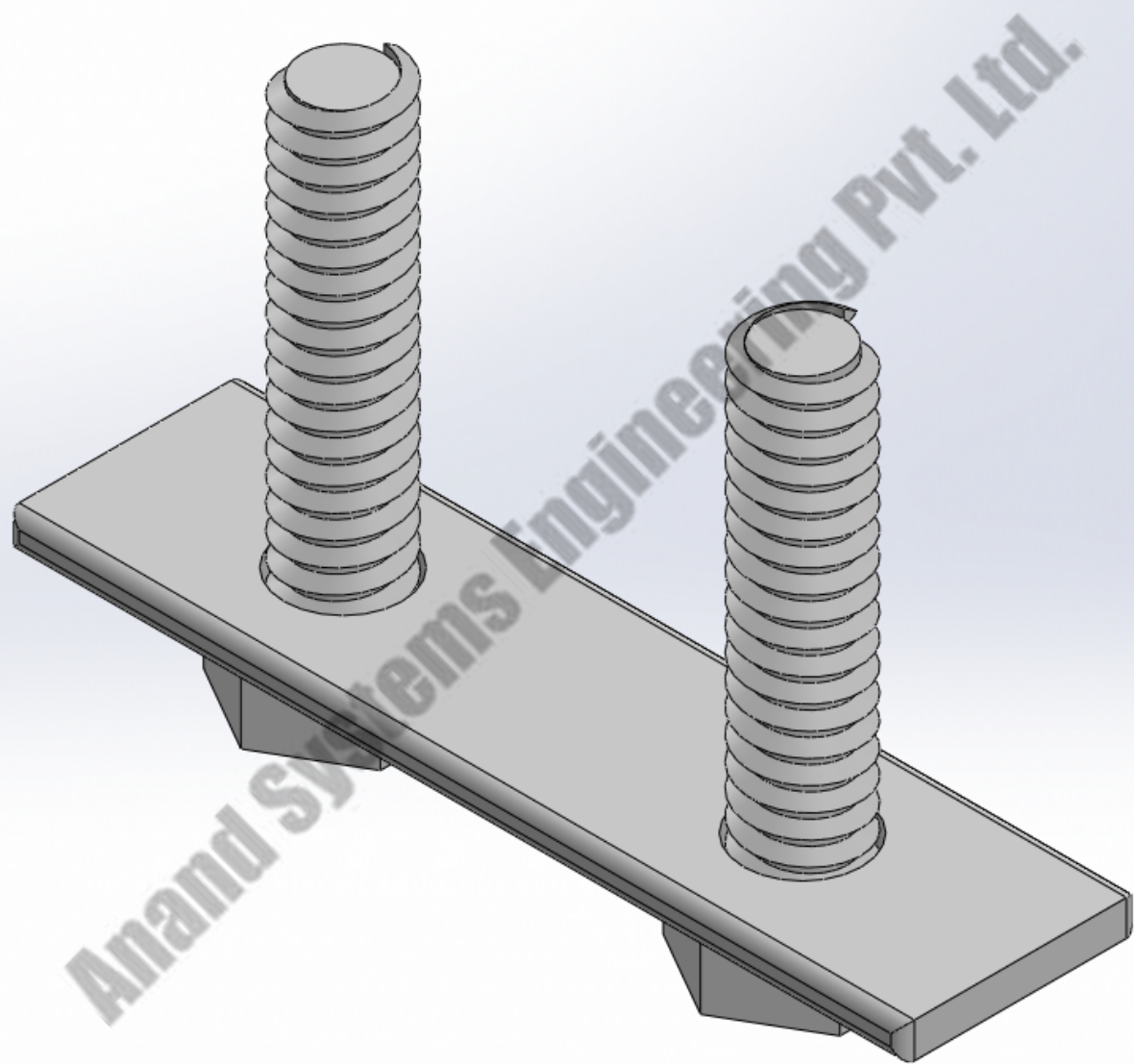

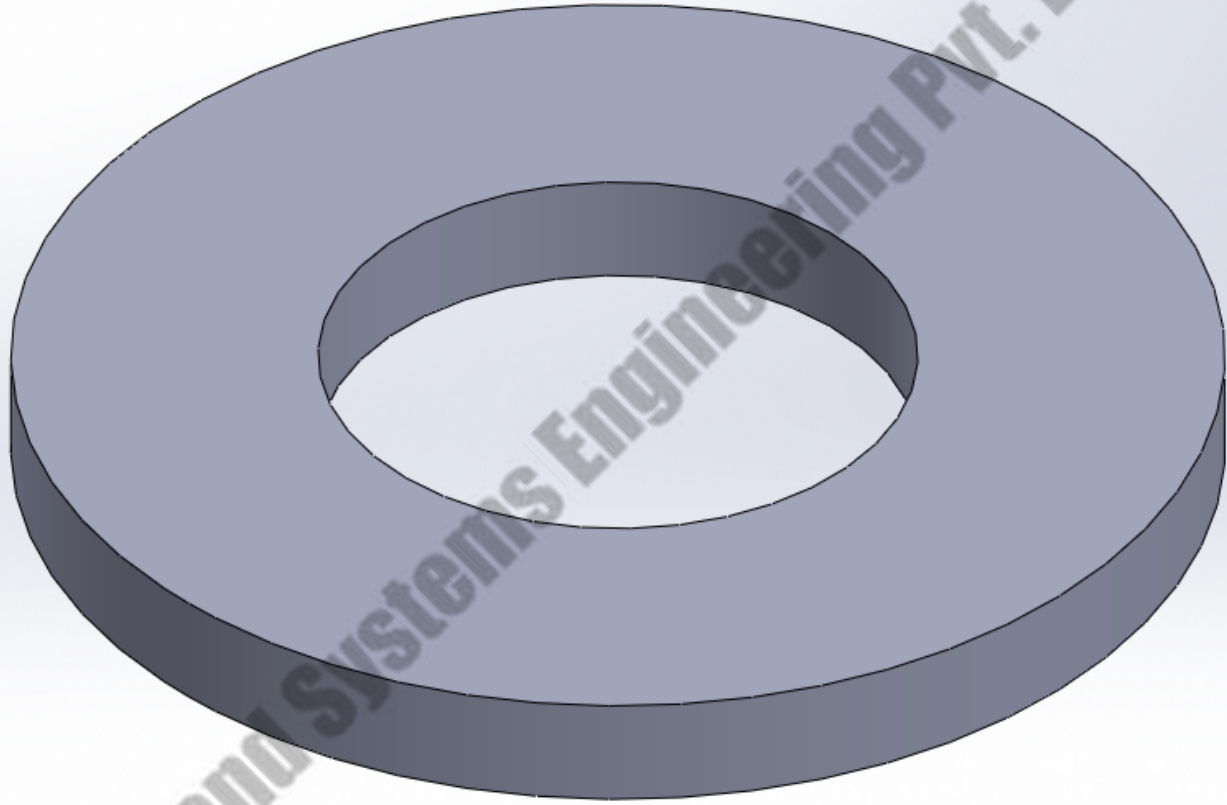

NYLON INSERT
NUT M10

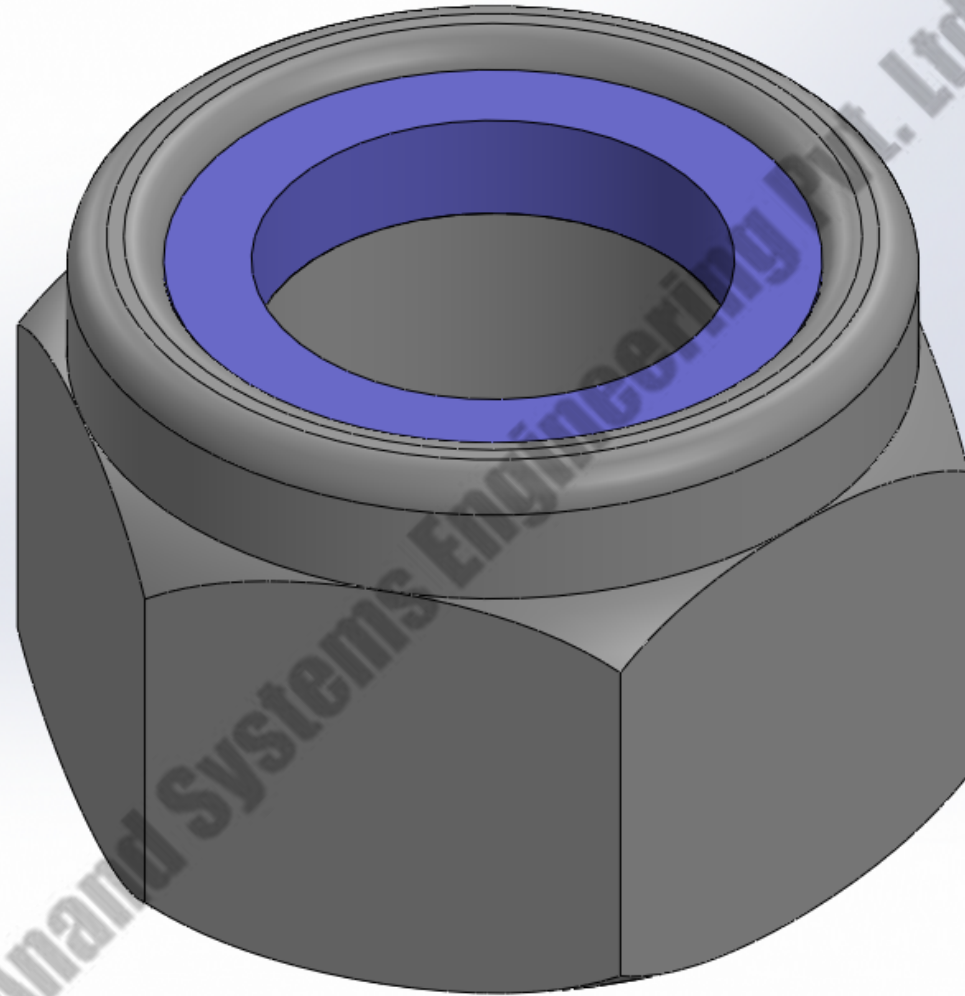

PIN 16X70

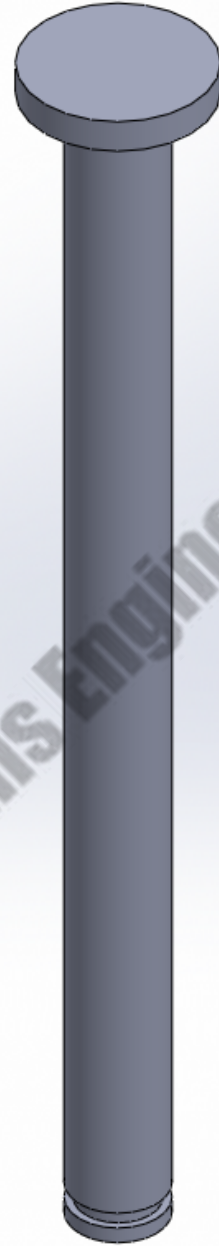

Anand Systems Engineering Pvt. Ltd.

PLAIN WASHER M5

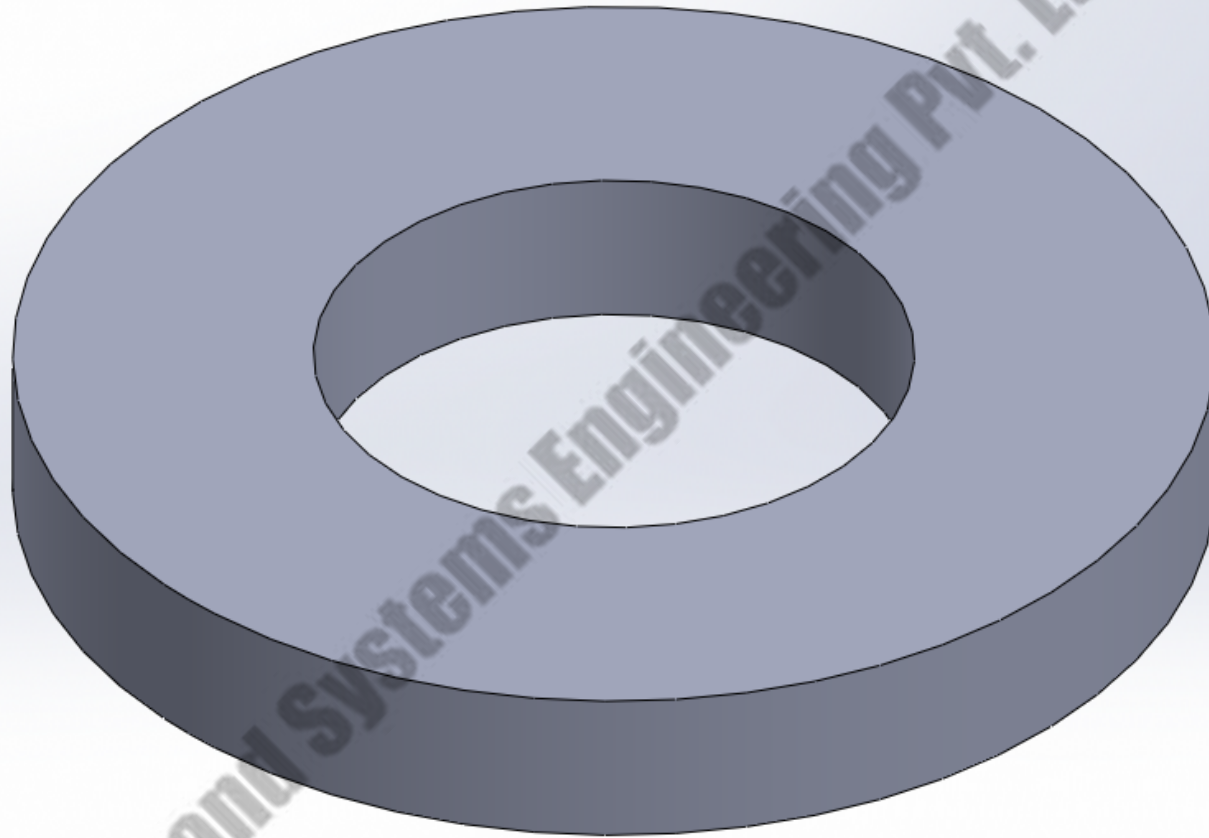

Anand Systems Engineering Pvt. Ltd.

PLAIN WASHER M10

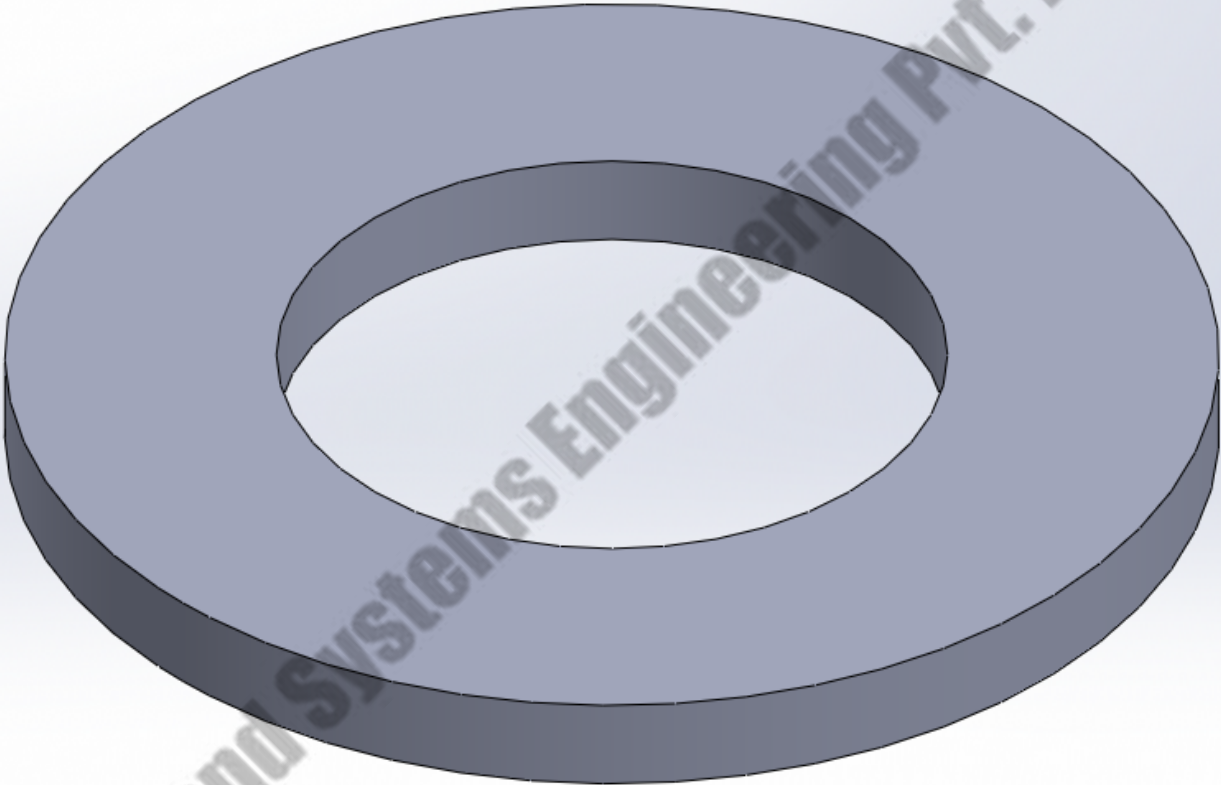

Anand Systems Engineering Pvt. Ltd.

PLAIN WASHER
M10X25

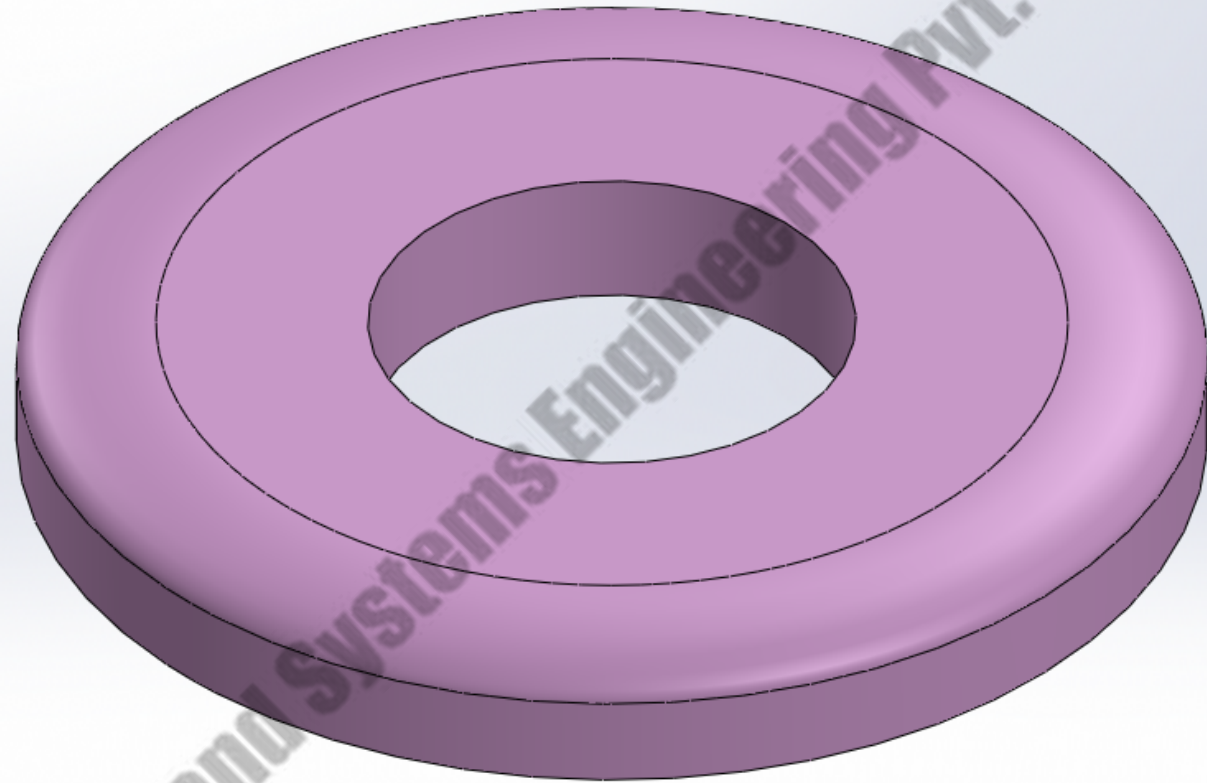

ANCHOR CLAMP BOLT
SELF THREADED

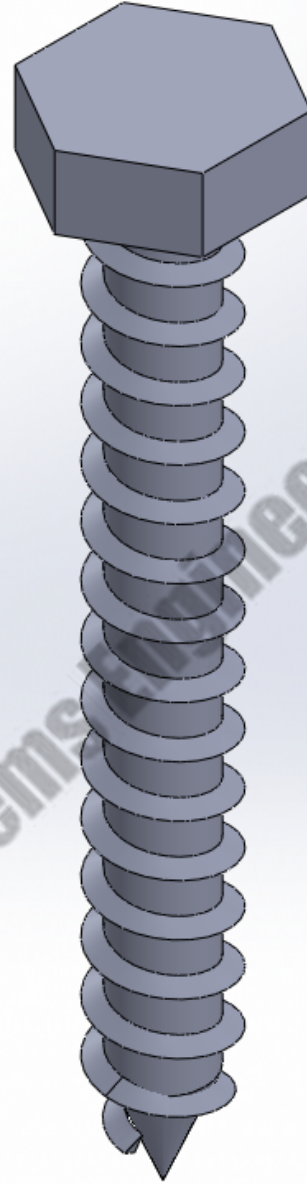

Anand Systems Engineering Pvt. Ltd.

SPACER PIN

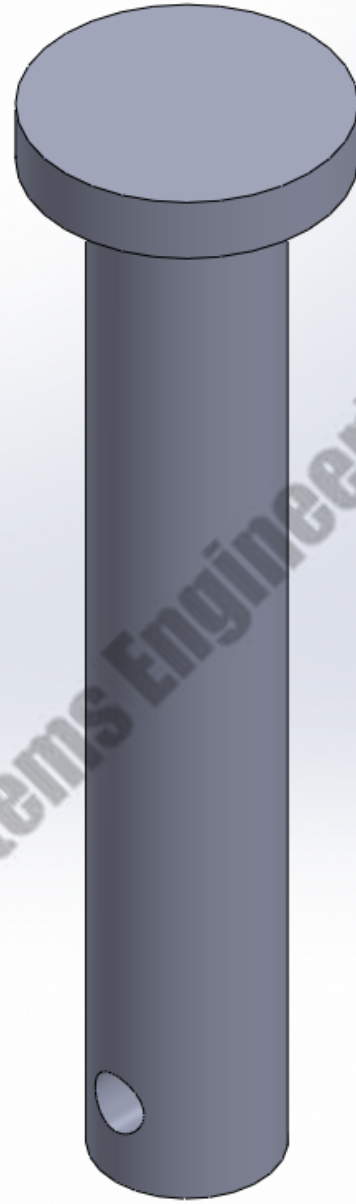

Anand Systems Engineering Pvt. Ltd.

TENSION PIN



Anand Systems Engineering Pvt. Ltd.

M8 SPRING WASHER



SQUARE
HEADED
BOLT

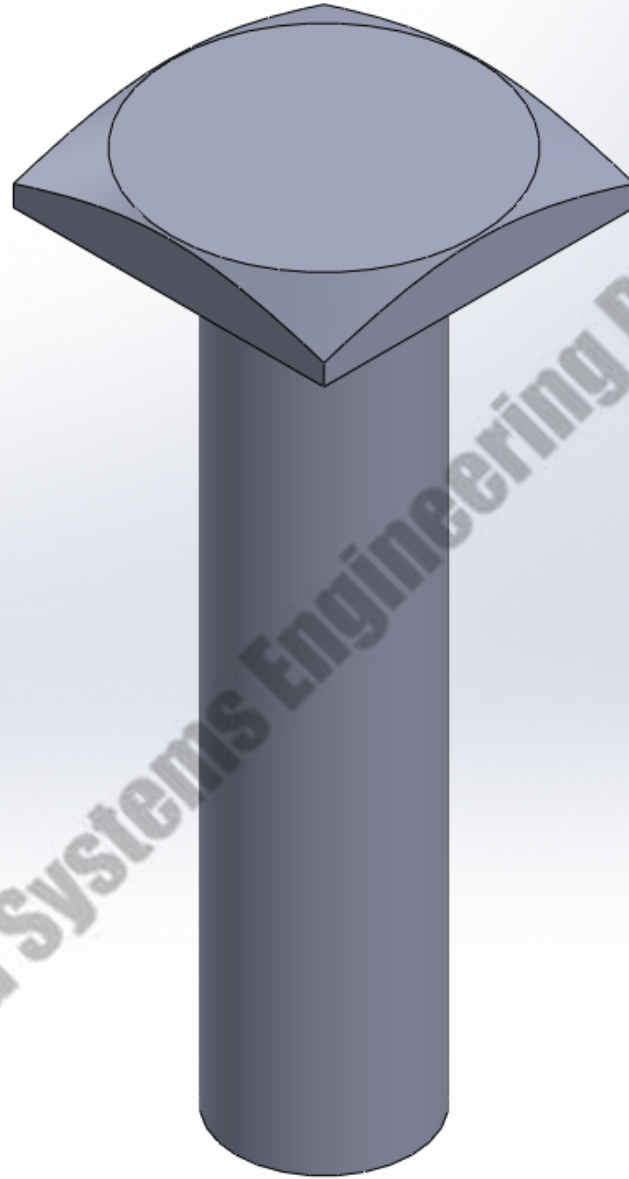

Anand Systems Engineering Pvt. Ltd.

VERTICAL PIN



Anand Systems Engineering Pvt. Ltd.

DOWEL PIN



Anand Systems Engineering Pvt. Ltd.

WEB BRACKET

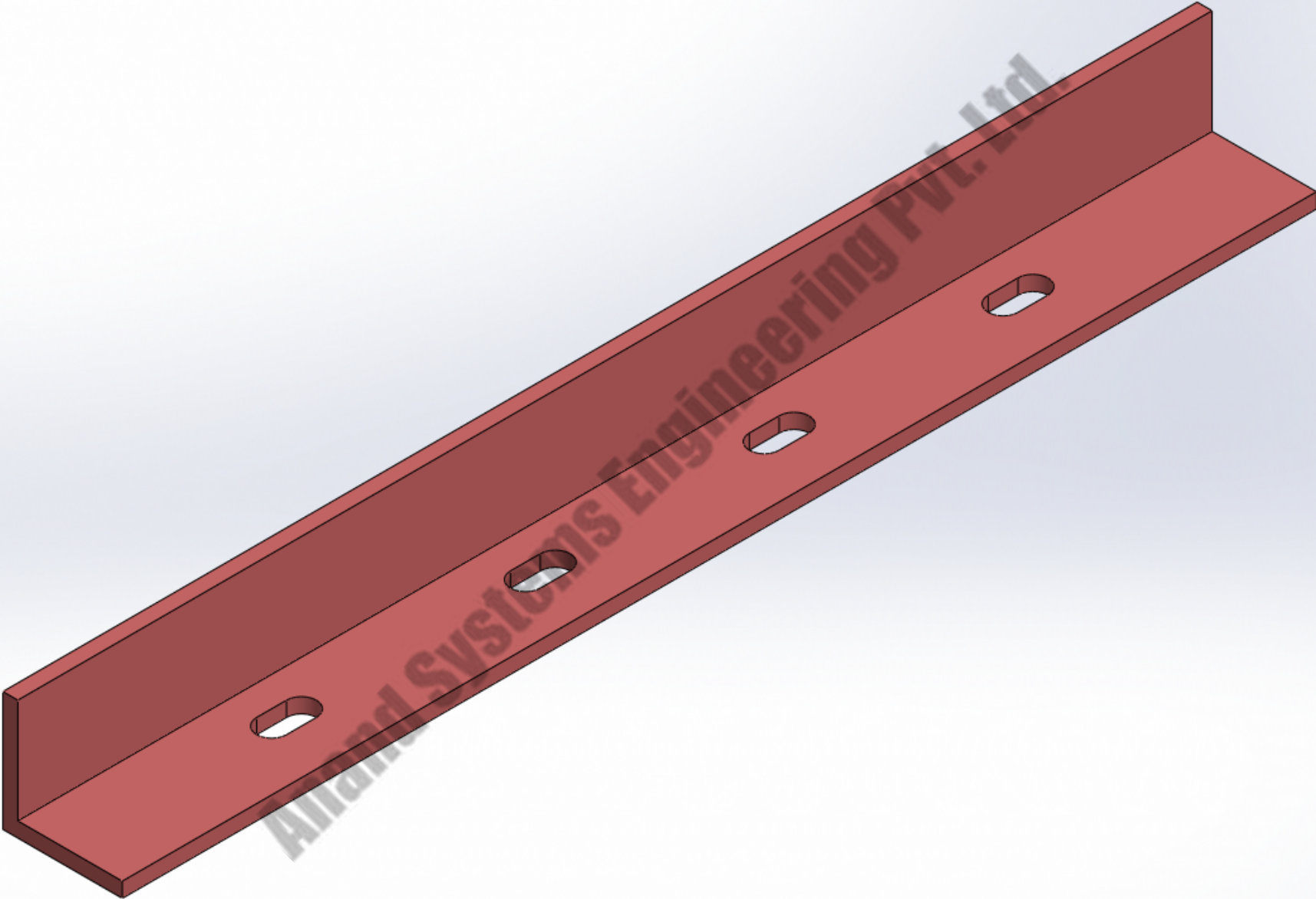

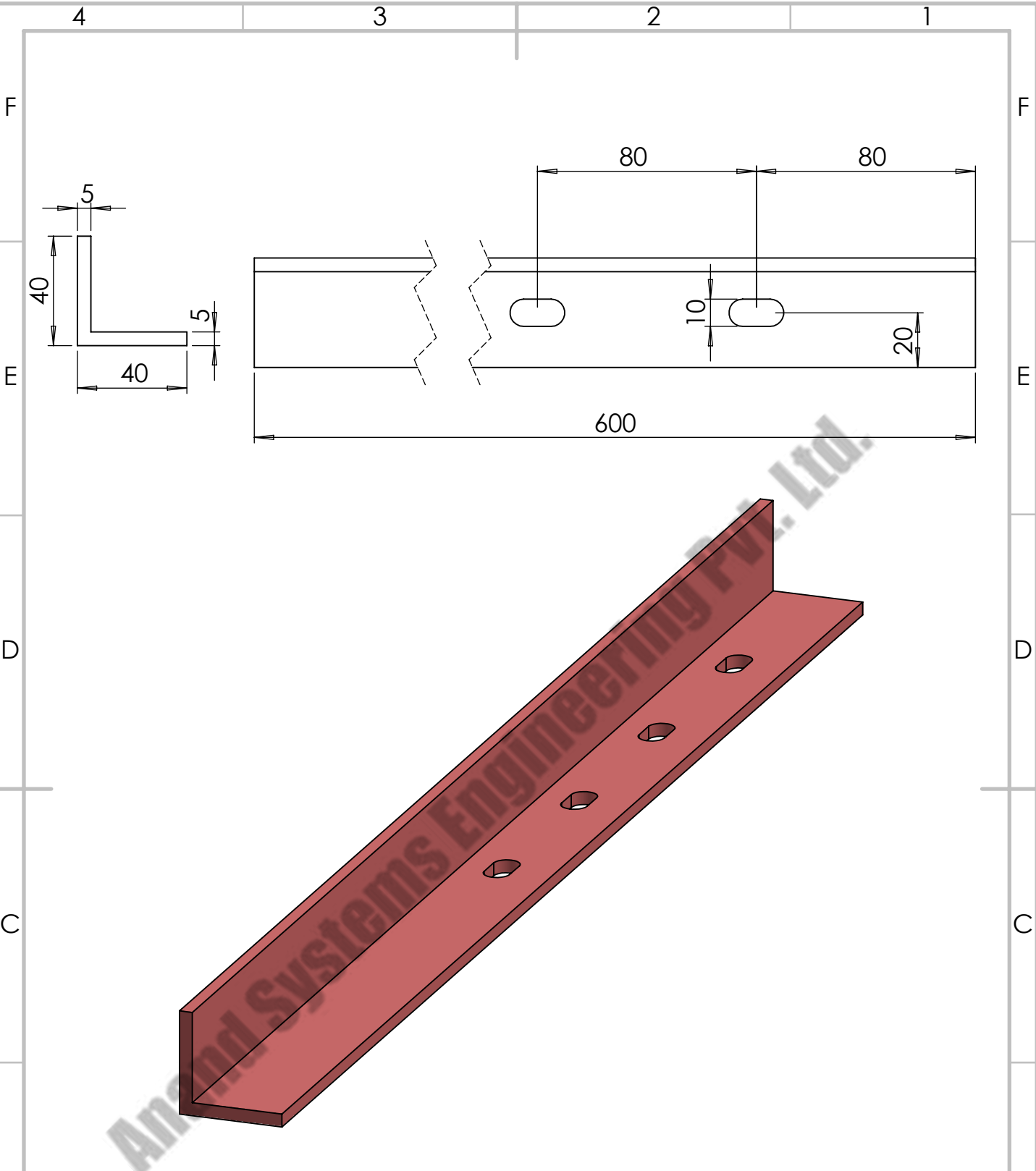

COMPANY NAME:		DO NOT SCALE DRAWING.		REVISION:	
		ANAND SYSTEM ENGINEERING PVT LTD		TITLE: WEB BRACKET 600 V-TYPE 2D	
Email id: info@anandcontrol.in		FINISH:		DWG NO.	
CONTACT NO: 9137620579				DATE:	
DRAWN: SAURABH		MATERIAL: M.S.		SIGNATURE:	
CHK'D:				A	
APP'D:					
MFG:		WEIGHT:		SCALE:	
				SHEET: 1 OF 1	

